

# *AIT Drive*

---

User's Guide

*AIT-3 TAPE DRIVE*  
***SDX-700V Series***

This document contains proprietary information which is protected by copyright.

All rights reserved. No part of this document may be photocopied, reproduced or translated to another language without prior written consent of Sony.

The information contained in this document is subject to change without notice.

**SONY MAKES NO WARRANTY OF ANY KIND WITH REGARD TO THIS DOCUMENT.**

Sony shall not be liable for errors contained herein, indirect, special, incidental or consequential damages in connection with the furnishing, performance or use of this document.

Your AIT TAPE DRIVE is assigned a Model No. ATDNA3 for regulatory compliance certifications.

The number is indicated on the model number label on your drive along with the rated voltage and current.

## **VORSICHT**

Diese Ausrüstung erfüllt die Europäischen EMC-Bestimmungen für die Verwendung in folgender / folgenden Umgebung(en):

- Wohngegenden
- Gewerbegebiete
- Leichtindustrialgebiete

(Diese Ausrüstung erfüllt die Bestimmungen der Norm EN55022, Klasse B.)

### 사용자 안내문

이 기기는 가정용으로 전자파 적합등록을 한 기기로서 주거지역에서는 물론 모든 지역에서 사용할 수 있습니다.

기기의 명칭 (모델명) : ATDNA3  
인증받은자의 상호 : SONY KOREA Corp.  
제조년월일 : 별도표시  
제조사/제조국가 : SONY CORP./일본,중국

## IMPORTANT SAFEGUARDS

For your protection, please read these safety instructions completely before operating the appliance, and keep this manual for future reference.

Carefully observe all warnings, precautions and instructions on the appliance, or the one described in the operating instructions and adhere to them.

## USE

**Power Sources** – This unit should be operated only from the type of power source indicated on the marking label. If you are not sure of the type of electrical power, consult your dealer or local power company.

**For the unit with a three-wire grounding type ac plug:**

If you are unable to insert the plug into the outlet, contact your electrician to have a suitable plug installed. Do not defeat the safety purpose of the grounding plug.

**AC Power cord: (for AC mains operating unit only)**

The AC power cord should have appropriate safety approvals or marking for the country in which the equipment will be used. Consult your dealer or local power company.

**Cleaning** – Unplug the unit from the wall outlet before cleaning or polishing it. Do not use liquid cleaners or aerosol cleaners. Use a cloth lightly dampened with water for cleaning the exterior of the unit.

**Object and Liquid Entry** – Never push objects of any kind into the unit through openings as they may touch dangerous voltage points or short out parts that could result in a fire or electric shock. Never spill liquid of any kind on the unit.

## INSTALLATION

**Water and Moisture** – Do not use power-line operated units near water - for example, near a bathtub, washbowl, kitchen sink, or laundry tub, in a wet basement, or near a swimming pool, etc.

**Power-Cord Protection** – Route the power cord so that it is not likely to be walked on or pinched by items placed upon or against them, paying particular attention to the plugs, receptacles, and the point where the cord exits from the appliance.

**Accessories** – Do not place the unit on an unstable cart, stand, tripod, bracket, or table. The unit may fall, causing serious injury to a child or an adult, and serious damage to the unit. Use only a cart stand tripod, bracket, or table recommended by the manufacturer.

**Ventilation** – The slots and openings in the cabinet are provided for necessary ventilation. To ensure reliable operation of the unit, and to protect it from overheating, these slots and openings must never be blocked or covered.

- Never cover the slots and openings with a cloth or other materials.
- Never block the slots and openings by placing the unit on a bed, sofa, rug or other similar surface.
- Never place the unit in a confined space, such as a bookcase, or built-in cabinet, unless proper ventilation is provided.

## SERVICE

**Damage Requiring Service** – Unplug the unit from the wall outlet and refer servicing to qualified service personnel under the following conditions:

- When the power cord or plug is damaged or frayed.
- If liquid has been spilled or objects have fallen into the unit.
- If the unit has been exposed to rain or water.
- If the unit has been subject to excessive shock by being dropped, or the cabinet has been damaged.
- If the unit does not operate normally when following the operating instructions. Adjust only those controls that are specified in the operating instructions. Improper adjustment of other controls may result in damage and will often require extensive work by a qualified technician to restore the unit to normal operation.
- When the unit exhibits a distinct change in performance - this indicates a need for service.

**Servicing** – Do not attempt to service the unit yourself as opening or removing covers may expose you to dangerous voltage or other hazards.

Refer to all servicing to qualified service personnel.

---

# Table of Contents

Overview .....	6
Introduction .....	7
About AIT Drives .....	7
Precautions .....	8
Installation .....	10
SCSI Connection/Setting the SCSI ID .....	10
Option Switches (DIP Switch) .....	11
Mounting Holes .....	14
Reconfiguring from 5.25" Model to 3.5" Model .....	15
Orientation .....	16
Attaching and Removing the Dust Cover .....	17
Attaching the Dust Cover .....	17
Removing the Dust Cover .....	19
Operation .....	20
Location of 3 LEDs .....	20
Drive Operation .....	21
Emergency Tape Removal Procedure .....	23
WORM Function .....	25
Interface Implementation .....	27
Supported SCSI Messages .....	27
Supported SCSI Commands .....	27
Specifications .....	28
Product Specifications .....	28
Sony Contacts .....	30

---

# Overview

The Sony SDX-700V series drives are high capacity data storage devices using Advanced Intelligent tape (AIT) technology. The SDX-700V series drives achieve high data reliability through Read-After-Write, an additional level of Error Correction Code, and other features.

The Sony SDX-700V series drives store data on tape using standard formats called AIT (Advanced Intelligent Tape) and ALDC.

---

# Introduction

## About AIT Drives

SDX-700V series drives are internal AIT drive units that use data cartridges conforming to the AIT-3 format. SDX-700V series drives support AIT-1, AIT-2, and AIT-3 formats.

## Features

The SDX-700V series drives have the following features:

- Support reading and writing to data cartridges conforming to the AIT-1, AIT-2, and AIT-3 formats.
- The Read After Write Function and third-level error correction code guarantee high data reliability.
- Data compression provides 260 gigabytes of storage on 230 m tape-length cartridge.<sup>\*1</sup>  
The native capacity is 100 gigabytes of storage on 230 m tape-length cartridge.
- Stored data is automatically checked for compression.
- Ultra 160 Wide SCSI LVD/SE interface is fully supported for host computer access.

<sup>\*1</sup> This is assuming 2.6 : 1 compression ratio.

The degree of data compression attained while recording data varies according to system environment and data type.

# Precautions

## Installation

Avoid placing the drives in locations subject to:

- high humidity
- high temperature
- mechanical shock and vibration
- direct sunlight

\* For details, see “Specifications” on page 28.

## Operation

- Do not move the drives while they are operating. It may cause malfunctions.
- Avoid exposing the drives to sudden changes from a low to high temperatures. This may cause water condensation to collect inside the drives. If the ambient temperature should suddenly rise while the drives are turned on, wait at least one hour before turning on the drives. If you attempt to operate the drives immediately after a sudden increase in temperature, malfunctions may occur.
- Turning off the power to the drives while they are writing to tape may cause the tape to become unreadable. All previously negotiated parameters will be lost, whenever power to the drives is cycled.

## Transportation

- Keep the original packing materials to facilitate safe transportation of the drives.
- Always remove the tape/media cartridge before moving the drives. After removing the drives from the computer, repack them into their original packing.

## Useable Cartridges

SDX-700V series can be used with data cartridges marked with the AIT-1, AIT-2 or AIT-3 logo.



### Note

Be sure to use only data cartridges designed specifically for AIT (do not use 8 mm video cartridges) as this may damage the drives.

## SCSI Termination

The SDX-700V series drives conform to the Microsoft PC97 standard, which requires the internal (naked) drive to be terminated with an external terminator.

### Microsoft PC97 SCSI requirements

SCSI peripherals must not terminate the bus. Both internal and external cable ends are instead terminated by plug-in connectors.

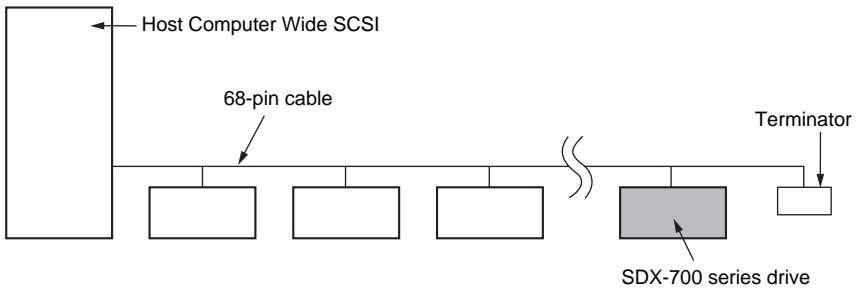

Example of SCSI setup

# Installation

## SCSI Connection/Setting the SCSI ID

SCSI ID	
SCSI ID	P.D. N.C. 3 2 1 0
0	
1	
2	
3	
4	
5	
6	
7	
8	
9	
10	
11	
12	
13	
14	
15	

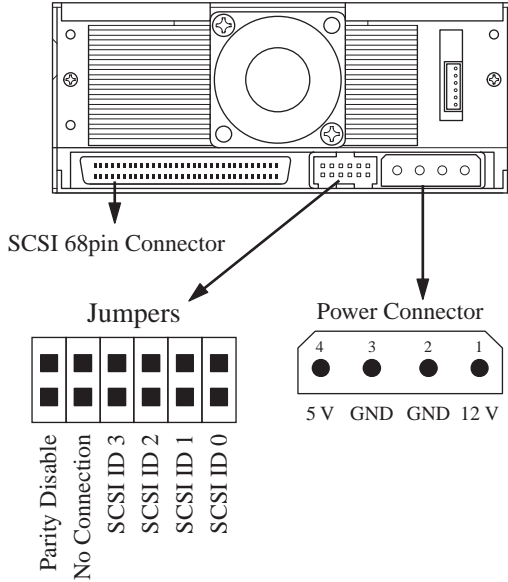

Parity	
Disable	
Enable	

**Note :** = CLOSED/Jumper  
 = OPEN/Jumper not installed  
 = Don't care

### Parity Disable Jumper

Parity check function can be disabled by Jumper. Parity check is disabled while left end jumper is installed. Parity generate function is always enabled.

## Option Switches (DIP Switch)

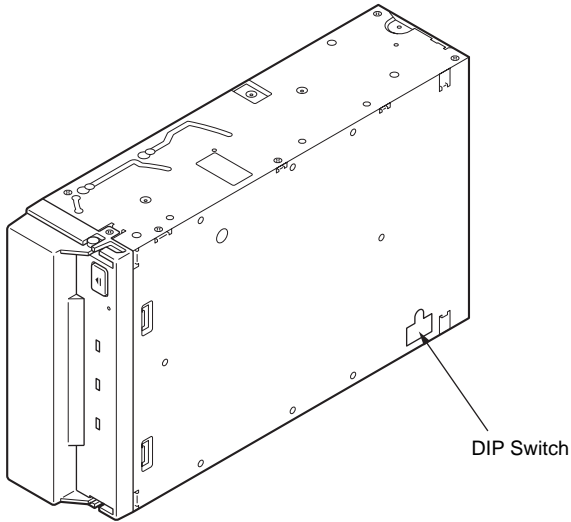

### DIP Switch Positions

#### Default



- 1 Drive Mode (OFF)
- 2 Drive Mode (OFF)
- 3 Drive Mode (OFF)
- 4 Drive Mode (OFF)
- 5 Terminator Power (ON)
- 6 Periodic Cleaning Req (ON)
- 7 DC Control (1) (ON)
- 8 DC Control (2) (OFF)

## DR (Disaster Recovery\*) Mode

To enable DR Mode, set position 1 [Drive Mode] switch to ON.

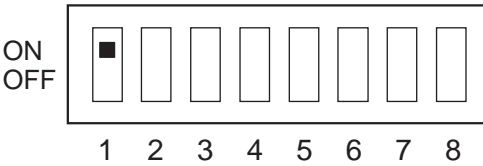

- 1 Drive Mode (ON)
- 2 Drive Mode
- 3 Drive Mode
- 4 Drive Mode
- 5 Terminator Power
- 6 Periodic Cleaning Req
- 7 DC Control (1)
- 8 DC Control (2)

\* In Disaster Recovery Mode, an SDX-700 series drive enters the DR Standby Mode 15 seconds after you insert a write-protected tape into the drive, and all the drive LED blink. If you restart the drive while the LED are blinking, it starts as a CD-ROM device.

For details about the Disaster Recovery Mode, refer to the instruction manual that came with the application software you are using.

## Emulation Mode\*

To enable Emulation Mode, set position 1 - 4 [Drive Mode] switches to ON.



- 1 Drive Mode (ON)
- 2 Drive Mode (ON)
- 3 Drive Mode (ON)
- 4 Drive Mode (ON)
- 5 Terminator Power
- 6 Periodic Cleaning Req
- 7 DC Control (1)
- 8 DC Control (2)

\* Emulation Mode returns the following in the Product Identification field of Inquiry of a SDX-700V series drive.

SDX-700C

## Data Compression Control DIP switch

Data compression can be selected by DIP switches. Data compression is enabled while position 7 [DC Control (1)] is ON. Control by host can be disabled when position 8 [DC Control (2)] is ON.

## Terminator Power Control DIP switch

This DIP switch determines whether terminator power is supplied to the SCSI bus. To enable terminator power, set position 5 [Terminator Power] switch to ON.

## Cleaning Request Mode

Periodic cleaning requests can be enabled by a DIP switch.

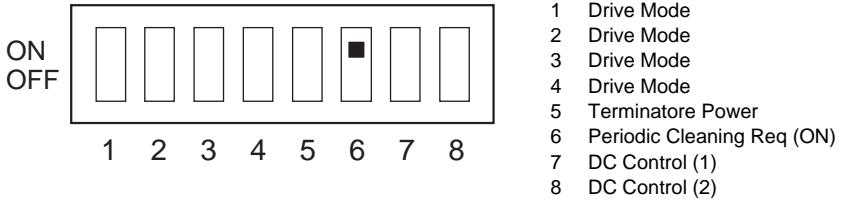

When switch 6 is ON, cleaning requests are enabled. When enabled, the “CLEANING REQUEST” LED on the front panel lights after every 100 hours of operation.

When this LED lights, clean the drive with a head cleaning cartridge.

### Note

To maintain the drive in optimum condition in environments affected by dust and other contaminants, we recommend keeping cleaning requests enabled.

# Mounting Holes

## For 3.5" Standard Height

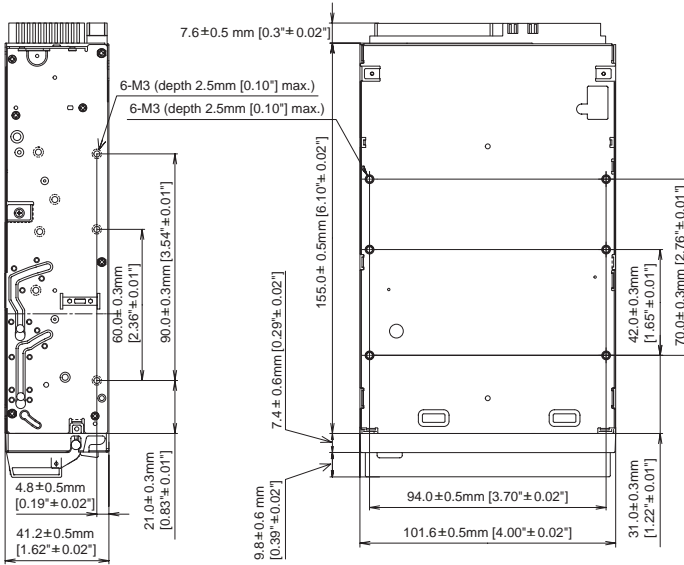

## For 5.25" Half Height

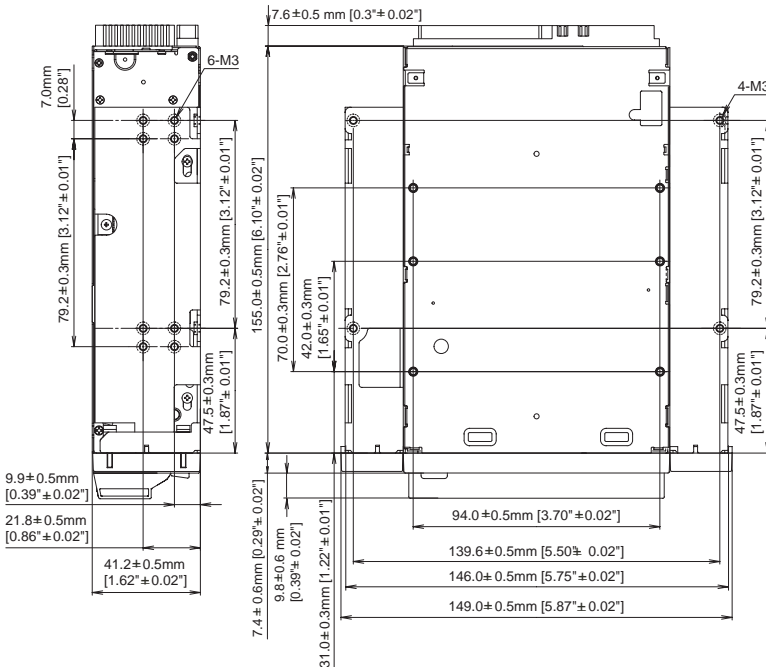

## Reconfiguring from 5.25" Model to 3.5" Model

You can reconfigure the 5.25" model to the 3.5" model yourself.

- 1** Remove the 2 screws for each side rail.
- 2** Take the side rail off.

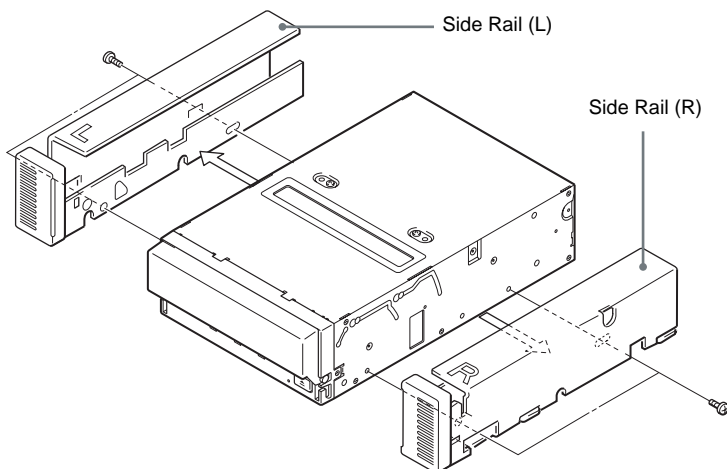

# Orientation

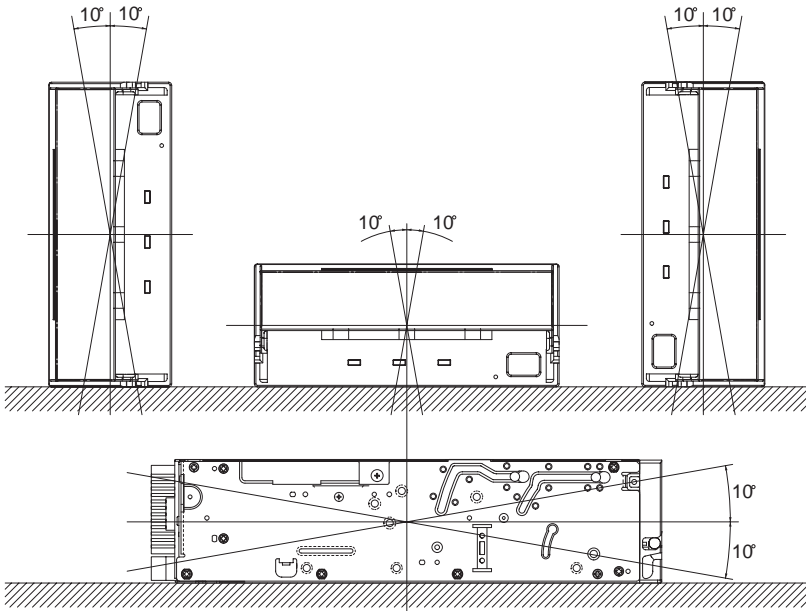

# Attaching and Removing the Dust Cover

## Attaching the Dust Cover

- 1 Align the dust cover's hinge clips (one on each side) with the pins of the drive bezel.
  - The dust cover should be positioned so that the magnets\* on the cover's back face the drive bezel.
  - \* This magnet does not affect the tape of the cartridge.
  - Holding the dust cover at an angle as shown in the figure below, set the hinge clips on top of the bezel pins, positioning them so that they bracket the pins.

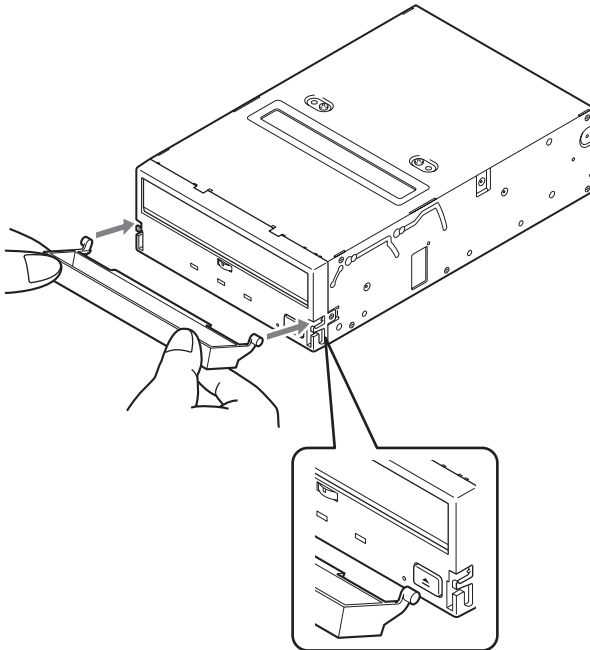

- 2** Press down at an angle on each side in turn until you hear the hinge clips click into place.

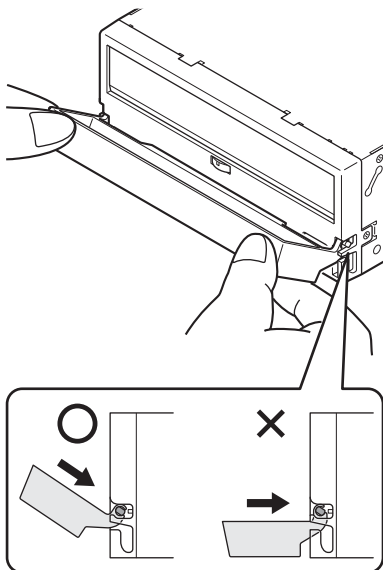

**Caution**

Do not press the dust cover in horizontally from the front. Doing so could cause the dust cover to break.

- 3** Close the dust cover.

This completes attachment of the dust cover.

## Removing the Dust Cover

- 1 Open the dust cover.
- 2 Holding the dust cover at both corners, carefully raise the dust cover.

The dust cover hinge clips and drive bezel pins uncouple.

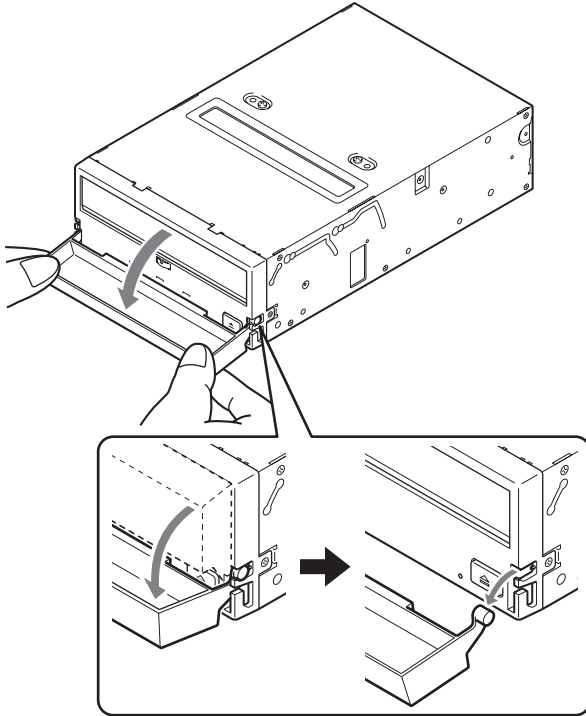

### Note

We recommend that you use the drive with the dust cover.

# Operation

## Location of 3 LEDs

There are three LED indicators (TAPE MOTION LED, CLEANING REQUEST LED, REPLACE TAPE LED) and an EJECT button on the front panel of the SDX-700V series drives.

### Front Panel

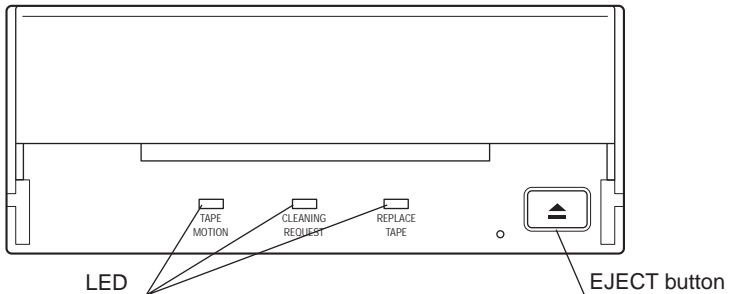

## LED Indication for Drive Status

The LED indicators are defined as follows

LED			Sense
TAPE MOTION	CLEANING REQUEST	REPLACE TAPE	
	Independent	Independent	Tape loaded
	Independent	Independent	Tape access in progress (write/read)
	Independent	Independent	Tape access in progress (others)
Independent		Independent	Cleaning is requested
Independent		Independent	Cleaning is not completed
Independent	Independent		Media error occurred
			H/W error occurred



on



Slow

1 pulse (0.9 sec on/0.3 sec off)



Fast

1 pulse (0.3 sec on/0.3 sec off)

## Drive Operation

### Loading a Cartridge

#### Note

While setting the data cartridge, do not turn off the host computer. This may cause a malfunction or damage data.

- 1** Turn on the host computer. Check that the drive's TAPE MOTION LED, CLEANING REQUEST LED and REPLACE TAPE LED go off.
- 2** Open the dust cover.

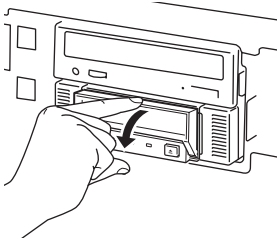

- 3** Set the AIT data cartridge orientation as shown here and insert it into the data cartridge slot.

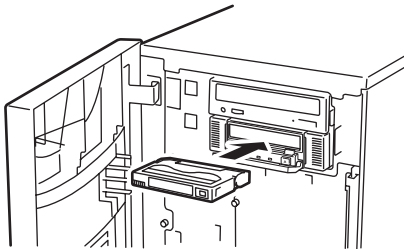

By inserting the data cartridge to the extent, it is automatically set in the drive and the TAPE MOTION LED lights.

## Unloading a Cartridge

The cartridge can be removed from SDX-700V series drives in response to a SCSI Unload command, or by pressing the EJECT button.

By pressing EJECT button, the tape is rewound and the cartridge ejected from the slot.

## Write-protecting a Cartridge

Cartridges can be write-protected by sliding the tab on the back of the cartridge. In this state, data can be read from the tape but not written onto it.

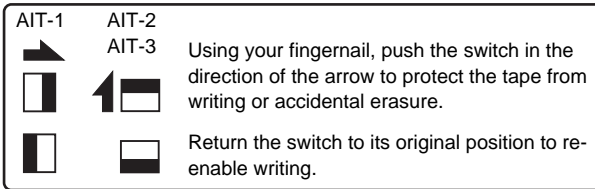
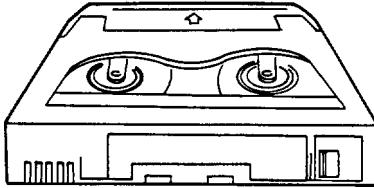

## Using a Cleaning Cartridge

A cleaning function is built into SDX-700V series drives so the use of a cleaning cartridge is not needed. If, however, the drive experiences excessive errors, the use of a Sony cleaning cartridge is recommended.

## Emergency Tape Removal Procedure

- 1** Remove the drive from the chassis or enclosure to allow access to the bottom of the drive.
- 2** Remove the drive's top cover.
- 3** Locate the small opening in the bottom of the drive and insert the tip of a precision screwdriver so that the Loading motor shaft can be rotated.
- 4** Rotate the motor shaft clockwise to bring the threading mechanism back to the initial position.

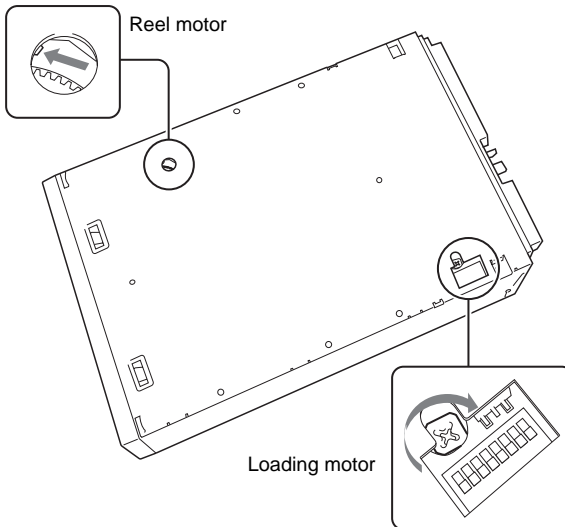

**Emergency Tape Removal Procedure**

**Caution**

Stop rotating the motor shaft immediately, when the guide B gets to the area below the line C-C (This line is defined by 2 circular tape guide surfaces of the cartridge). Otherwise, the gear of the drive can be damaged.

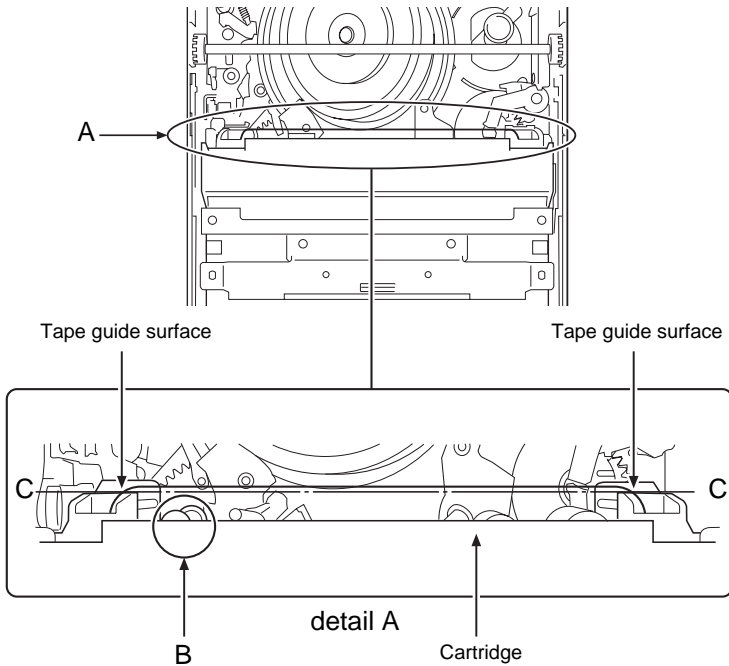

**The Initial Position of the Threading Mechanism**

- 5** Before the manual ejection procedure, tape slack must be removed in order to prevent tape damage. Rotate the gear mechanism located on the bottom of the drive counterclockwise to tighten the tape.
- 6** After the tape slack has been removed, continue to turn the Loading motor shaft located on the bottom of the drive clockwise with a precision screwdriver until the tape cartridge is lifted out of the drive mechanism and is ejected.
- 7** Return the drive to Sony for repair.

# WORM Function

SDX-700V series drives support the WORM function. This section explains the WORM function.

## What is “WORM”?

“WORM” is an acronym for “Write Once Read Many”, a function that allows data to be written to the same place on a tape only once, but permits that data to be read from the tape for any number of times. This drive supports WORM cartridges. When a WORM cartridge is used with an application that supports the WORM function, data that has been written to a tape can not be accidentally deleted or overwritten.

A WORM drive operates in the same manner as a non-WORM drive when used with a non-WORM cartridge (henceforth referred to as “regular cartridge”).

The operation of a WORM drive and a non-WORM drive differs according to the type of cartridge that is being used.

Tape Drive	Cartridge	
	Regular Cartridge (without WORM logo)	WORM Cartridge (with WORM logo)
Non-WORM drive	Read/Write Enabled	Waiting for Eject
WORM drive	Read/Write Enabled	Read/Append-Write Enabled

## WORM Cartridges

WORM cartridges can be distinguished from regular cartridges by their WORM logo and red shutters.

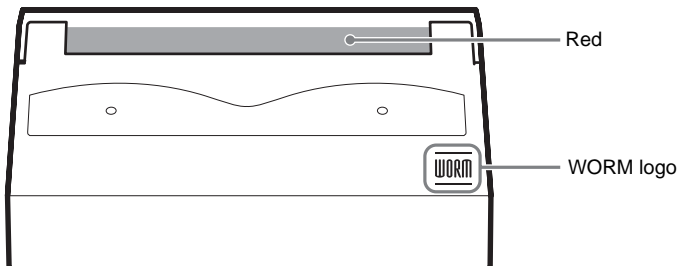

AIT-2 WORM cartridge: SDX2-50W

AIT-3 WORM cartridge: SDX3-100W

## How to Write Data onto a WORM Cartridge

As with a regular cartridge, there is no limit on how many times data can be read from a WORM cartridge. When writing data to a WORM cartridge, the data can not be written to a portion of the tape that has already been written.

When writing data onto a WORM cartridge, it is appended after data that has already been written onto the cartridge. Accordingly, you must move to the EOD area before writing data onto the cartridge.

## SCSI Commands Supported by WORM Drives

WORM drives support the same SCSI commands supported by non-WORM drives. However, if an attempt is made to write to a portion of a tape where data has already been written, the following error information is returned: “Sense Key = 07, ASC = 27h, ASCQ = 00: Persistent Write Protect” or “Sense Key=03, ASC=27h, ASCQ=04: Write Position Error.”

## AIT WORM-compliant Software

To find out whether your backup application is AIT WORM compliant, contact the manufacturer of the software.

### Notes

- Sony cannot accept liability for data written onto a WORM cartridge that is lost as a result of using this unit.
- Sony accepts no responsibility for any financial damages, lost profits, or claims made by third parties arising from the use of this product.

---

# Interface Implementation

## Supported SCSI Messages

Abort	Message Parity Error
Bus Device Reset	Message Reject
Command Complete	No Operation
Disconnect	Restore Pointers
Extended Message	Save Data Pointer
– Synchronous Data Transfer Request	
– Wide Data Transfer Request	
Identify ( w/&w/o Disconnect )	
Ignore Wide Residue	

## Supported SCSI Commands

Erase	Report Luns
Inquiry	Request Block Address
Load/Unload	Request Sense
Locate	Reserve Unit
Log Sense	Rewind
Log Select	Seek Block
Mode Select	Send Diagnostic
Mode Sense	Space
Prevent Allow Medium Removal	Test Unit Ready
Read	Verify
Read Block Limits	Write
Read Buffer	Write Buffer
Read Position	Write Filemarks
Receive Diagnostic Result	
Release Unit	
Report Density Support	

# Specifications

## Product Specifications

### Dimensions

(not including bezel and protruding parts)

	3.5"	5.25"
Height	41.2 mm (1.62 in)	41.2 mm (1.62 in)
Width	101.6 mm (4.0 in)	146.0 mm (5.75 in)
Depth	155.0 mm (6.1 in)	155.0 mm (6.1 in)

### Mass

3.5"	780 g (27.5 oz.)
5.25"	1050 g (37 oz.)

### Altitude

Operating	0 to 3048 m (0 to 10,000 ft.)
-----------	-------------------------------

### Vibration

Operating	Swept Sine 5 to 500 Hz *0.25 G Peak 1 Octave/min. 3 axes, 3 directions
Non-operating	Swept Sine 5 to 500 Hz *0.5 G Peak 1 Octave/min. 3 axes, 3 directions

### Acoustic Noise

(A) curve weight

Streaming Write/Read	35 dB (A)
Insert/Eject	60 dB (A)

### Note

The sound-meter on (A) scale is located 1m (3.3 ft.) in front of the center of the drive front panel.

## Shock

Operating	No Data Loss Half Sine Performance 5 G Peak 3 ms 3 axes, 3 directions *Interval of 10 seconds
Non-operating	No Device Damage Half Sine 90 G Peak 3 ms (30 G Peak 11 ms) 3 axes, 3 directions *Interval of 10 seconds

## Temperature and Humidity Range

### Temperature

Operating	5°C to 40°C ( $\Delta T < 10^\circ\text{C/h}$ ) (41°F to 104°F ( $\Delta T < 18^\circ\text{F/h}$ ))
Non-operating (mech.)	- 40°C to 70°C ( $\Delta T < 20^\circ\text{C/h}$ ) (- 40°F to 158°F ( $\Delta T < 36^\circ\text{F/h}$ ))
Non-operating (tape)	- 40°C to 45°C ( $\Delta T < 20^\circ\text{C/h}$ ) (- 40°F to 113°F ( $\Delta T < 36^\circ\text{F/h}$ ))

### Humidity

Operating	20 to 80% RH, non-condensing Maximum wet bulb temperature = 26°C (78.8°F)
Non-operating (mech.)	5 to 95% RH ( $\Delta\text{RH} < 30\%/h$ ) Maximum wet bulb temperature = 45°C (113°F)
Non-operating (tape)	20 to 80% RH ( $\Delta\text{RH} < 30\%/h$ )

## Air-cooling Requirement

Surrounding temperature	< 40°C (104°F)
-------------------------	----------------

Clean air flow is recommended to minimize the possibility of data loss.

## Power Requirements

Voltage	Max Ripple	Current	
		Typical	Maximum
5 V +/- 5 %	100 mVp-p	1.6 A	1.9 A
12 V +/- 10 %	150 mVp-p	0.5 A	1.2 A

---

# Sony Contacts

**For further information, please contact:**

**Sony Electronics Inc., Tape Storage Solutions (USA)**

URL: <http://www.storagebysony.com>

**Sony Corporation**

**Electronic Devices Marketing Group, Product Marketing Div.**

**Computer Peripherals Dept. Tape Streamer Section**

Osaki Gate City East Tower, 1-11-1, Osaki

Shinagawa-ku, Tokyo, 141-0032 Japan

TEL: (81) 3-5435-3486      FAX: (81) 3-5435-3565

**Sony of Canada Ltd., AV/IT Marketing Group**

**Computer Peripherals Product Marketing**

115 Gordon Baker Road Toronto, Ontario, M2H 3R6 Canada

TEL: (416) 499-1414 or (1) 800-961-7669

FAX: (416) 499-8541

**Sony Business Europe**

URL: <http://www.sonyisstorage.com/>

**Electronics Devices Marketing (Singapore)**

**(A division company of Sony Electronics (S) Pte. Ltd.)**

**Enterprise Storage Solutions Dept.**

2 International Business Park, #01-10 Tower One,

The Strategy, Singapore 609930

TEL: 65-6544-8000      FAX: 65-6544-7390

**Sony Corporation of Hong Kong Ltd.**

**Computer Peripheral Sales & Marketing Division**

**Electronic Devices Marketing Hong Kong**

45/F, The Lee Gardens, 33 Hysan Avenue, Causeway Bay, Hong Kong

TEL: (852) 2909-1008      FAX: (852) 2909-2001

**Sony Corporation of Hong Kong Ltd. Beijing Rep. Office**

**Computer Peripheral Div.**

Full Link Plaza Tower A 11/F., No.18 Chaoyangmenwai Ave., Beijing  
100020 P.R.C.

TEL: 86-10-6588-0558      FAX: 86-10-6588-0855

URL: <http://www.sony.com.cn>

**Sony Corporation of Hong Kong Ltd. Shanghai Rep. Office**

44F., HSBC Tower, 101 Yin Cheng East Road, Pudong, New Area,  
Shanghai, P.R.C. Postcode 200120

TEL: 86-21-6841-3222      FAX: 86-21-6841-0280

**Sony Brasil Ltda.**

Rua Inocência Tobias, 125-BlocoA, CEP01144-000, São Paulo -SP-Brasil

TEL: (55) 11-3824-6586 to 6598 FAX: (55) 11-3611-9064

URL: <http://www.sonybrasil.com>

**Sony Australia Limited**

33-39 Talavera Rd.

NORTH RYDE, NSW 2113

TEL: 1300-13-7669 FAX: 02-9870-5864

e-mail: [CIC-customerissues@ap.sony.com](mailto:CIC-customerissues@ap.sony.com)

**Sony New Zealand**

Akoranga Business Park

NORTH SHORE, AUCKLAND

TEL: 0800-76-6969 FAX: 09-308-9300

e-mail: [CIC-customerissues@ap.sony.com](mailto:CIC-customerissues@ap.sony.com)

**Sony Chile Ltda**

Av. Kennedy 8017, Las Condes, Santiago, Chile

TEL: (02) 210-6000      FAX: (02) 210-5417

**Sony Taiwan Limited**

**Optical Devices Storage Dept. Data Storage Section**

5F, 145 Changchun Road, Taipei 104, Taiwan

TEL: 886-2-2522-7920      FAX: 886-2-2522-2153

**Sony Korea Corporation EDMK CP Sales & Marketing Team**

34F, ASEM Tower, World Trade Center, 159-1, Samsung-Dong,  
Kangnam-Ku, Seoul, 135-798, Korea

TEL: 82-2-6001-4249      FAX: 82-2-6001-4115

URL: <http://www.sony.co.kr/cp/>

**Sony Gulf FZE Computer Display & Peripheral Div.**

P.O.BOX 16871, Jebel Ali, Dubai, U.A.E.

TEL: 971-4-8815488 or 8816912      FAX: 971-4-8817210 or 8816259

**Sony Marketing of Japan**

Business Solution Dept. Server Solution Marketing Section

URL: <http://www.sony.co.jp/STORAGE>

