

---

## Description

The CXA3813N is a headphone amplifier and 2-channel stereo audio line amplifiers IC. Each amplifier has a fixed gain and mute function.

Pop noise of 2-channel stereo audio line amplifiers is free at power on/off and Mute.

1-channel stereo audio line amplifier has 2 stereo input multiplexer.

The CXA3813N is suitable for a wide range of consumer audio applications, such as portable A/V players, set-top boxes, and digital televisions. The device is offered in a space saving 24pin SSOP package.

---

## Features

- |   |  |
|---|--|
| ◆ Headphone amplifier                     | +12dB fixed gain   |
| ◆ 2-channel audio line amplifier          | Amplifier1: +12dB fixed gain<br>Amplifier2: +12dB fixed gain, 2 stereo input multiplexer |
| ◆ Operating voltage                       | $V_{CC\_HP} = V_{CC\_AMP1} = 8$ to 14V   |
| ◆ Operating current                       | 12mA typ. ( $V_{CC\_HP}$ ), 30mA typ. ( $V_{CC\_AMP1}$ )                                 |
| ◆ Pop noise free at power On/Off and mute | Amplifier1 and Amplifier2  |
| ◆ Package                                 | SSOP24   |

Sony reserves the right to change products and specifications without prior notice. This information does not convey any license by any implication or otherwise under any patents or other right. Application circuits shown, if any, are typical examples illustrating the operation of the devices. Sony cannot assume responsibility for any problems arising out of the use of these circuits.

### Absolute Maximum Ratings

Item	Symbol	Rating	Unit
Supply voltage	V <sub>CC</sub>	24.0	V
Operating temperature range	T <sub>A</sub>	-25 to +85	°C
Storage temperature range	T <sub>stg</sub>	-55 to +125	°C
Junction temperature	T <sub>J(max)</sub>	+125	°C
Power dissipation	P <sub>d</sub>	$(T_{J(max)} - T_A) / \theta_{JA}^{*1}$	—
Thermal impedance	$\theta_{JA}$	131.9	°C/W
	$\theta_{JC}$	0.6	°C/W

\*1 Glass fabric base epoxy two-layer board, 76mm × 114mm, t = 1.6mm

### Recommended Operating Conditions

Item	Symbol	Min.	Typ.	Max.	Unit
Supply voltage	V <sub>CC</sub>	8.0	12.0	14.0	V
Operating ambient temperature	T <sub>opt</sub>	-25	—	+85	°C

Block Diagram

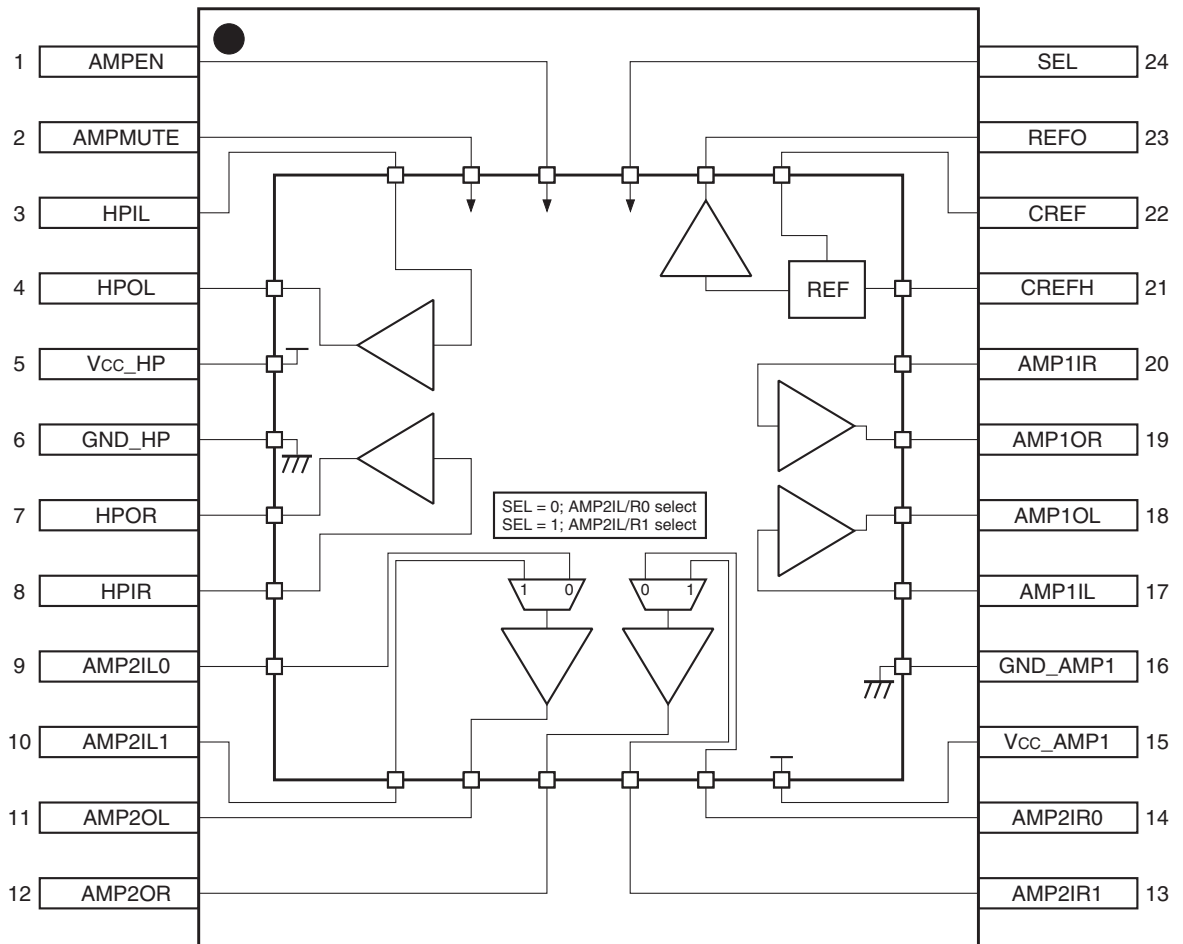

## Pin Description

Pin No.	Pin name	Direction	Description
1	AMPEN	I	Amplifier enable control signal input
2	AMPMUTE	I	Amplifier mute control signal input
3	HPIL	I	Headphone amplifier Lch input
4	HPOL	O	Headphone amplifier Lch output
5	Vcc_HP	—	Headphone amplifier power
6	GND_HP	—	Headphone amplifier ground
7	HPOR	O	Headphone amplifier Rch output
8	HPIR	I	Headphone amplifier Rch input
9	AMP2IL0	I	AMP2 Lch selector input 0
10	AMP2IL1	I	AMP2 Lch selector input 1
11	AMP2OL	O	AMP2 Lch output
12	AMP2OR	O	AMP2 Rch output
13	AMP2IR1	I	AMP2 Rch selector input 1
14	AMP2IR0	I	AMP2 Rch selector input 0
15	Vcc_AMP1	—	AMP1, 2 and reference power
16	GND_AMP1	—	AMP1, 2 and reference ground
17	AMP1IL	I	AMP1 Lch input
18	AMP1OL	O	AMP1 Lch output
19	AMP1OR	O	AMP1 Rch output
20	AMP1IR	I	AMP1 Rch input
21	CREFH	O	“H” reference capacitor
22	CREF	O	Reference capacitor
23	REFO	O	All amplifier reference
24	SEL	I	AMP2 selector control signal input

Pin Circuits

Pin No.	Symbol	Equivalent circuit
<p>1 2 24</p>	<p>AMPEN AMPMUTE SEL</p>	
<p>3 8</p>	<p>HPIL HPIR</p>	
<p>4 7</p>	<p>HPOL HPOR</p>	
<p>9 10 13 14</p>	<p>AMP2IL0 AMP2IL1 AMP2IR1 AMP2IR0</p>	

Pin No.	Symbol	Equivalent circuit
<p>11 12 18 19</p>	<p>AMP2OL AMP2OR AMP1OL AMP1OR</p>	
<p>17 20</p>	<p>AMP1IL AMP1IR</p>	
<p>21 22</p>	<p>CREFH CREF</p>	
<p>23</p>	<p>REFO</p>	

Reference Block

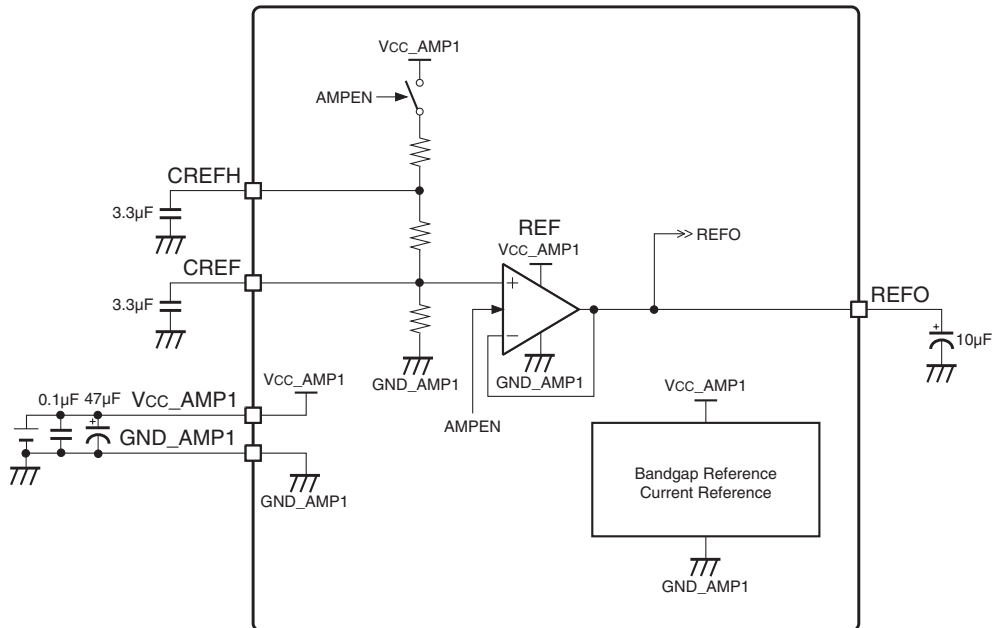

Electrical Characteristics

◆ Electrical Characteristics (Reference)

(unless otherwise specified; Ta = 25°C, Vcc = 12.0V, fsignal = 1kHz, Measurement band width = 20 to 20kHz)

Item	Symbol	Min.	Typ.	Max.	Condition	Unit
CREF output voltage	V <sub>CREF</sub>	$(V_{cc}/2) \times 0.9$	$V_{cc}/2$	$(V_{cc}/2) \times 1.1$		V
CREFH output voltage	V <sub>CREFH</sub>	$(3 \times V_{cc}/4) \times 0.9$	$3 \times V_{cc}/4$	$(3 \times V_{cc}/4) \times 1.1$		V
REFO output voltage	V <sub>REFO</sub>	$(V_{cc}/2) \times 0.9$	$V_{cc}/2$	$(V_{cc}/2) \times 1.1$		V

◆ Electrical Characteristics (Operating Current)

(unless otherwise specified; Ta = 25°C, Vcc = 12.0V, fsignal = No-signal, Measurement band width = 20 to 20kHz)

Item	Symbol	Min.	Typ.	Max.	Condition	Unit
Power-down mode (AMPEN pin = "L")	I <sub>STB_HP</sub>	—	50.0	90.0	V <sub>cc_HP</sub> = 12V, No-load, No-signal	µA
	I <sub>STB_AMP1</sub>	—	2.0	3.6	V <sub>cc_AMP1</sub> = 12V, No-load, No-signal	mA
Normal operating current (AMPEN pin = "H")	I <sub>ACT_HP</sub>	—	12.0	22.0	V <sub>cc_HP</sub> = 12V, No-load, No-signal	mA
	I <sub>ACT_AMP1</sub>	—	30.0	55.0	V <sub>cc_AMP1</sub> = 12V, No-load, No-signal	mA

HP Block

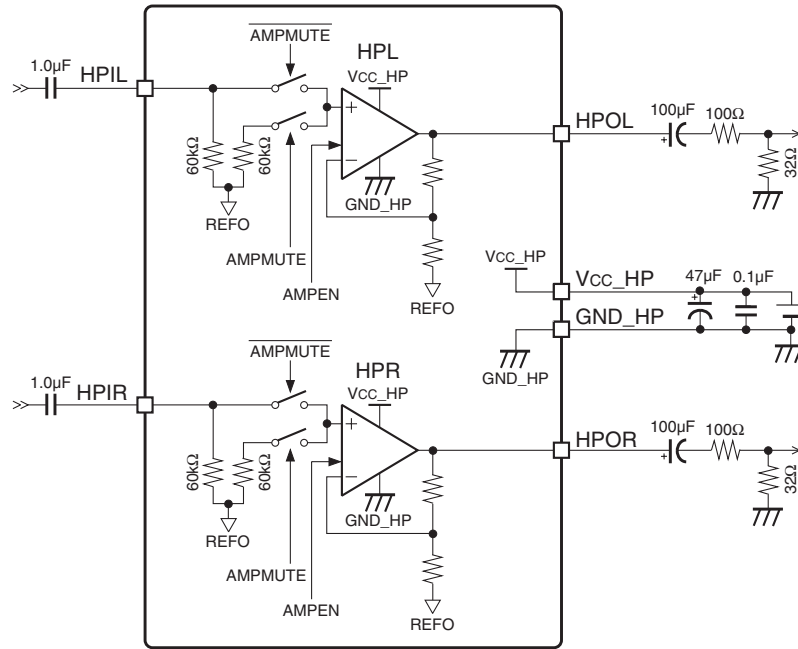

Electrical Characteristics

◆ Electrical Characteristics (HP Block)

(unless otherwise specified; Ta = 25°C, Vcc = 12.0V, fsignal = 1kHz, Measurement band width = 20 to 20kHz)

Item	Symbol	Min.	Typ.	Max.	Condition	Unit
HPAMP input impedance	RINHP	48.0	60.0	72.0		kΩ
Output DC voltage	VOUHP	(Vcc/2) × 0.9	Vcc/2	(Vcc/2) × 1.1	AC coupled input	V
HPAMP gain	GAINHP1	11.0	12.0	13.0	fsig = 1kHz	dB
Maximum output level	VOMHP	2.8	—	—	RL = 100Ω + 32Ω, Vcc = 12.0V	Vrms
THD+N	THDHP1	—	0.1	0.5	RL = 100Ω + 32Ω, Vin = 0.5Vrms, Vcc = 12.0V	%
	THDHP2	—	1.0	10.0	RL = 100Ω + 32Ω, Vin = 0.7Vrms, Vcc = 12.0V	%
Output noise level	VNHP1	—	-96.0	-90.0	RL = 100Ω + 32Ω, Vin = No-signal, Measured at RL of 32Ω	dBV
Gain error	GEHP	-0.5	0	0.5	RL = 10kΩ, Vcc = 12.0V	dB
Channel separation	CSHP	60.0	70.0	—	HPOL/R = 2.8Vrms/No-signal, 1kHz BPF, Rg = 1kΩ	dB
Cross talk	CTHP	60.0	70.0	—	HPOL/R = No-signal, AMP1, 2OL/R = 2.8Vrms, 1kHz BPF, Rg = 1kΩ	dB
PSRR	PSRRHP	30.0	40.0	—	HPOL/R = No-signal, fsig = 1kHz	dB

AMP1 Block

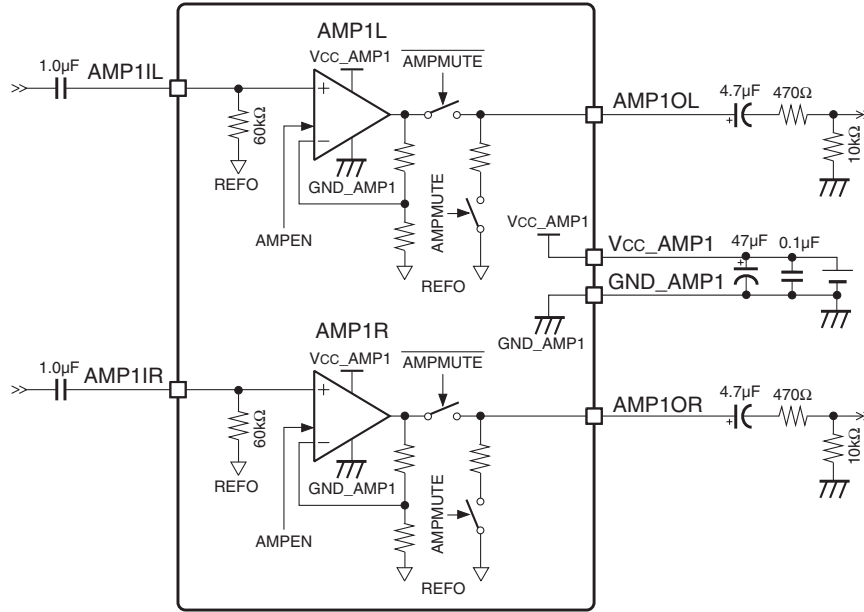

Electrical Characteristics

◆ Electrical Characteristics (AMP1 Block)

(unless otherwise specified; Ta = 25°C, Vcc = 12.0V, fsignal = 1kHz, Measurement band width = 20 to 20kHz)

Item	Symbol	Min.	Typ.	Max.	Condition	Unit
AMP1 input impedance	RINAMP1	48.0	60.0	72.0		kΩ
Output DC voltage	VOUTAMP1	$(V_{cc}/2) \times 0.9$	$V_{cc}/2$	$(V_{cc}/2) \times 1.1$	AC coupled input	V
AMP1 gain	GAINAMP1	11.0	12.0	13.0	fsig = 1kHz	dB
Maximum output level	VOMAMP1	2.8	—	—	RL = 10kΩ, Vcc = 12.0V	Vrms
THD+N	THDAMP1_1	—	0.1	0.5	RL = 10kΩ, Vin = 0.5Vrms, Vcc = 12.0V	%
	THDAMP1_2	—	1.0	10.0	RL = 10kΩ, Vin = 0.7Vrms, Vcc = 12.0V	%
Output noise level	VNAMP1	—	-93.0	-87.0	RL = 10kΩ, Vin = No-signal	dBV
Gain error	GEAMP1	-0.5	0	0.5	RL = 10kΩ, Vcc = 12.0V	dB
Channel separation	CSAMP1	60.0	70.0	—	AMP1OL/R = 2.8Vrms/No-signal, 1kHz BPF, Rg = 1kΩ	dB
Cross talk	CTAMP1	60.0	70.0	—	AMP1OL/R = No-signal, HPOL/R = 2.8Vrms, AMP2OL/R = 2.8Vrms, 1kHz BPF, Rg = 1kΩ	dB
PSRR	PSRRAMP1	30.0	40.0	—	AMP1OL/R = No-signal, fsig = 1kHz	dB

AMP2 Block

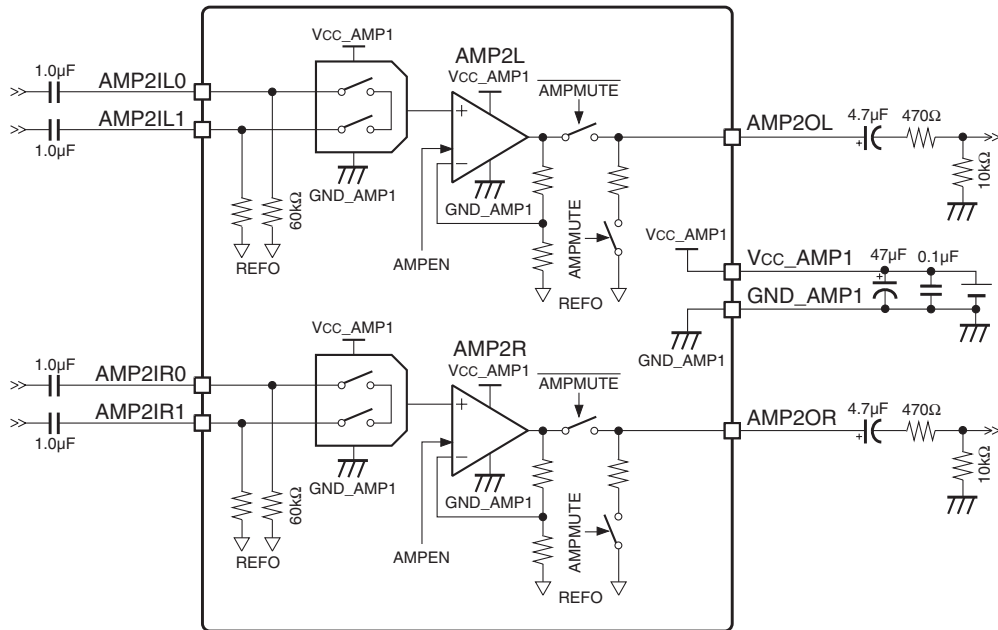

Electrical Characteristics

◆ Electrical Characteristics (AMP2 Block)

(unless otherwise specified; Ta = 25°C, Vcc = 12.0V, fsignal = 1kHz, Measurement band width = 20 to 20kHz)

Item	Symbol	Min.	Typ.	Max.	Condition	Unit
AMP2 input impedance	RINAMP1	48.0	60.0	72.0		kΩ
Output DC voltage	VOUTAMP2	$(V_{cc}/2) \times 0.9$	$V_{cc}/2$	$(V_{cc}/2) \times 1.1$	AC coupled input	V
AMP2 gain	GAINAMP2	11.0	12.0	13.0	fsig = 1kHz	dB
Maximum output level	VOMAMP2	2.8	—	—	RL = 10kΩ, Vcc = 12.0V	Vrms
THD+N	THDAMP2_1	—	0.1	0.5	RL = 10kΩ, Vin = 0.5Vrms, Vcc = 12.0V	%
	THDAMP2_2	—	1.0	10.0	RL = 10kΩ, Vin = 0.7Vrms, Vcc = 12.0V	%
Output noise level	VNAMP2	—	-93.0	-87.0	RL = 10kΩ, Vin = No-signal	dBV
Gain error	GEAMP2	-0.5	0	0.5	RL = 10kΩ, Vcc = 12.0V	dB
Channel separation	CSAMP2	60.0	70.0	—	AMP2OL/R = 2.8Vrms/No-signal, 1kHz BPF, Rg = 1kΩ	dB
Cross talk	CTAMP2	60.0	70.0	—	AMP2OL/R = No-signal, HPOL/R = 2.8Vrms, AMP1OL/R = 2.8Vrms, 1kHz BPF, Rg = 1kΩ	dB
PSRR	PSRRAMP2	30.0	40.0	—	AMP2OL/R = No-signal, fsig = 1kHz	dB

Control Block

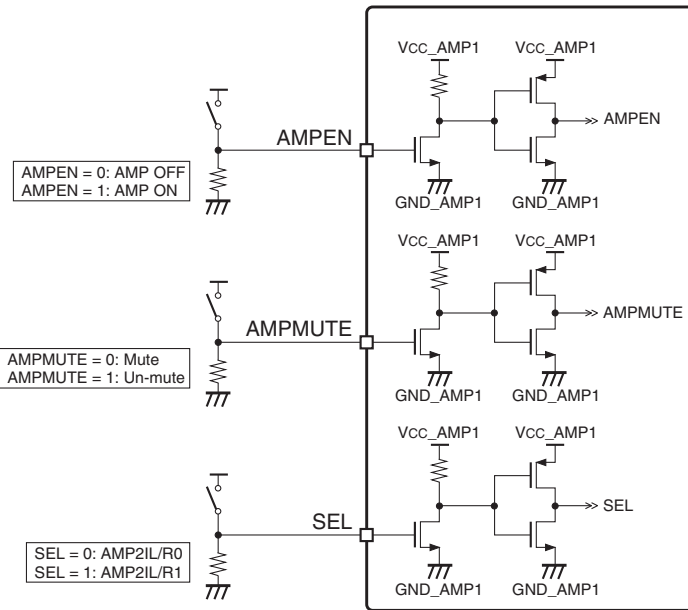

Electrical Characteristics

◆ Electrical Characteristics (Control Block)

(unless otherwise specified; Ta = 25°C, Vcc = 12.0V, fsignal = 1kHz, Measurement band width = 20 to 20kHz)

Item	Symbol	Min.	Typ.	Max.	Condition	Unit
AMPEN High level input voltage	VAMPENH	2.0	—	Vcc_AMP1	Input: High level	V
AMPEN Low level input voltage	VAMPENL	0	—	0.4	Input: Low level	V
AMPMUTE High level input voltage	VAMPMUTEH	2.0	—	Vcc_AMP1	Input: High level	V
AMPMUTE Low level input voltage	VAMPMUTEL	0	—	0.4	Input: Low level	V
SEL High level input voltage	VSELH	2.0	—	Vcc_AMP1	Input: High level	V
SEL Low level input voltage	VSELL	0	—	0.4	Input: Low level	V

◆ AMPEN

Amplifier enable control

- “L” Amp Off
- “H” Amp On

◆ AMPMUTE

Amplifier mute control

- “L” Mute
- “H” Un-mute

◆ SEL

AMP2 selector control

- “L” AMP2IL/R0 select
- “H” AMP2IL/R1 select

## Power-On/Off Sequence

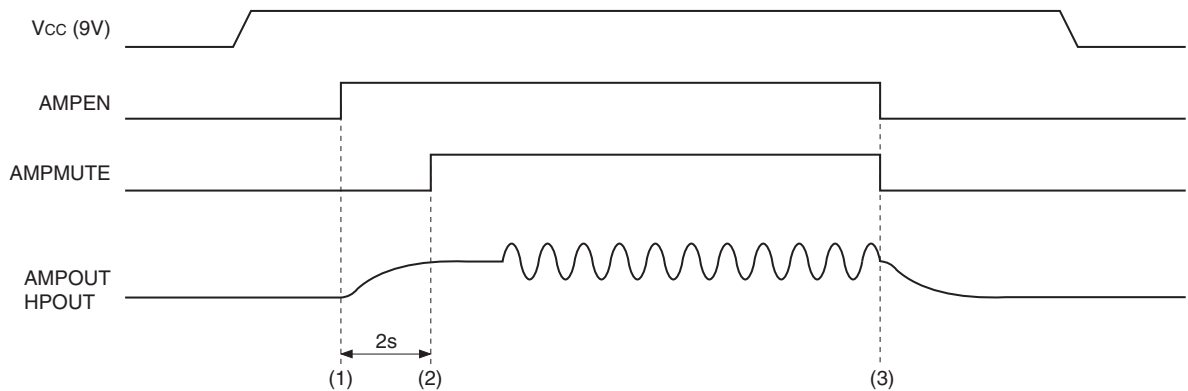

### Power-On Sequence

- (1) Amplifier and BIAS enable signal (AMPEN) should be set to "H".
- (2) Amplifier output switch control signal (AMPMUTE) should be set to "H" at least 2s after (1).

### Power-Off Sequence

- (3) AMPEN and AMPMUTE signal should be set to "L" at the same time. \*1

\*1 AMPMUTE should be first "L" if it is impossible to be "L" at the same time.

Application Circuit

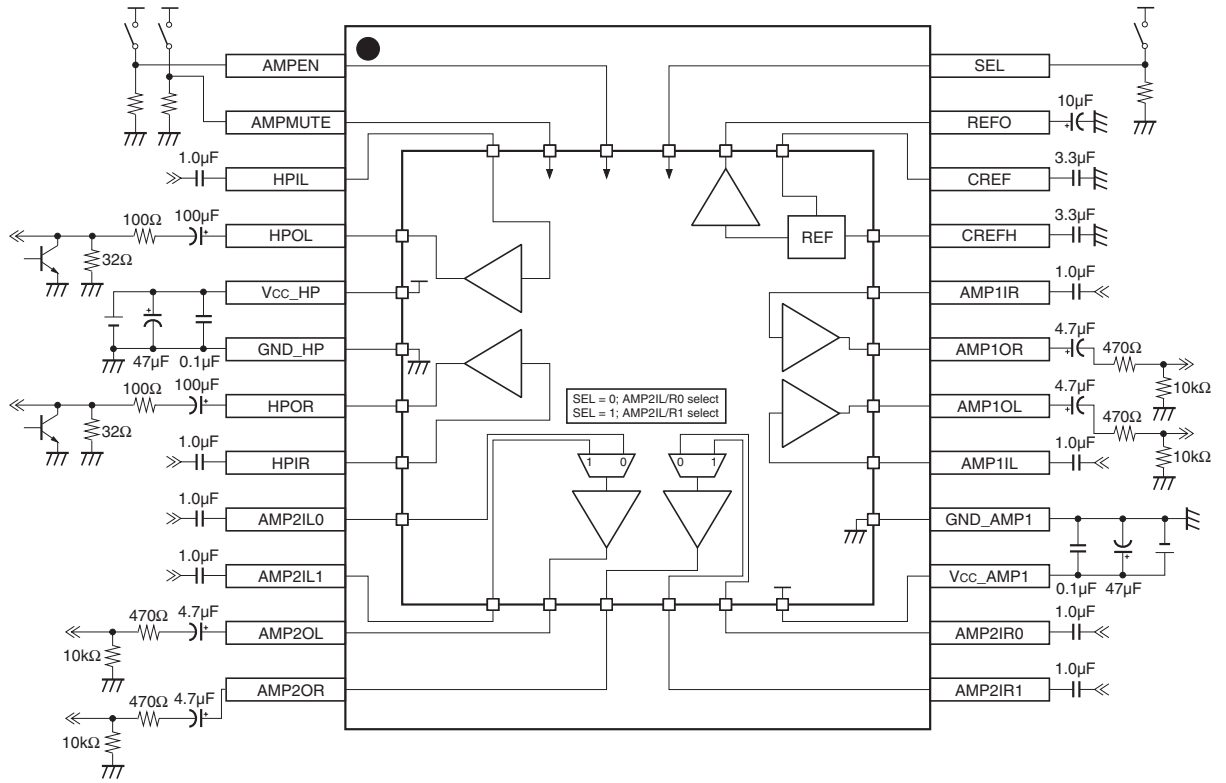

Application circuits shown are typical examples illustrating the operation of the devices. Sony cannot assume responsibility for any problems arising out of the use of these circuits or for any infringement of third party patent and other right due to same.

Package Outline

(Unit: mm)

24PIN SSOP (PLASTIC)

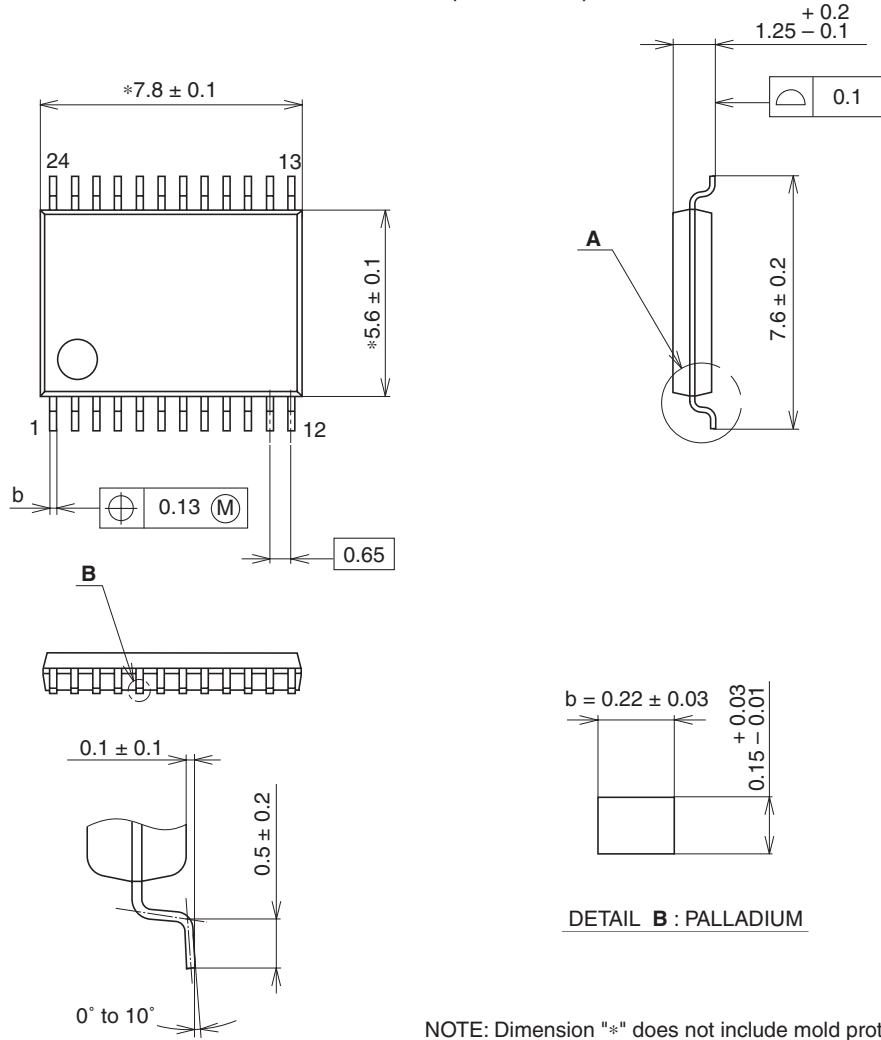

DETAIL A

DETAIL B : PALLADIUM

NOTE: Dimension "\*" does not include mold protrusion.

PACKAGE STRUCTURE

SONY CODE	SSOP-24P-L01
EIAJ CODE	P-SSOP24-7.8x5.6-0.65
JEDEC CODE	—

PACKAGE MATERIAL	EPOXY RESIN
LEAD TREATMENT	PALLADIUM PLATING
LEAD MATERIAL	COPPER ALLOY
PACKAGE MASS	0.1g