

CXG1407XR

Description

The CXG1407XR can be selected four kinds of built-in capacitor (1 to 8 pF), or two path. Sony JPHEMT GaAs process is utilized for low insertion loss, high linearity and high Q Factor capacitance with high accuracy.

(Applications: Antenna tuning, i.e Felica characteristics)

Features

- ◆ Low insertion loss (internal switch)
- ◆ Low voltage drive: 2.4 to 3.3 V
- ◆ High Q Factor, high accuracy capacitance
- ◆ Robustness against ESD
- ◆ Small package: 12-pin XQFN (2.0 mm × 2.0 mm × 0.4 mm Max.)
- ◆ Lead-Free and RoHS Compliant

Structure

GaAs Junction Gate pHEMT (JPHEMT) MMIC

Absolute Maximum Ratings

Input voltage Max.	Vctl	+4	V (Ta = 25 °C)
Input voltage Min.	Vctl	-0.2	V (Ta = 25 °C)
Maximum input.		35	dBm (Ta = 25 °C)
Operating temperature		-30 to +90	°C
Storage temperature		-65 to +150	°C

This IC is ESD sensitive device. Special handling precautions are required.

Block Diagram

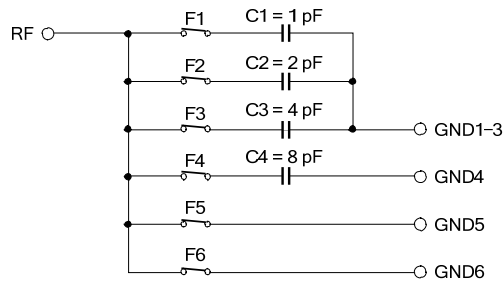

Pin Configuration

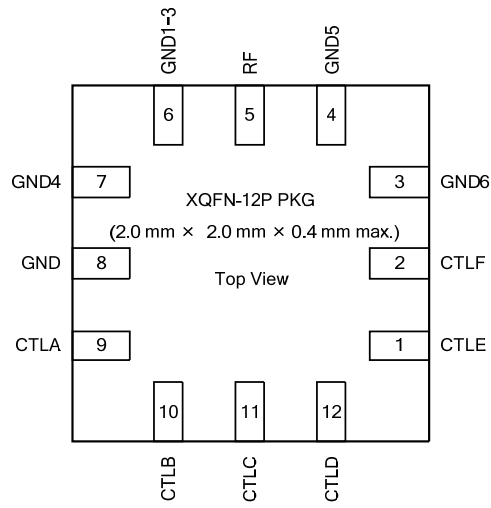

Truth Table

CTLA	CTLB	CTLC	CTLD	CTLE	CTLF	F1	F2	F3	F4	F5	F6
L	—	—	—	—	—	OFF	—	—	—	—	—
H	—	—	—	—	—	ON	—	—	—	—	—
—	L	—	—	—	—	—	OFF	—	—	—	—
—	H	—	—	—	—	—	ON	—	—	—	—
—	—	L	—	—	—	—	—	OFF	—	—	—
—	—	H	—	—	—	—	—	ON	—	—	—
—	—	—	L	—	—	—	—	—	OFF	—	—
—	—	—	H	—	—	—	—	—	ON	—	—
—	—	—	—	L	—	—	—	—	—	OFF	—
—	—	—	—	H	—	—	—	—	—	ON	—
—	—	—	—	—	L	—	—	—	—	—	OFF
—	—	—	—	—	H	—	—	—	—	—	ON

Note) 1. [—] : Don't Care
 2. It is prohibited that all control inputs are L.

DC Bias Condition

(Temperature = -30 to +90 °C)

Item	Min.	Typ.	Max.	Unit
Vctl (H)	2.4	2.8	3.3	V
Vctl (L)	0	—	0.3	

Electrical Characteristics

(Ta = 25 °C, Vctl = 2.4 to 3.3 V/0 V)

Item	Symbol	Path	Condition	Min.	Typ.	Max.	Unit
Transmission performance	S21	RF-GND1	*1	—	36.5	39.5	dB
			*2	—	4.9	5.7	
		RF-GND2	*1	—	32.6	35.6	
			*2	—	2.9	3.5	
		RF-GND3	*1	—	28.2	31.2	
			*2	—	1.6	2.05	
		RF-GND4	*1	—	23.4	26.4	
			*2	—	1.1	1.4	
		RF-GND51	*1	—	0.15	0.30	
			*2	—	0.56	0.71	
RF-GND6	*1	—	0.16	0.31			
	*2	—	0.56	0.71			
Isolation	IOS	RF-GND1 to 3	*2	10	15	—	dB
		RF-GND4	*2	15	20	—	
		RF-GND5	*2	15	20	—	
		RF-GND6	*2	15	20	—	
Harmonics	2fo	RF-GND5	*3	55	75	—	dBc
	3fo		*3	55	67	—	
	2fo	RF-GND6	*3	55	75	—	
	3fo		*3	55	67	—	
P _{0.2 dB} compression	P _{0.2 dB}	RF-GND5	*4	—	33	—	dBm
		RF-GND6	*4	—	33	—	
Capacitance	C1	GND1	*5	1.86	2.01	2.16	pF
	C2	GND2	*5	2.83	3.05	3.27	
	C3	GND3	*5	4.60	4.95	5.30	
	C4	GND4	*5	7.74	8.33	8.92	
Capacitance ratio	C2-1	—	C2/C1	1.44	1.52	1.60	—
	C3-2	—	C3/C2	1.53	1.62	1.71	
	C4-3	—	C4/C3	1.59	1.68	1.77	
Switching speed	SWT	RF-GND1 to 6	—	—	—	5.0	μs
Ictl	Ictl	VCTL = ALL_H	VCTL = 2.8 V	—	1.9	4.0	μA

*1 Pin = 0 dBm, frequency = 13.56 MHz

*2 Pin = 0 dBm, frequency = 900 MHz

*3 Pin = 27 dBm, frequency = 900 MHz

*4 Frequency = 900 MHz

*5 Pin = 0 dBm, Calculated by S-parameter at 13.56 MHz

Recommended Circuit

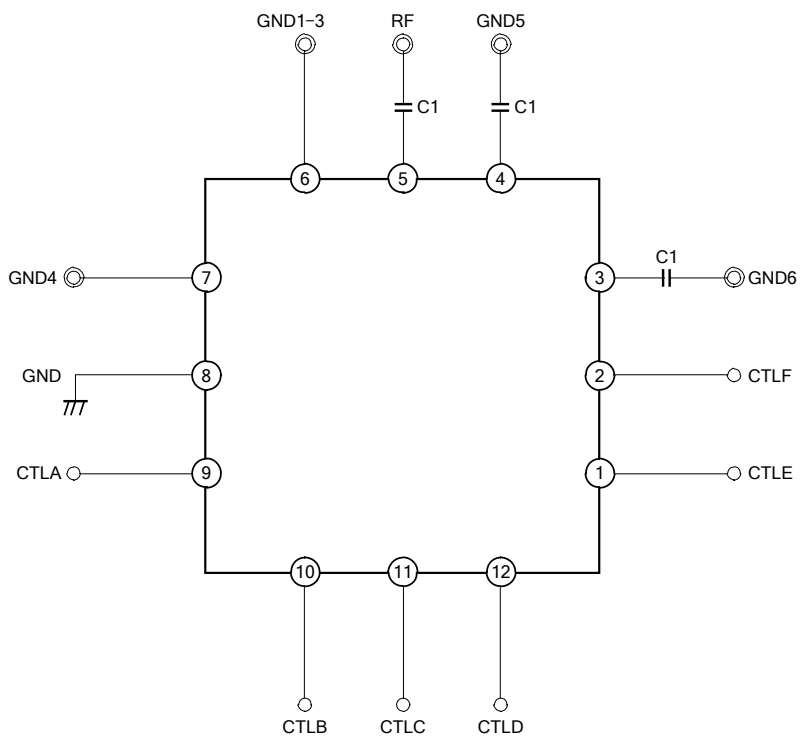





* C1 = DC cut capacitor (10000 pF)

PCB Layout Template

XQFN-12P-02 Macro drawing (Reference)

•PKG : 2.0mm×2.0mm
 •Pin pitch : 0.4mm

*Metal mask thickness : 110μm

-  : Land
-  : Mask (Open area)
-  : Resist (Open area)
-  : Metal area in board (*1)

*1:GND plane is recommended.
 A metallic layer (GND) is necessary
 for this area to keep the performance.

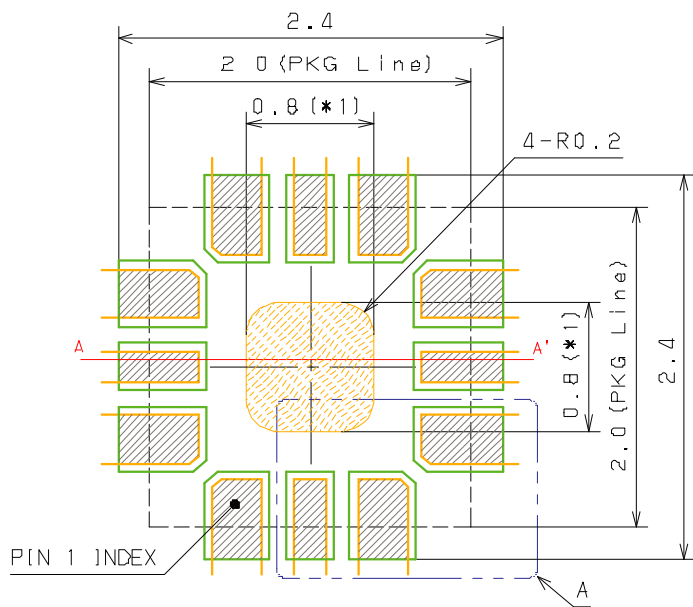

Detail A

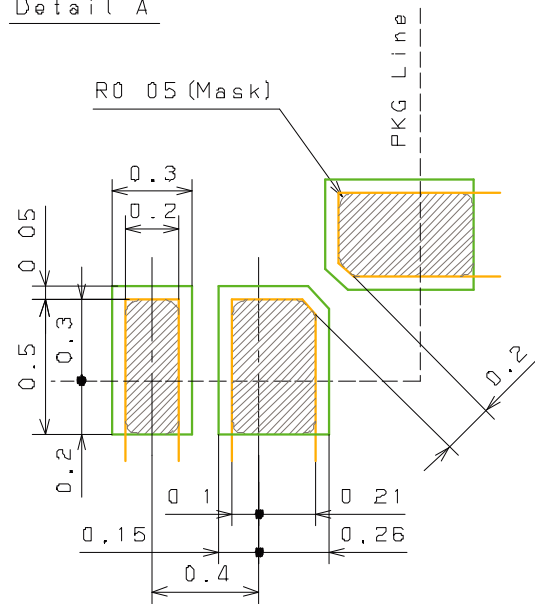

A-A' Cross Section view

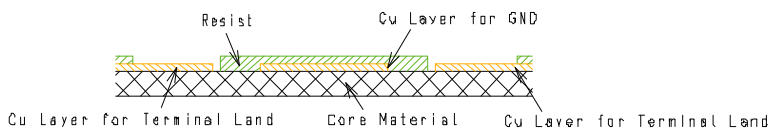

Package Outline

12 PIN XQFN (PLASTIC)

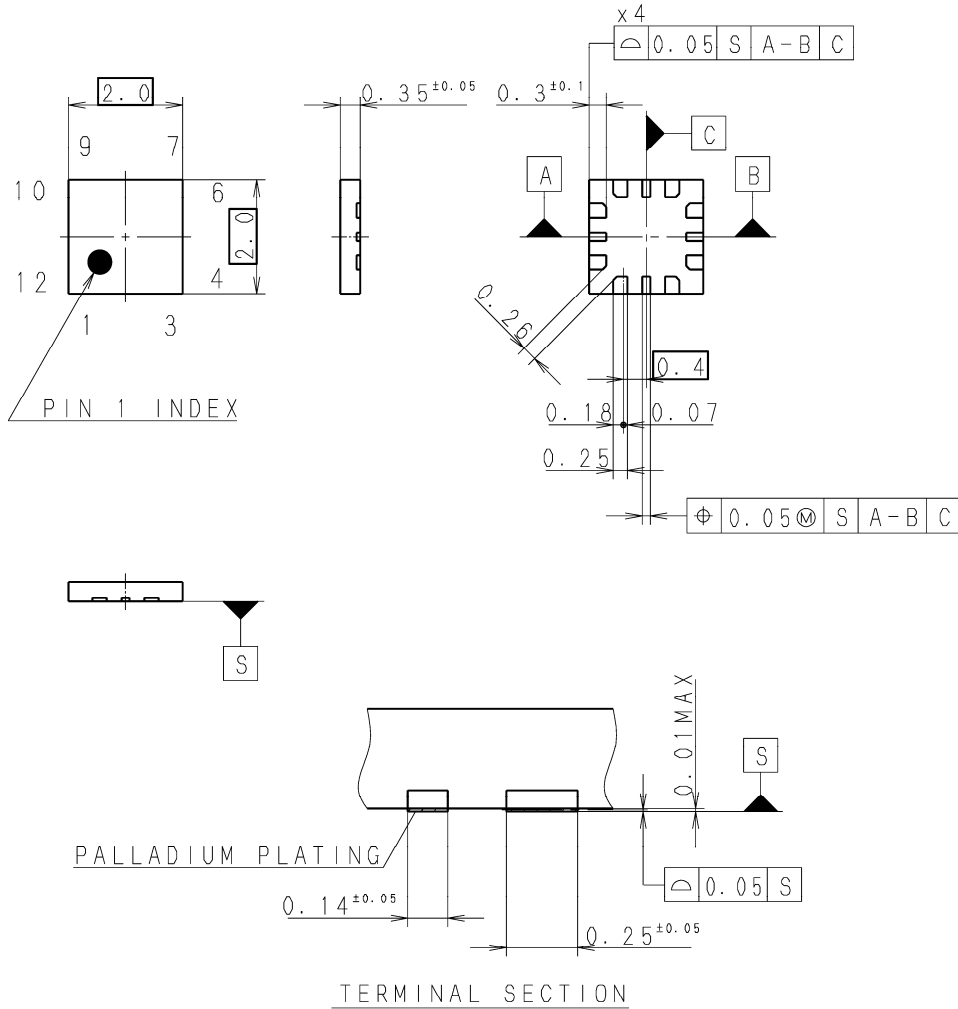

Note: Terminal burr height 0.05mm MAX.

PACKAGE STRUCTURE

SONY CODE	XQFN-12P-02
JEITA CODE	_____
JEDEC CODE	_____

PACKAGE MATERIAL	EPOXY RESIN
LEAD TREATMENT	PALLADIUM PLATING
LEAD MATERIAL	COPPER ALLOY
PACKAGE MASS	0.004g

PART No. AP-4000-12013S	
ISSUED / 11.08.30	REVISED
PRODUCTION LINE	COMPILING DIV. SDT ENGINEERING DIVISION
REMARKS PKG CODE: XR-012-D	

Marking

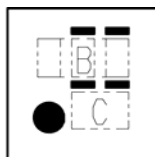

MARKING C: G9

注1) B部はロット番号 (Max 3文字で通し記号) を配置する。
(規定文字数未満につき省略は省略規定に従う。

製造年は下記2進法ビット方式により表示する。)

a 部年コード (2進法ビット方式の1ビット目を表示) を配置する。

b 部年コード (2進法ビット方式の2ビット目を表示) を配置する。

c 部年コード (2進法ビット方式の3ビット目を表示) を配置する。

d 部年コード (2進法ビット方式の4ビット目を表示) を配置する。

注2) C部は製品名 (Max 2文字) を配置する。
(2文字を超える場合は製品名省略標示規定に従う。)

注3) マーク深さは, Max 0.05mmの事。

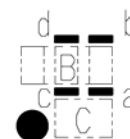

DETAIL B

< INSTRUCTIONS >

1) LOT NO. (MAX 3 CHARACTERS : SERIAL CODE) IN SECTION B.

(FOLLOW RULES FOR ABBREVIATIONS.

MANUFACTURING YEAR IS DISPLAYED BY FOLLOWING BYNARY BIT SYSTEM.)

A YEAR CODE(THE 1ST BIT OF A BINARY SYSTEM BIT SYSTEM IS DISPLAYED IN 1 DOT) IN SECTION a.

A YEAR CODE(THE 2ND BIT OF A BINARY SYSTEM BIT SYSTEM IS DISPLAYED IN 1 DOT) IN SECTION b.

A YEAR CODE(THE 3RD BIT OF A BINARY SYSTEM BIT SYSTEM IS DISPLAYED IN 1 DOT) IN SECTION c.

A YEAR CODE(THE 4TH BIT OF A BINARY SYSTEM BIT SYSTEM IS DISPLAYED IN 1 DOT) IN SECTION d.

2) TYPE NO. (MAX 2 CHARACTERS) IN SECTION C.

(FOR MORE THAN 2 CHARACTERS FOLLOW RULES FOR ABBREVIATIONS.)

3) MARK DEPTH MAX 0.05 mm.

Note

Sony reserves the right to change products and specifications without prior notice.

This information does not convey any license by any implication or otherwise under any patents or other right.

Application circuits shown, if any, are typical examples illustrating the operation of the devices. Sony cannot assume responsibility for any problems arising out of the use of these circuits.