Description

The CXA3834M is an LED driver IC with boost DC-DC converter. It enables luminance control using the peak current and PWM signal, and blinking control using the BLINK signal. This IC has an optimum configuration for realizing a simple and compact power supply circuit for an LCD TV equipped with a LED backlight. (Applications: Power supply circuit, etc.)

Features

- ◆ Shared
 - ◆ UVLO function
 - ◆ Overheat protection function
 - ◆ Error detection output function (xBL_ERR)
 - ◆ Detection timer latch function when abnormalities occur
- ◆ LED driver control block
 - ◆ On-chip LED lighting FET gate driver
 - ◆ Luminance adjustment function using peak current control
 - ◆ Luminance adjustment function using the PWM signal
 - ◆ Blinking control using the BLINK signal
 - ◆ LED overcurrent detection function
- ◆ DC-DC converter control block
 - ◆ On-chip boost type DC-DC converter
 - ◆ Output overvoltage detection function
 - ◆ Continuous overcurrent detection function
 - ◆ Input current BLINK soft start/soft end function (for blinking control operation)
 - ◆ Slope compensation function

Structure

BiCMOS silicon monolithic IC

Package

16P-SOP

Sony reserves the right to change products and specifications without prior notice. This information does not convey any license by any implication or otherwise under any patents or other right. Application circuits shown, if any, are typical examples illustrating the operation of the devices. Sony cannot assume responsibility for any problems arising out of the use of these circuits.

Absolute Maximum Ratings

Item	Symbol	Rating	Unit	Remarks
Maximum supply voltage	V _{CC_MAX}	+24.0	V	V _{CC}
xBL_ERR pin voltage	V _{xBL_ERR}	-0.3 to +24.0	V	xBL_ERR
I/O pin voltage 1	V _{IO1}	-0.3 to V _{CC} + 0.3	V	DRV, DIM_SW, PWM_DIM, BLINK, DC_DIM, EN
VREF pin voltage	V _{REF}	-0.3 to +7.0	V	VREF
I/O pin voltage 2	V _{IO2}	-0.3 to V _{REF} + 0.3	V	ISENSE, OCP, COMP, FB, PROTECT, OVP_DD
Allowable power dissipation	P _D	*1	mW	Allowable power dissipation reduction characteristics
Operating ambient temperature	T _a	-30 to +85	°C	
Junction temperature	T _{J_max}	+150	°C	
Storage temperature range	T _{stg}	-55 to +150	°C	

*1 Allowable power dissipation reduction characteristics

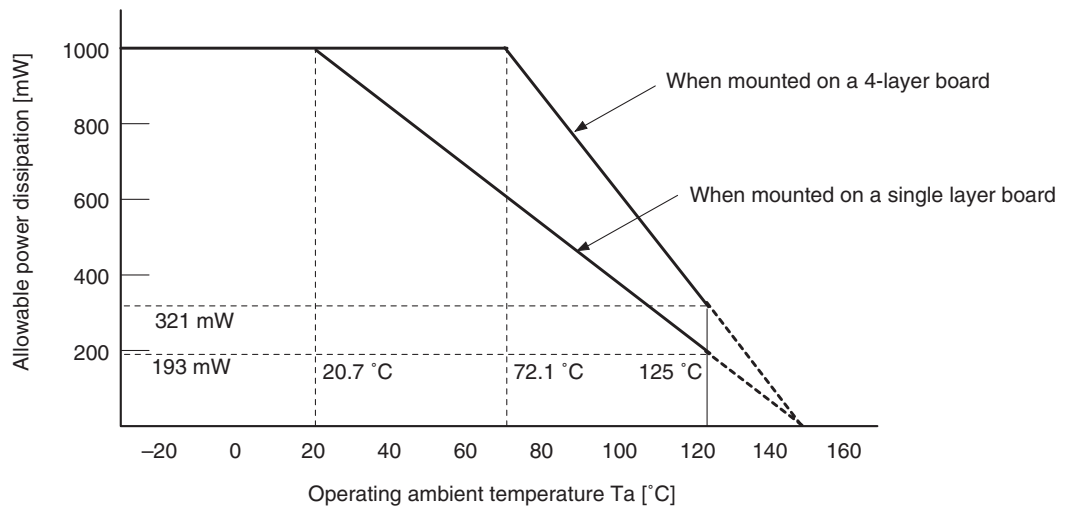

Glass fabric base epoxy board 76 mm × 114 mm t = 1.6 mm

Recommended Operating Conditions

Item	Symbol	Rating	Unit	Remarks
Supply voltage range	V _{CC}	10.0 to 18.0	V	
DC_DIM pin input voltage	V _{DC_DIM}	0.3 to 3.3	V	
PWM_DIM pin input frequency	F _{PWM_DIM}	20 to 40	kHz	Rated input frequency > 1 kHz
PWM_DIM pin minimum pulse width	T _{PWM_DIM}	1.0	μs	
BLINK pin input frequency	F _{BLINK}	48 to 240	Hz	
BLINK pin input minimum pulse width	T _{BLINK}	2.0	ms	

Pin Assignment

Block Diagram

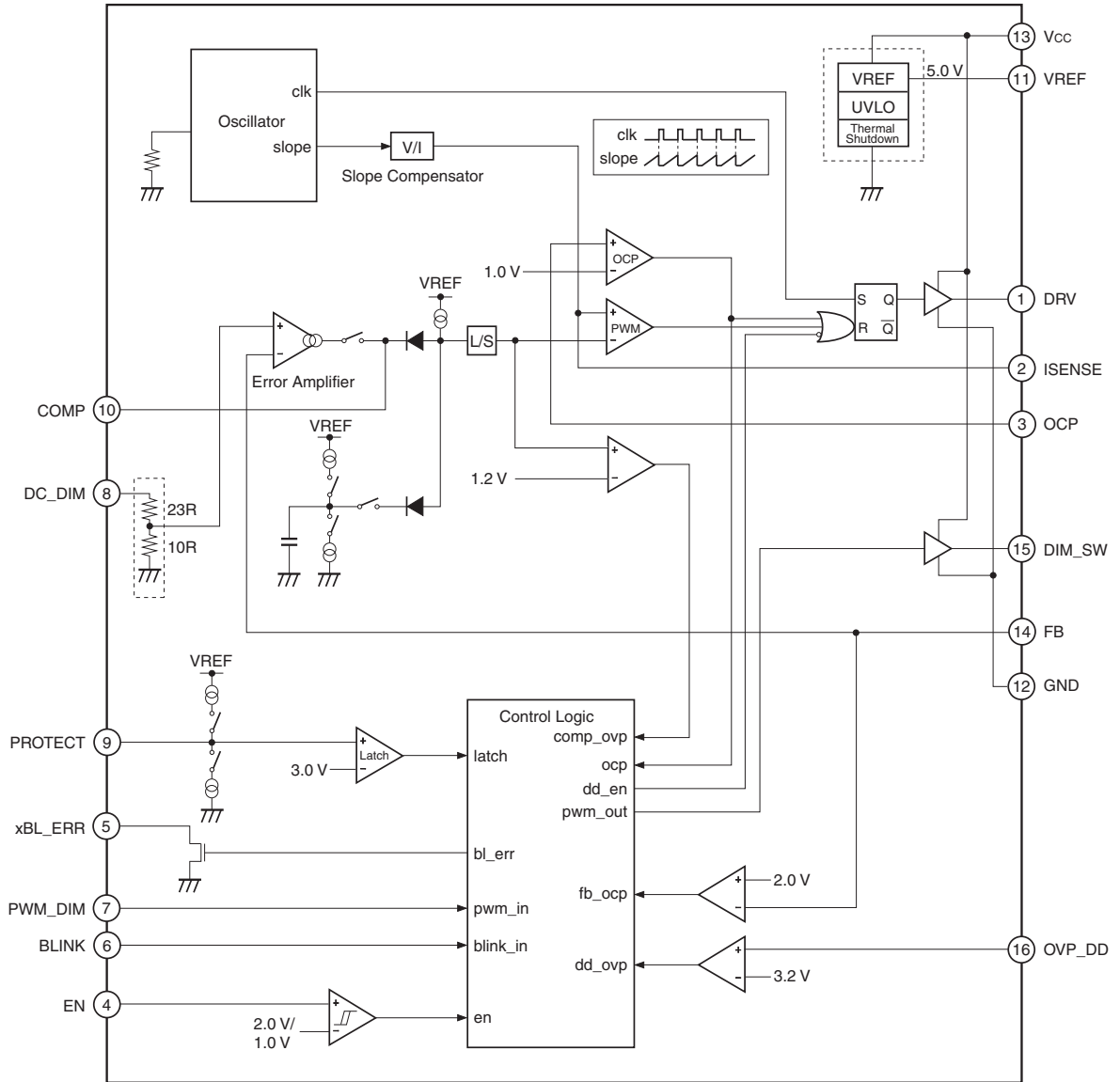

Pin Assignment

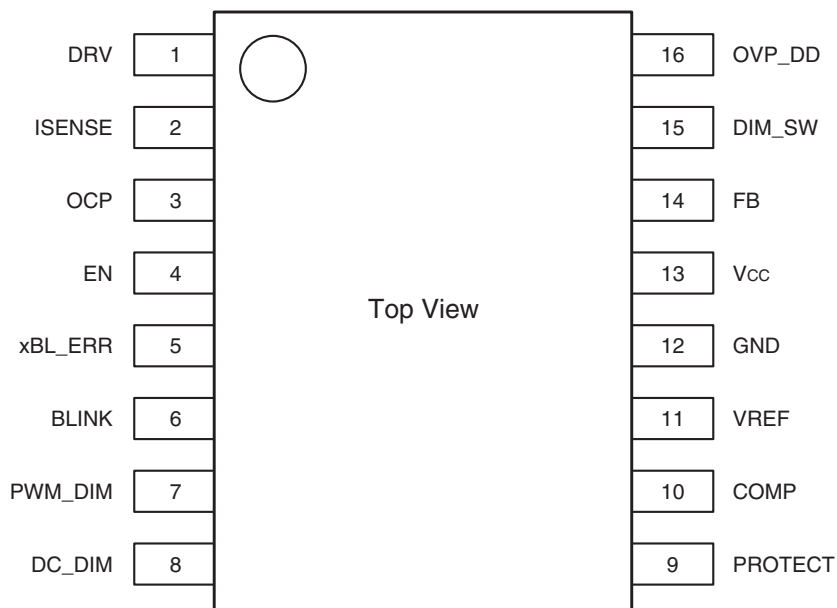

Pin Table

Pin No.	Symbol	Description	Protective element connection destination
1	DRV	MOSFET driver output for boost converter	—
2	ISENSE	Current detection input for boost converter	VREF, GND
3	OCP	Overcurrent detection input for boost converter	VREF, GND
4	EN	Enable signal input	Vcc, GND
5	xBL_ERR	Error signal output	—
6	BLINK	Blinking signal input	Vcc, GND
7	PWM_DIM	PWM dimming signal input	Vcc, GND
8	DC_DIM	Control voltage input	Vcc, GND
9	PROTECT	Protection stop timer time adjustment	VREF, GND
10	COMP	Error amplifier output for boost converter control	VREF, GND
11	VREF	Reference voltage output	Vcc, GND
12	GND	GND	—
13	Vcc	Power supply input	GND
14	FB	LED current detection input	VREF, GND
15	DIM_SW	PWM dimming MOSFET driver output	—
16	OVP_DD	Boost converter output voltage detection input	VREF, GND

Pin Description

Pin No.	Symbol	I/O	Typical pin voltage	Equivalent circuit	Description
1	DRV	O	V _{CC} to GND		MOSFET driver output for boost converter (Connect to the boost converter NMOS gate.)
2	ISENSE	I/O	1.0 V to GND		Current detection input for boost converter (Connect to a slope compensation resistor.)
3	OCP	I	1.0 V to GND		Overcurrent detection input for boost converter (Connect to a current detection resistor.)
4	EN	I	V _{CC} to GND		Enable signal input
5	xBL_ERR	I/O	V _{CC} to GND		Error signal output (Connect to a pull-up resistor.)

Pin No.	Symbol	I/O	Typical pin voltage	Equivalent circuit	Description
6	BLINK	I	3.3 V to GND		Blinking signal input
7	PWM_DIM	I	3.3 V to GND		PWM dimming signal input
8	DC_DIM	I	3.3 V to GND		Control voltage input (Connect to the R-C filter output side.)
9	PROTECT	I/O	3.0 V to GND		Protection stop timer time adjustment (Connect to the timer adjusting capacitor.)
10	COMP	I/O	3.8 V to GND		Error amplifier output for boost converter control (Connect the phase compensation circuit between COMP and GND.)

Pin No.	Symbol	I/O	Typical pin voltage	Equivalent circuit	Description
11	VREF	O	5.0 V		Internal supply voltage output (Connect a stabilizing capacitor.)
12	GND				GND
13	Vcc				Power supply input (Connect a stabilizing capacitor.)
14	FB	I	1.0 V to GND		LED current detection input (Connect to a current detection resistor.)
15	DIM_SW	O	Vcc to GND		MOSFET driver output for PWM dimming (Connect to the dimming NMOS gate.)
16	OVP_DD	I	3.2 V to GND		Output voltage detection input for boost converter (Connect to an output voltage detection resistor.)

Electrical Characteristics

◆ Shared Blocks

(Unless otherwise specified, Ta = 25 °C, Vcc = 12 V, EN = 3.3 V, PWM_DIM = 3.3 V, BLINK = 3.3 V, DC_DIM = 3.3 V)

Power Supply Block (Vcc pin)

Item	Symbol	Measurement conditions	Min.	Typ.	Max.	Unit
Operation start voltage	V _{CC_ON}		9.0	9.5	10.0	V
Operation stop voltage	V _{CC_OFF}		8.5	9.0	9.5	V
Hysteresis width	ΔV _{CC}	V _{CC_ON} – V _{CC_OFF}	0.3	0.5	0.7	V
Operating current consumption	I _{CC1}	FB = 1.5 V * Non switching	—	1.15	1.65	mA
Current consumption when stopped	I _{CC2}	EN = 0 V	—	0.85	1.10	mA

Reference Voltage Block (VREF pin)

Item	Symbol	Measurement conditions	Min.	Typ.	Max.	Unit
Output voltage	V _{REF}		4.85	5.00	5.15	V
Input stability	V _{REF_LINE}	V _{CC} = 10.0 V to 18.0 V, No load	—	10	50	mV
Load stability	V _{REF_LOAD}	I _{out} = 0.1 m to 5.0 mA	—	20	50	mV

Enable Signal Input Block (EN pin)

Item	Symbol	Measurement conditions	Min.	Typ.	Max.	Unit
High level detection voltage	V _{EN_H}		1.9	2.0	2.1	V
Low level detection voltage	V _{EN_L}		0.9	1.0	1.1	V
Hysteresis width	ΔV _{EN}	V _{EN_H} – V _{EN_L}	0.9	1.0	1.1	V
Pin input resistance	R _{EN}	EN = 1.0 V	200	300	400	kΩ

Error Output Block (xBL_ERR pin)

Item	Symbol	Measurement conditions	Min.	Typ.	Max.	Unit
Output Low voltage	V _{xBL_ERR_L}	EN = 0 V, I _{out} = –3 mA	—	0.15	0.3	V
Output off leak current	I _{xBL_ERR_OFF}	xBL_ERR = 18 V	—	—	1.0	μA

Protective Detection Pin (PROTECT pin)

Item	Symbol	Measurement conditions	Min.	Typ.	Max.	Unit
Latch stop detection voltage	V _{PROTECT}		2.9	3.0	3.1	V
Charge current	I _{PROTECT_CHG}	PROTECT = 1.0 V, PWM_DIM = 12.0 V	8.0	10.0	12.0	μA
Discharge current	I _{PROTECT_RST}	PROTECT = 1.0 V	0.8	1.0	1.2	μA

◆ LED Driver Control Block

(Unless otherwise specified, $T_a = 25\text{ }^\circ\text{C}$, $V_{CC} = 12\text{ V}$, $EN = 3.3\text{ V}$, $PWM_DIM = 3.3\text{ V}$, $BLINK = 3.3\text{ V}$, $DC_DIM = 3.3\text{ V}$)**MOSFET Driver Output Block (DIM_SW pin)**

Item	Symbol	Measurement conditions	Min.	Typ.	Max.	Unit
Output rise time *1	TR_DIM_SW	CLOAD = 1000 pF	—	30	60	ns
Output fall time *1	TF_DIM_SW	CLOAD = 1000 pF	—	30	60	ns
Output High voltage	V _{DIM_SW_H}	I _{out} = 10 mA	11.90	11.95	—	V
Output Low voltage	V _{DIM_SW_L}	PWM_DIM = 0 V, I _{out} = -10 mA	—	0.05	0.1	V

*1 Rise time and fall time use $V_{CC} \times 0.1$ to $V_{CC} \times 0.9$ as the judgment voltages.**Error Amplifier Input Circuit Block (FB pin, DC_DIM pin)**

Item	Symbol	Measurement conditions	Min.	Typ.	Max.	Unit
Feedback control voltage 1	V _{FB_REF1}	DC_DIM = 3.3 V	0.98	1.00	1.02	V
Feedback control voltage 2	V _{FB_REF2}	DC_DIM = 1.65 V	0.495	0.500	0.505	V
FB pin pull-up current	I _{FB}	FB = 0.1 V	0.05	0.1	0.2	μA
Overcurrent detection voltage	V _{FB_OCP}		1.9	2.0	2.1	V
DC_DIM pin input resistance	R _{DC_DIM}	DC_DIM = 1.0 V	700	990	1300	kΩ

PWM Dimming Signal Input Block (PWM_DIM pin)

Item	Symbol	Measurement conditions	Min.	Typ.	Max.	Unit
High level input voltage	V _{PWM_DIM_H}		2.0	—	$V_{CC} - 2.0$	V
Low level input voltage	V _{PWM_DIM_L}		—	—	1.0	V
Pin input resistance	R _{PWM_DIM}	PWM_DIM = 1.0 V	200	300	400	kΩ

BLINK Signal Input Block (BLINK pin)

Item	Symbol	Measurement conditions	Min.	Typ.	Max.	Unit
High level input voltage	V _{BLINK_H}		2.0	—	$V_{CC} - 2.0$	V
Low level input voltage	V _{BLINK_L}		—	—	1.0	V
Pin input resistance	R _{BLINK}	BLINK = 1.0 V	200	300	400	kΩ

◆ DC-DC Converter Control Block

(Unless otherwise specified, Ta = 25 °C, Vcc = 12 V, EN = 3.3 V, PWM_DIM = 3.3 V, BLINK = 3.3 V, DC_DIM = 3.3 V)

MOSFET Driver Output Block (DRV pin)

Item	Symbol	Measurement conditions	Min.	Typ.	Max.	Unit
Output rise time *1	TR_DRV	CLOAD = 1000 pF	—	35	70	ns
Output fall time *1	TF_DRV	CLOAD = 1000 pF	—	25	50	ns
Output High voltage	VDRV_H	Iout = 10 mA (Design guarantee)	11.85	11.90	—	V
Output Low voltage	VDRV_L	EN = 0 V, Iout = -10 mA	—	0.03	0.1	V
Oscillation frequency	FOSC	ISENSE = 0 V, OCP = 0 V, FB = 0 V	95	100	105	kHz
Maximum On duty	DMAX	ISENSE = 0 V, OCP = 0 V, FB = 0 V	85	90	95	%

*1 Rise time and fall time use $V_{cc} \times 0.1$ to $V_{cc} \times 0.9$ as the judgment voltages.

Error Amplifier Output Block (COMP pin)

Item	Symbol	Measurement conditions	Min.	Typ.	Max.	Unit
Transconductance	gm	(Design guarantee)	—	520	—	$\mu A/V$
Output source current	ICOMP_H	FB = 0 V, COMP = 3.0 V	60	80	100	μA
Output sink current	ICOMP_L	FB = 1.5 V, COMP = 0.5 V	60	80	100	μA
BLINK soft start time	TSS	COMP = 1.8 V (Design guarantee)	320	400	480	μs
BLINK soft end time	TSE	COMP = 1.8 V (Design guarantee)	320	400	480	μs

Current Detection Circuit Block (ISENSE pin)

Item	Symbol	Measurement conditions	Min.	Typ.	Max.	Unit
Slope compensation output current	ISLOPE	FB = 0 V, OPC = 0 V (Peak current value during maximum ON duty operation) (Design guarantee)	—	50	—	μA

Overcurrent Detection Block (OCP pin)

Item	Symbol	Measurement conditions	Min.	Typ.	Max.	Unit
Overcurrent limit detection voltage	VOCP	FB = 0 V, ISENSE = 0 V	0.9	1.0	1.1	V
DD blanking pulse width	TDD_BLK	OCP = 1.5 V, FB = 0 V	350	500	650	ns
OCP pin pull-up current	IOCP	OCP = 0.1 V	0.05	0.1	0.2	μA

Output Voltage Detection Block (OVP_DD pin)

Item	Symbol	Measurement conditions	Min.	Typ.	Max.	Unit
Output overvoltage detection voltage	VOVP		3.1	3.2	3.3	V
OVP_DD pin pull-up current	IOVP	OVP_DD = 0.1 V	0.05	0.1	0.2	μA

Note) Shipping inspection is performed at room temperature. (The design is guaranteed with respect to temperature fluctuation.)

Detailed Description of Blocks

Start-up/Stop

CXA3834M operation starts when voltage of 9.5 V (typ.) or more is applied to the Vcc pin. When this voltage is applied to the Vcc pin, the internally generated reference voltage (VREF pin) is generated and the reset state (POR) is canceled.

In addition, Vcc has a built-in UVLO function, and when the Vcc pin voltage falls to 9.0 V (typ.) or less, the IC enters the reset state, the DC-DC converter stops operation and the DIM_SW output goes to Low output regardless of the input signals of other pins.

When the Vcc pin voltage rises to 9.5 V or more again, the reset is canceled and stopped functions can be operated.

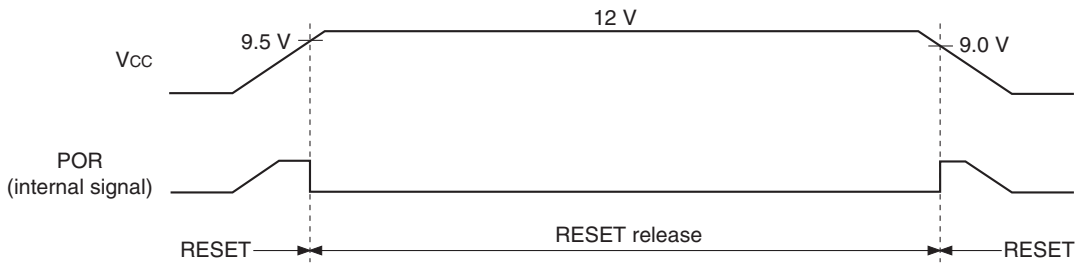

Fig. 1. Start-up and Stop Operation After Power-on

Enable (EN)

DC-DC converter and LED driver operations are enabled by setting the EN pin to 2.0 V or more.

In addition, the PWM_DIM pin and the BLINK pin must both be High for the DC-DC converter to start operation. When the EN pin falls to 1.0 V or less, the DC-DC converter stops operating instantly, but the signal input to the PWM_DIM pin is output on the DIM_SW pin. In addition, when the EN pin is Low, the signal input to the PWM_DIM pin is output as is on the DIM_SW pin even when the BLINK pin is Low.

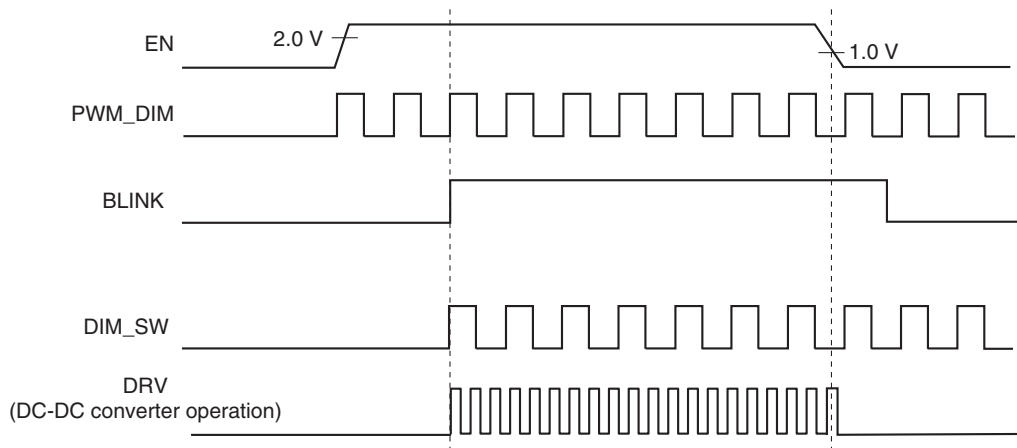

Fig. 2. Operation During Voltage Input to the EN Pin

Dimming Control Block

The CXA3834M has an on-chip constant current mode boost DC-DC converter to generate the voltage required to light the LED elements. The voltage (VOUT) boosted by the DC-DC converter is applied to the anode side of the multiple LED elements connected in series, and when a High voltage is input to the PWM_DIM pin, the DIM_SW pin also outputs a High voltage, the external FET is driven, and current flows to the LED elements.

Fig. 3 shows a schematic of the operating circuit.

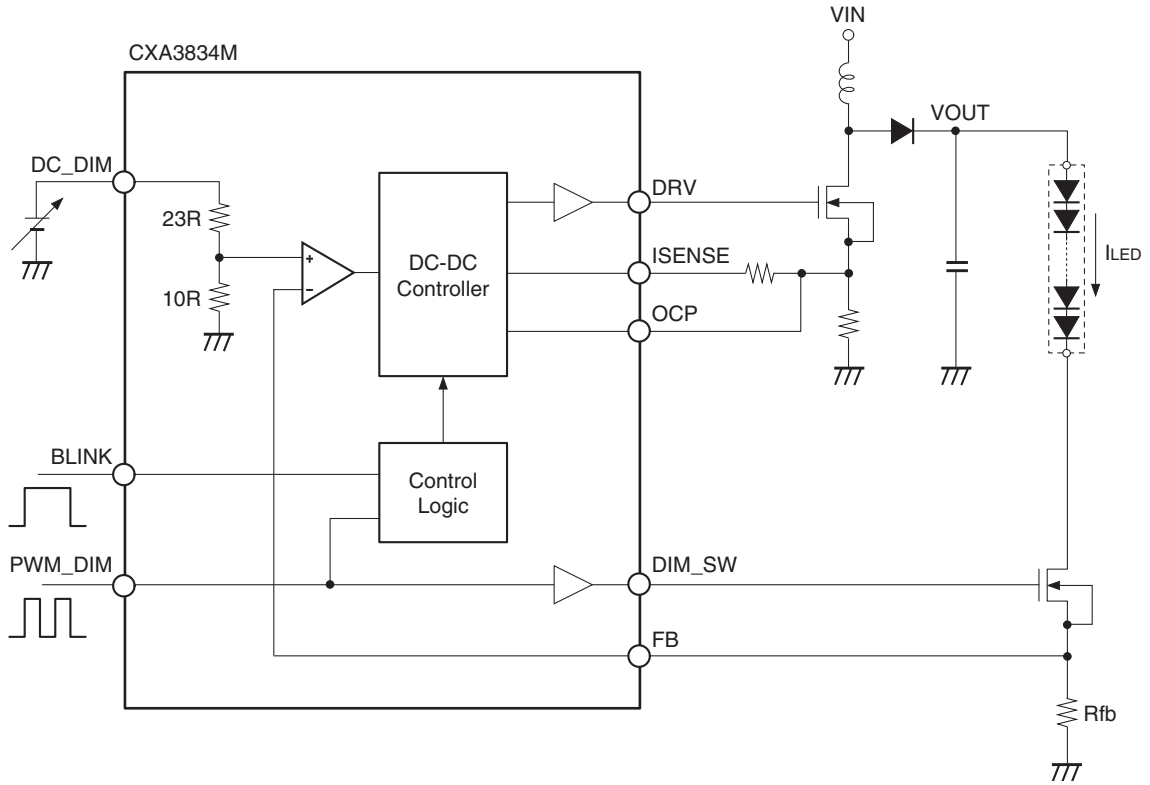

Fig. 3. CXA3834M Operating Circuit Diagram

LED Luminance Adjustment

The CXA3834M can adjust the LED luminance using two different settings.

[Luminance Adjustment by PWM Control]

The pulse input to the PWM_DIM pin is output on the DIM_SW pin. The external FET gate is driven and current flows to the LED elements in accordance with the DIM_SW pin output. The average current flowing to the LED elements is proportional to the duty of the pulse input to the PWM_DIM pin, so the LED element luminance can be adjusted by controlling the duty. (See Fig. 4.)

Use a CXA3834M PWM_DIM pin input pulse with a frequency between 20 kHz and 40 kHz with a minimum High pulse width of 1 μs.

[Luminance Adjustment by Peak Current Control]

The current flowing to the LED elements is converted to a voltage by the FB resistor (Rfb), and this voltage monitored by the FB pin of the CXA3834M. The DC-DC converter compares the FB pin voltage with the value 10/33 times the DC_DIM pin voltage (V_{DC_DIM}), and controls the output voltage (V_{OUT}) to hold the same potential. That is to say, the current flowing to the LED elements or the FB pin resistor can be controlled by controlling the DC_DIM pin voltage. The current flowing to the LED elements is determined by the following formula.

$$I_{LED} = \left(V_{DC_DIM} \times \frac{10}{33} \right) / R_{fb} [A]$$

Fig. 5 shows the relationship between the DC_DIM pin voltage and FB pin resistance value and the current flowing to the LED elements.

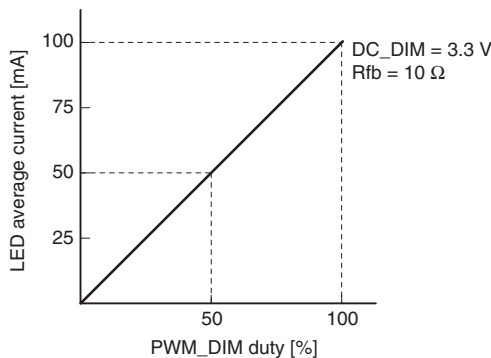

Fig. 4. PWM_DIM_Duty - ILED Characteristics

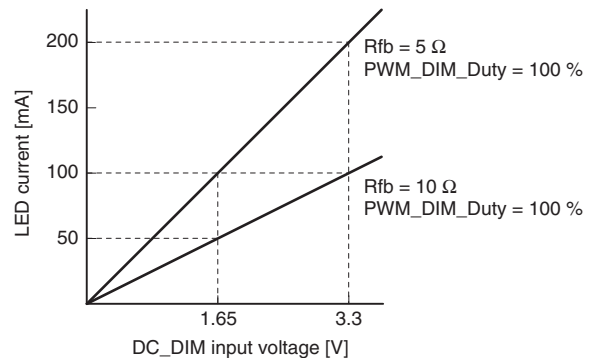

Fig. 5. DC_DIM Voltage - ILED Characteristics

The DC_DIM pin is pulled down internally by resistance of 990 kΩ (typ.). When connecting a smoothing RC filter to the DC_DIM pin, determine the constants in consideration of the IC internal impedance.

LED Blinking Control (Blinking)

The CXA3834M has a BLINK pin, and the LED elements can be made to perform blinking operation by switching the signal input to the BLINK pin between High and Low. When the BLINK signal is Low, the DIM_SW pin is forcibly set to Low output (LED elements off), and at the same time the DC-DC converter output voltage ripple is suppressed, so DC-DC converter boost operation (DRV output) is also forcibly stopped. Fig. 6 shows operation relative to the signal input to the BLINK pin.

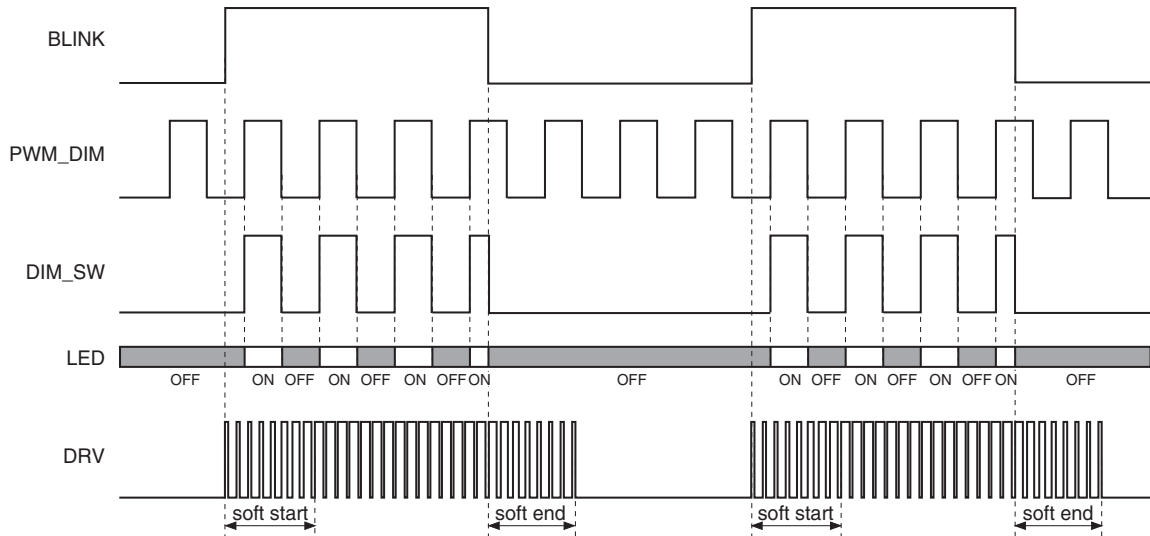

Fig. 6. Timing Chart During Blinking Operation

Use a CXA3834M BLINK pin input pulse with a maximum frequency of 240 Hz with a minimum High pulse width of 2 ms.

The soft start/soft end function during blinking operation is described hereafter.

For applications that do not perform blinking operation, connect the BLINK pin to the VREF pin.

LED Overcurrent Detection Circuit Block

The CXA3834M has an overcurrent detection function to detect abnormalities in the current flowing to the LED elements. Fig. 7 shows the FB pin peripheral equivalent circuit.

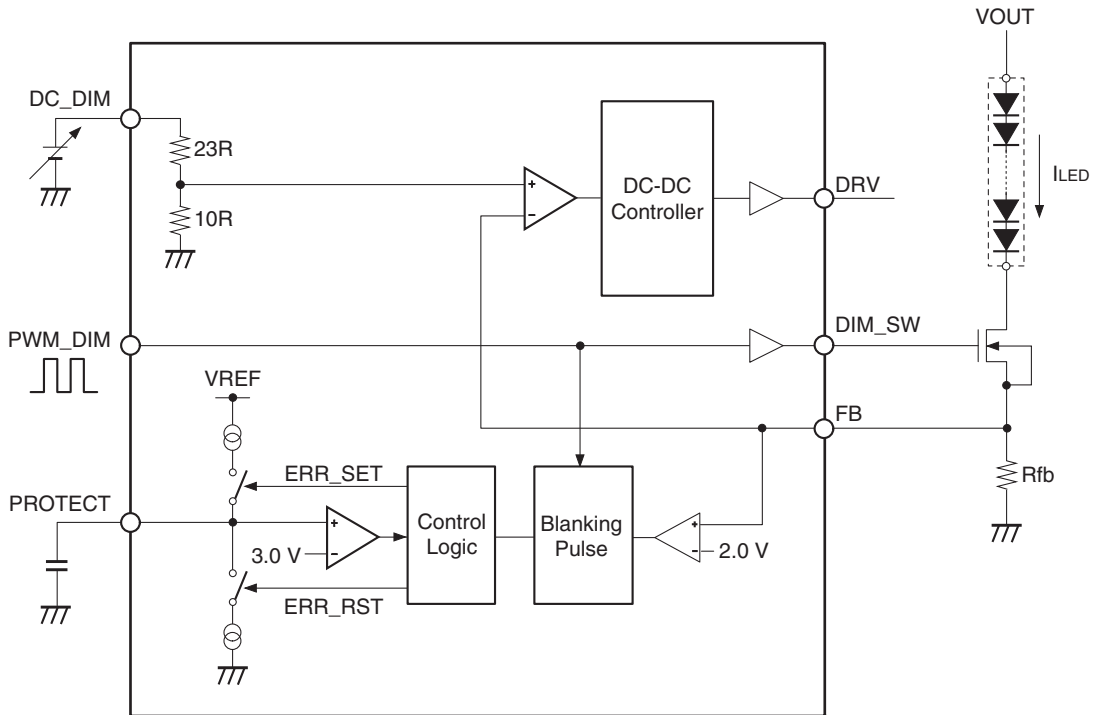

Fig. 7. FB Pin Peripheral Equivalent Circuit

When a FB pin voltage of 2.0 V (typ.) or more is detected (LED_OCP), charging to the PROTECT pin starts (charge current: 10 μ A (typ.)). LED_OCP is detected continuously, and when the PROTECT pin voltage reaches 3 V, the IC is set to stop mode (latch stop). Charging to the PROTECT pin is performed only while LED_OCP is detected. When LED_OCP is not detected, the PROTECT pin discharges at 1 μ A (typ.). This IC generates a blanking pulse to prevent the above-mentioned overcurrent detection from malfunctioning. This blanking pulse is approximately 500 ns (min.), and prevents false overcurrent detection due to the inrush current that occurs when DIM_SW switches from Low to High. The FB pin voltage is controlled by 10/33 times the DC_DIM pin voltage, but note that overcurrent is detected more easily when the DC_DIM pin voltage is set too high.

Fig. 8 shows the timing chart during LED_OCP operation.

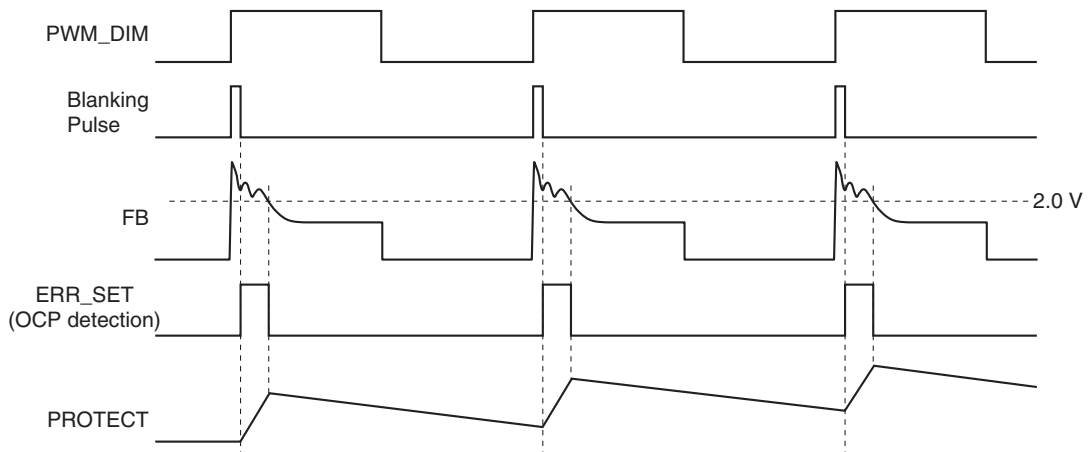

Fig. 8. LED_OCP Detection Timing Chart

DC-DC Converter Control Block

Oscillator Circuit Block

The CXA3834M DC-DC converter oscillating frequency is fixed to 100 kHz (typ.) by the internal circuit. The maximum ON duty is 90 % (typ.), and the boost converter MOSFET ON time is normally proportional to the COMP pin voltage. Fig. 9 shows the oscillator peripheral equivalent circuit.

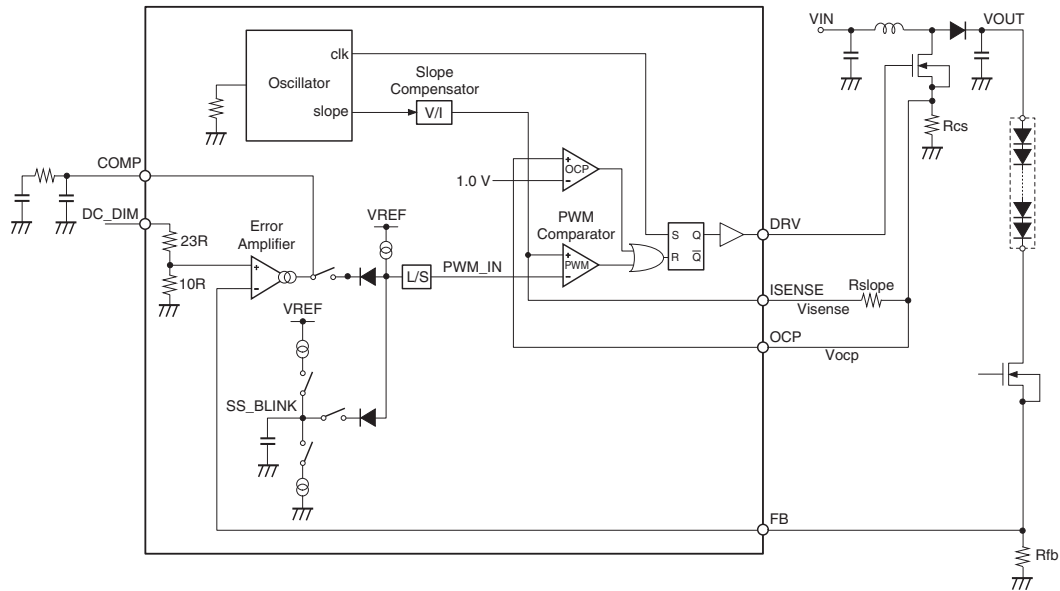

Fig. 9. Oscillator Peripheral Equivalent Circuit

[Steady-state Operation]

When the CLK pulse is output from the oscillator, the DRV pin output goes High and current starts to flow to the choke coil. The current that flows to the choke coil is converted to a voltage (Vocp) by the current detection resistor (Rcs). The ISENSE pin voltage (Visense) is the sum of Vocp and the voltage generated by the internal slope compensation current flowing to the slope compensation resistor (Rslope), and is input to the PWM comparator non-inverted input pin. When Visense rises to the PWM comparator inverted input pin (PWM_IN) voltage or more, the reset signal is generated and the DRV pin output goes Low. The PWM_IN voltage (Vpwm_in) is the voltage obtained by level-shifting the COMP pin voltage (Vcomp), and is determined approximately by the following calculation formula. Here, Vt corresponds to the internal transistor threshold voltage, and is approximately 0.8 V in the CXA3834M.

$$V_{pwm_in} = (V_{comp} - V_t) \times 3/5$$

When the current flowing to the choke coil is low and Visense does not reach the PWM_IN voltage during one cycle period, the DRV output automatically goes Low when the ON duty reaches 90 % (typ.). The above operation is repeated and boost operation is continued until the prescribed current flows to the LED elements.

Fig. 10 shows the DC-DC converter operation timing chart during steady-state operation.

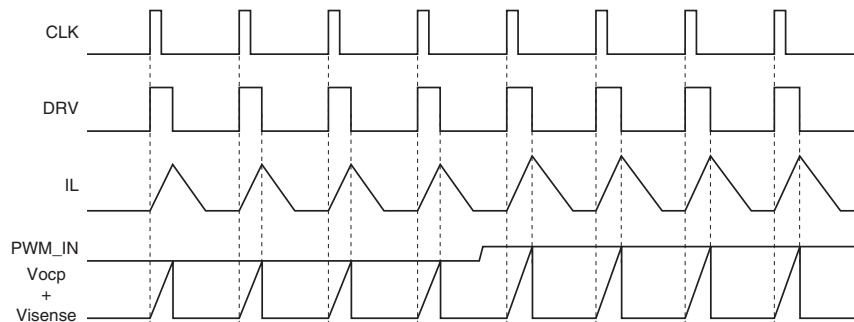

Fig. 10. DC-DC Converter Operation Timing Chart

[Overcurrent Detection]

The peak current flowing to the choke coil is constantly monitored by the OCP pin, and when the OCP pin voltage reaches 1.0 V (typ.), the DRV pin output is forcibly set Low (pulse-by-pulse operation). After overcurrent detection, the PROTECT pin is charged at 10 μ A (typ.) until the next cycle starts.

When overcurrent is detected continuously, the PROTECT pin is continuously charged, and when the PROTECT pin voltage reaches 3 V, the IC latch stops.

The CXA3834M generates a blanking pulse to prevent false OCP pin overcurrent detection.

This blanking pulse is 500 ns (typ.), and prevents false overcurrent detection due to the inrush current that occurs when the DRV pin output switches from Low to High.

[Slope Compensation]

When the constant current mode boost converter is set so that the DRV pin ON duty is 50 % or more, sub-harmonic oscillation may occur. The CXA3834M can operate the boost converter stably even when the ON duty is 50 % or more by inserting a series resistor (R_{slope}) to the ISENSE pin and applying slope compensation. For details on sub-harmonic oscillation and slope compensation, see the Application Notes.

Input Current BLINK Soft Start/Soft End Control Circuit Block

The CXA3834M has a BLINK pin in consideration of LED blinking operation. When a Low signal is input to the BLINK pin, the DIM_SW pin outputs Low, the LED elements turn off, and the DC-DC converter temporarily stops operation. When a High signal is input to the BLINK pin, the DIM_SW pin outputs High, the LED elements light, and the DC-DC converter starts to operate again. However, there are concerns that sudden changes in the DC-DC converter load in accordance with BLINK pin High/Low output may cause the choke coil and other components to squeal.

The CXA3834M has a DC-DC converter BLINK soft start/soft end function that enables to reduce squealing during blinking operation. Fig. 11 gives an overview of DC-DC converter control during blinking operation.

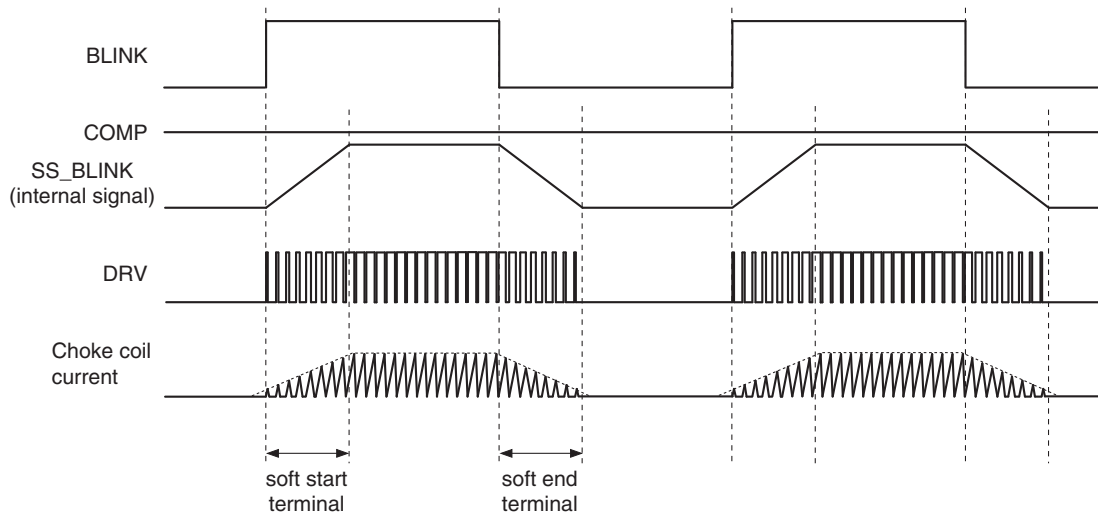

Fig. 11. Overview of DC-DC Converter Operation During Blinking

Charging to the internal SS_BLINK node starts when the BLINK pin input signal changes from Low to High. The PWM comparator inverted input voltage is proportional to the SS_BLINK node voltage, and the DRV pin output pulse width is proportional to the PWM comparator inverted input voltage. In addition, the input peak current flowing to the boost choke coil is proportional to the DRV pin pulse width, so the current waveform is as shown in Fig. 11, enabling sudden fluctuations in the input current when the BLINK pin input signal changes from Low to High to be suppressed. SS_BLINK node charging continues until the voltage reaches the COMP pin output voltage, and then the voltage after charging is complete is held until a High signal is input to the BLINK pin. When the BLINK pin voltage changes from High to Low, the SS_BLINK node voltage is discharged and the PWM comparator inverted input voltage decreases in accordance with this discharge. SS_BLINK node discharging continues until the PWM comparator inverted input voltage falls to approximately 0 V, and the DRV pin output pulse width and choke coil input peak current during that period decrease in proportion to the PWM comparator inverted input voltage.

The BLINK soft start time and BLINK soft end time are determined according to the COMP pin output voltage, and are set to approximately 400 μ s when the COMP pin voltage is 1.8 V.

COMP Pin Hold Circuit Block

The FB pin voltage temporarily goes to 0 V while a Low signal is input to the PWM_DIM pin and current is not flowing to the LED elements (DIM_SW pin output signal Low period), so the COMP pin voltage and the DC-DC converter output voltage rise temporarily. In this case, when a High signal is input to the PWM_DIM pin in the next cycle, a transient current flows to the LED elements.

In the CXA3834M, the COMP pin voltage immediately before a Low signal is input to the PWM_DIM pin is held, and DC-DC converter operation continues. By holding the COMP pin voltage, operation can be performed without a transient current flowing to the LED elements even when the PWM_DIM pin signal goes High in the next cycle. Similar operation is also performed when the BLINK pin input signal is Low, so that the COMP pin output voltage is held even when a Low signal is input to the BLINK pin and boost operation stops.

Fig. 12 and Fig. 13 show the COMP pin hold function timing chart and the COMP pin peripheral equivalent circuit, respectively.

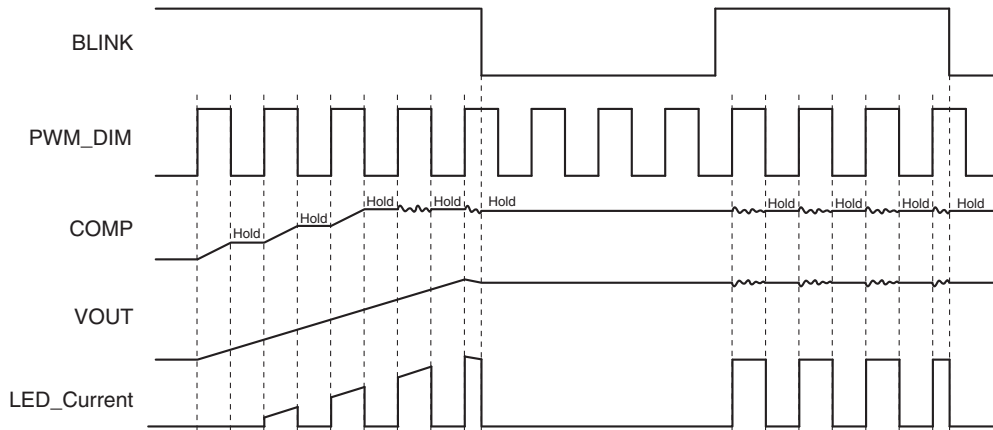

Fig. 12. COMP Pin Hold Function Timing Chart

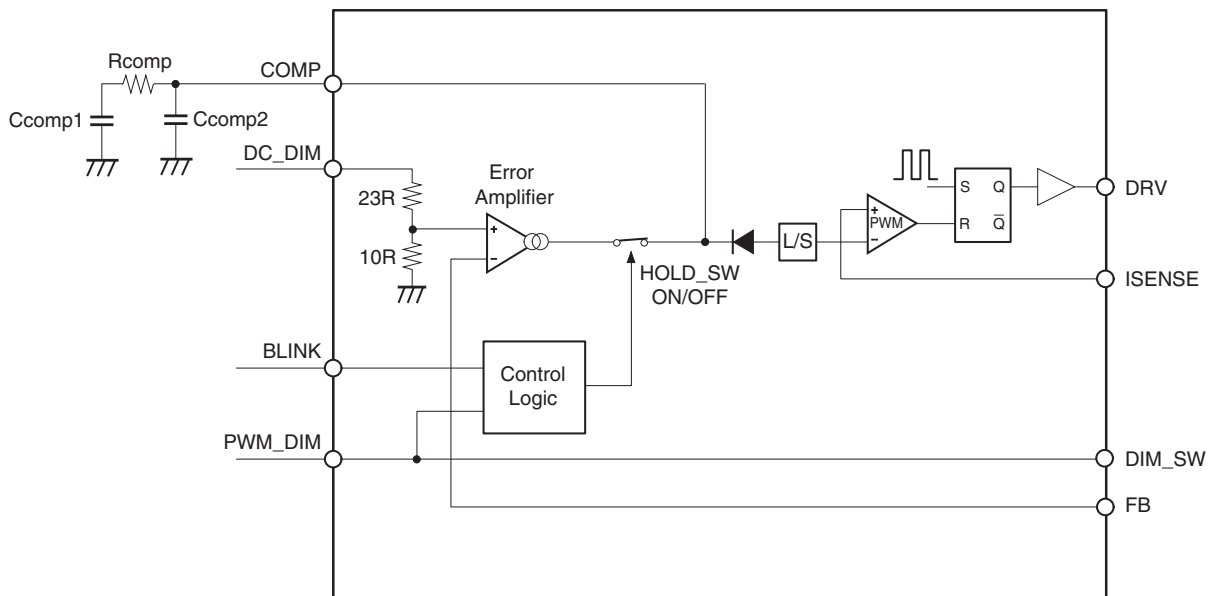

Fig. 13. COMP Pin Peripheral Equivalent Circuit

When the signal input to the PWM_DIM pin has a high frequency (up to approximately 40 kHz) and low duty, the effect of the hold function reduces the COMP pin response speed, and may influence the start-up time and the LED current characteristics. Make thorough evaluation before determining the phase compensation constants Rcomp, Ccomp1 and Ccomp2 connected to the COMP pin. For details, see the Application Notes.

Output Voltage Detection Circuit Block

Fig. 14 shows the OVP_DD pin peripheral equivalent circuit.

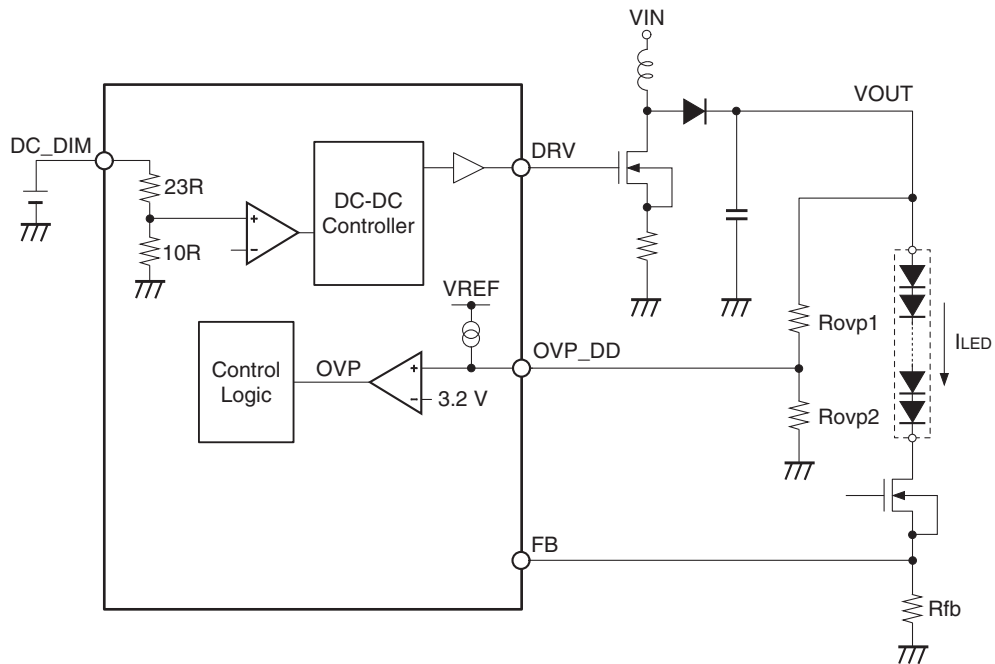

Fig. 14. OVP_DD Pin Peripheral Equivalent Circuit

The OVP_DD pin has a protective function that detects DC-DC converter output overvoltage. When an OVP_DD pin voltage of 3.2 V (typ.) or more is detected (OVP), the IC instantly latch stops. To properly light the LED elements during normal operation, set the breeder resistance ratio (R_{ovp1}/R_{ovp2}) so that the voltage input to the OVP_DD pin is 3.2 V or less.

In addition, pull-up current of 0.1 μA (typ.) is supplied from inside the IC in consideration of the case when the OVP_DD pin is open. When the OVP_DD pin is open, the pin voltage is pulled-up to approximately the VREF pin voltage, OVP is detected, and the IC latch stops. Therefore, set the R_{ovp2} resistance value to a value that does not affect this 0.1 μA current.

Protective Detection Functions

The CXA3834M has various built-in protective functions to realize stable power supply operation. When an error is detected by a protective function, the xBL_ERR pin outputs a Low signal, and either timer latch operation is performed by charging the PROTECT pin or instant latch stop operation is performed. Table 1 lists the protective functions, error conditions, and operation after detection. When the IC latch stops after an error is detected, DC-DC converter operation stops and the DIM_SW pin outputs Low. When the IC has performed latch operation (LATCH1), the latch can be canceled by turning the power supply off and then on again, or by stopping and then restarting EN supply. When latch stop operation was performed due to overheat protective detection (TSD) (LATCH2), the latch can be canceled only by turning the power supply off and then on again.

Table 1. List of Protective Functions

No.	Protective function	Detection conditions	PROTECT pin charging	xBL_ERR = Low output
Backlight error detection function (xBL_ERR = Low output)				
1	MOS_FET open detection	When the COMP pin output stays High	—	○
2	VREF overvoltage detection 1	VREF pin voltage > 6.0 V	—	○
Timer latch function (PROTECT pin charging)				
3	DC-DC overcurrent detection (DD_OCP)	OCP pin voltage > 1.0 V	○	—
4	LED overcurrent detection (LED_OCP)	FB pin voltage > 2.0 V	○	—
5	DRV pin error detection	DRV pin input/output mismatch	○	—
Backlight error detection and timer latch function				
6	PWM_DIM pin protective detection	PWM_DIM pin voltage > Vcc – 0.5 V	○	○
7	BLINK pin protective detection	BLINK pin voltage > Vcc – 0.5 V	○	○
8	DC_DIM pin protective detection	DC_DIM pin voltage > Vcc – 0.5 V	○	○
9	VREF overvoltage detection 2	VREF pin voltage > 5.5 V	○	○
Instant latch function 1 (Latch1)				
10	DC-DC output overvoltage protection (OVP)	OVP_DD pin voltage > 3.2 V	—	—
11	PROTECT latch stop detection	PROTECT pin voltage > 3.0 V	—	—
Instant latch function 2 (Latch2)				
12	Overheat detection (TSD)	Tj > 140 °C	—	—

[Backlight Error Detection Function]

When error number 1, 2, 6, 7, 8 or 9 in Table 1 is detected, the xBL_ERR pin outputs Low, and current is pulled into the IC from an external voltage source via a pull-up resistor. When a backlight error is not detected, the xBL_ERR pin is high impedance, so the external pull-up voltage source voltage is generated on the pin.

[Timer Latch Function]

When error number 3, 4, 5, 6, 7, 8 or 9 in Table 1 is detected, charging to the PROTECT pin starts, and the IC latch stops when the PROTECT pin voltage reaches 3 V. The time after an error is detected until the latch stop operation can be set by connecting a capacitor to the PROTECT pin. Fig. 15 and Fig. 16 show the PROTECT pin peripheral equivalent circuit and the error detection timing chart, respectively.

[Instant Latch Function]

When error number 10 or 11 in Table 1 is detected, the IC instantly latch stops, and DC-DC converter and dimming operation also stop. When the IC has latch stopped, the xBL_ERR pin outputs Low.

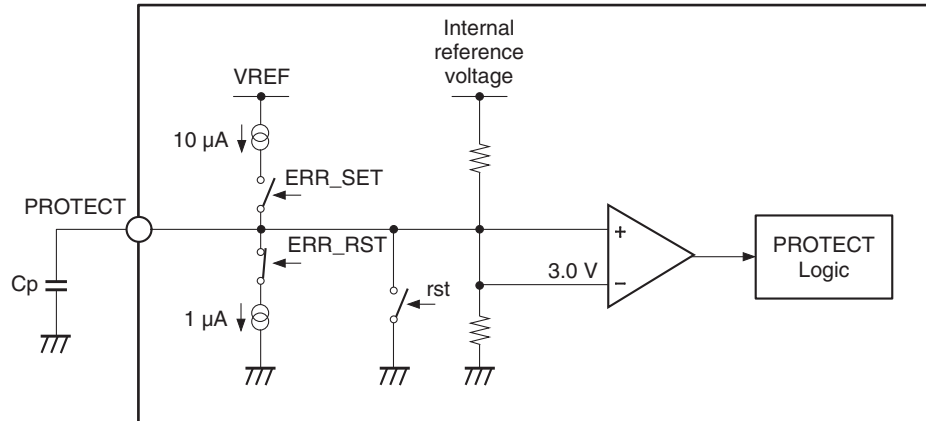

Fig. 15. PROTECT Pin Equivalent Circuit

When an error is detected (ERR_SET = High), stable current of 10 μA flows out from the IC via the PROTECT pin. During normal operation (ERR_RST = High), stable current of 1 μA flows into the IC via the PROTECT pin.

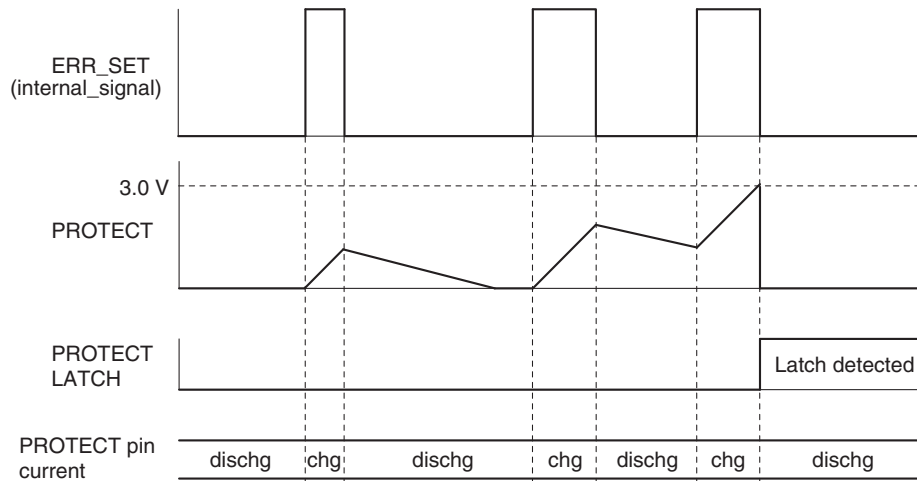

Fig. 16. Error Detection Timing Chart

The timer time when an error is continuously detected can be expressed by the following formula.

$$T = C_p (\mu\text{F}) \times 3.0 \text{ V} / 10 \mu\text{A} = 0.3 \times C_p (\text{s})$$

[State Transition Diagram]

Fig. 17 shows the state transitions of this IC.

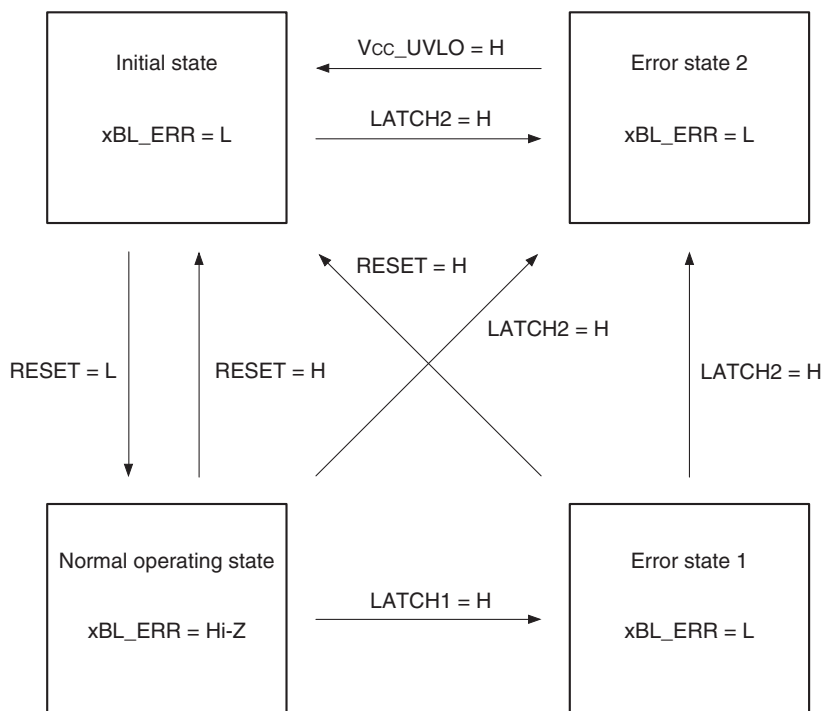
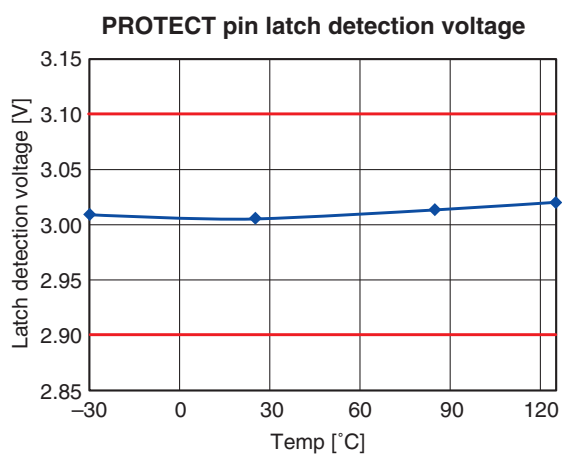
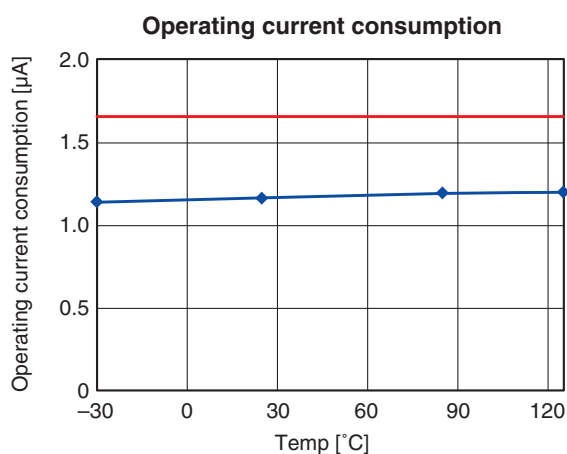
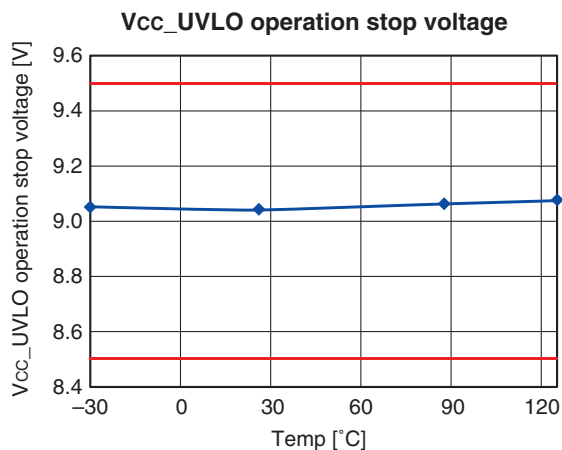
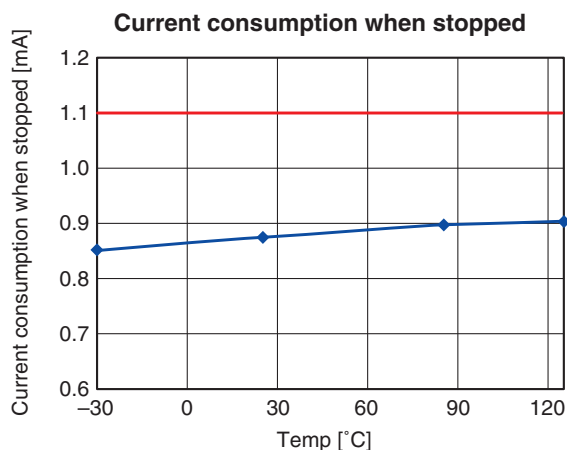
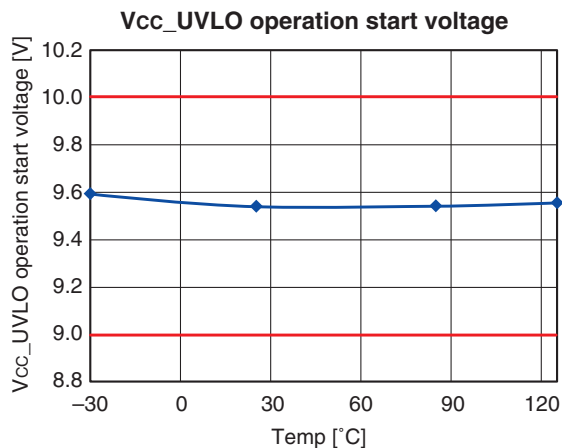
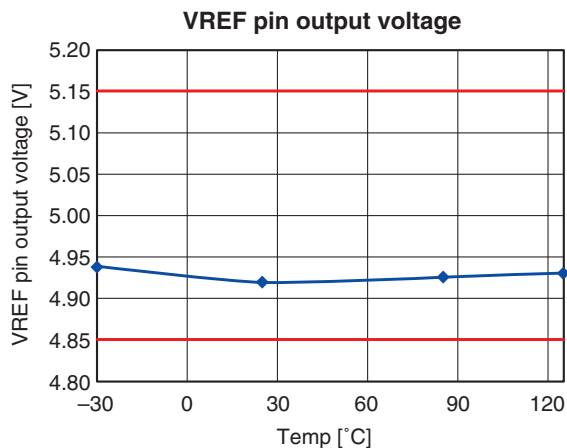
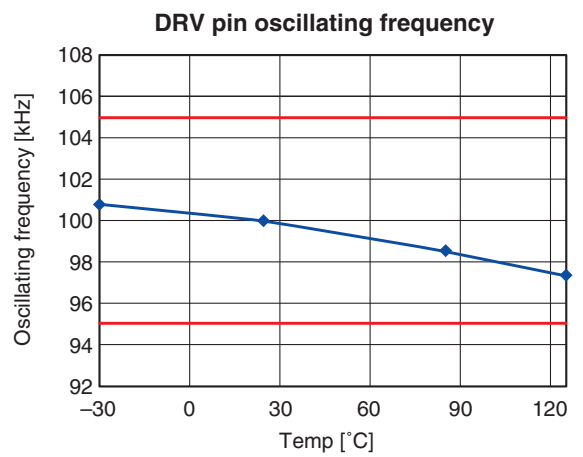
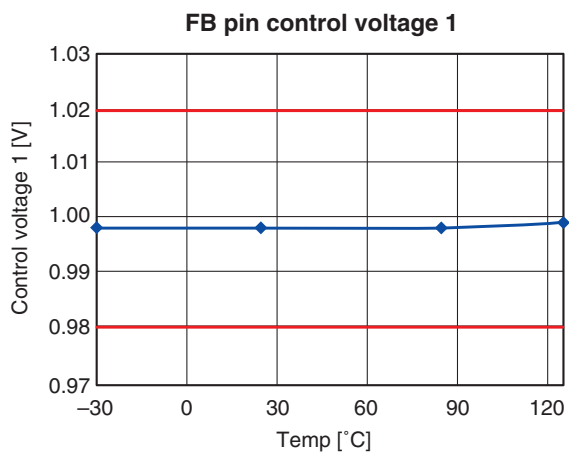
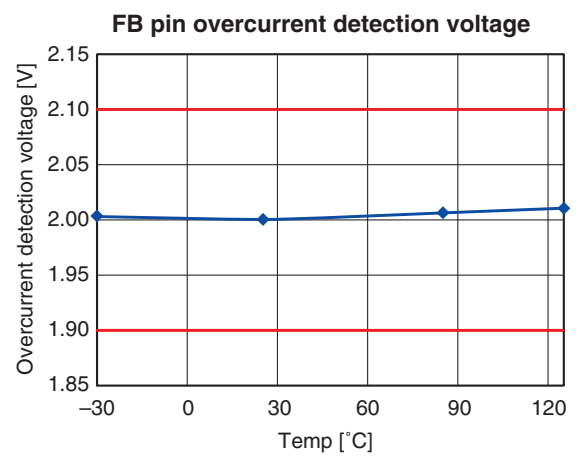
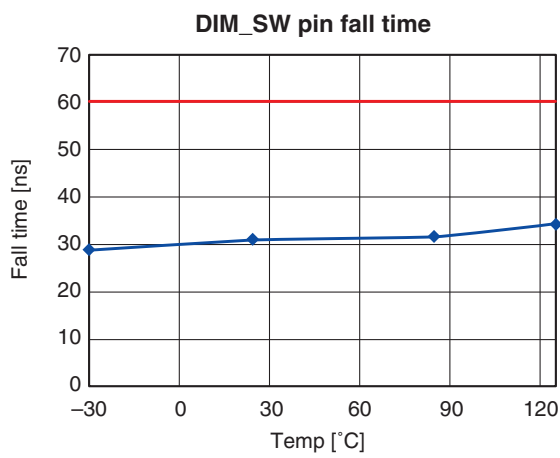
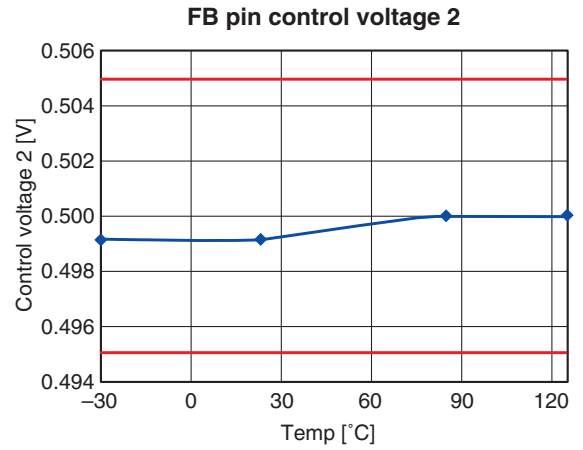
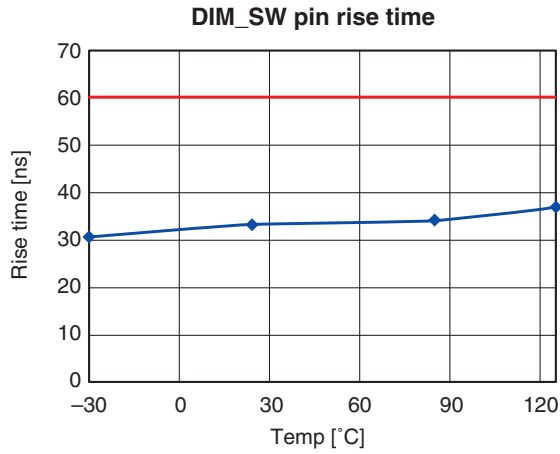

Fig. 17. State Transition Diagram

Note) RESET = High condition : Vcc_UVLO = H or EN = L or VREF_UVLO = H or VREF_OVLO = H
 LATCH1 = High condition : PROTECT = H or OVP = H
 LATCH2 = High condition : TSD = H
 RESET = Low condition : Vcc_UVLO = L and EN = H and VREF_UVLO = L and VREF_OVLO = L

Example of Representative Characteristics





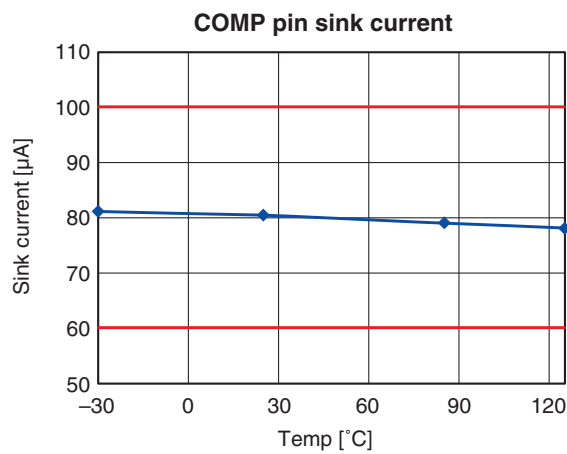
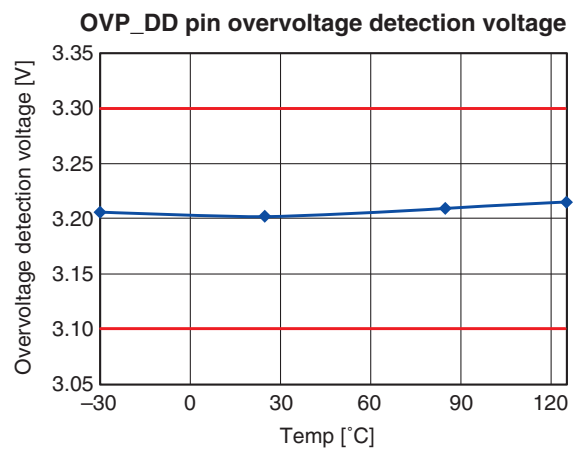
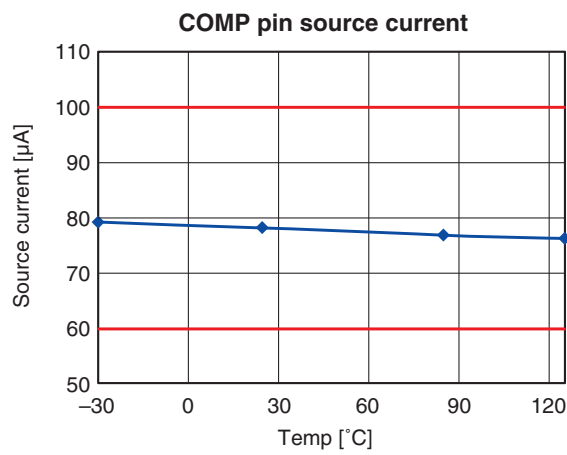
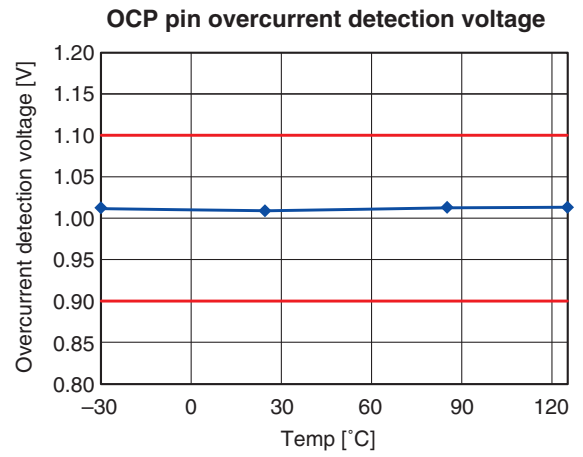
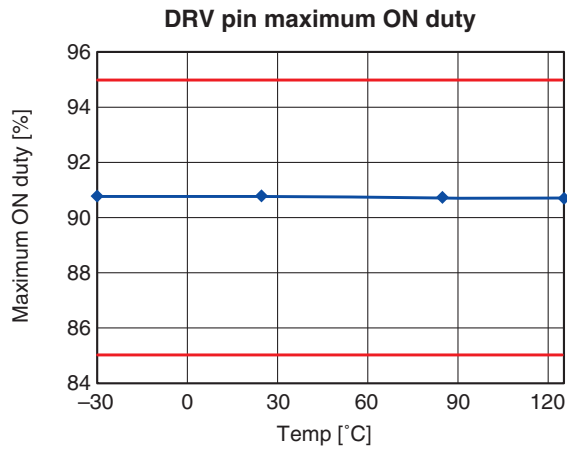

Package Outline

(Unit: mm)

16 PIN SOP (PLASSTIC)

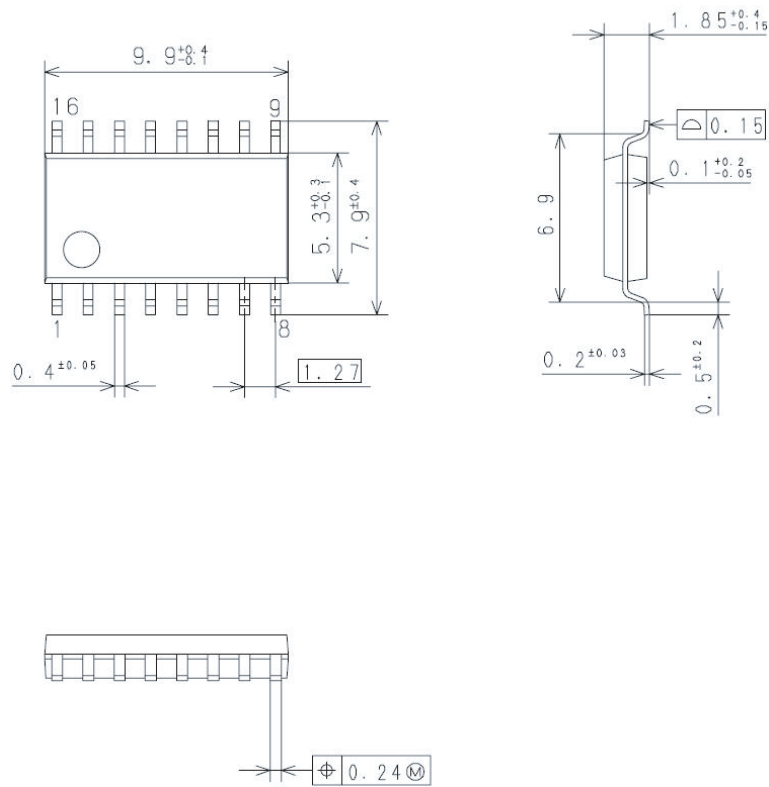

PACKAGE STRUCTURE

SONY CODE	SOP-16P-L01
EIAJ CODE	SOP016-P-0300
JEDEC CODE	_____

PACKAGE MATERIAL	EPOXY RESIN
LEAD TREATMENT	PALLADIUM PLATING
LEAD MATERIAL	COPPER ALLOY
PACKAGE MASS	0.2g.

PART No.	AP-4000-16036S	Rev.	0
ISSUED	11.03.10	REVISED	
PRODUCTION LINE	COMPILING DIV. SDT 技術部 SDT ENGINEERING DIVISION		
REMARKS			