

Preliminary

CXM3543BER

Description

The CXM3543BER is 3P9T antenna switch for quad bands GSM and triple bands CDMA dual mode. This IC has a decoder circuit which supports CMOS control. Sony JPHEMT GaAs process is utilized for low insertion loss and high linearity. (Applications: Quad bands GSM and triple bands CDMA dual mode phones)

Features

- ◆ Low insertion loss
- ◆ High attenuation
- ◆ Low voltage drive: 2.5 to 3.3V
- ◆ Supports CMOS control
- ◆ High ESD resistance
- ◆ Eliminates Output DC Blocking Capacitors to RF ports
- ◆ Lead-Free and RoHS Compliant

Package

VQFN-34P (3.8mm × 4.4mm × 0.85mm Max.)

Structure

GaAs Junction Gate pHEMT (JPHEMT) MMIC Switch, CMOS Decoder

This IC is ESD sensitive device. Special handling precautions are required.

Sony reserves the right to change products and specifications without prior notice. This information does not convey any license by any implication or otherwise under any patents or other right. Application circuits shown, if any, are typical examples illustrating the operation of the devices. Sony cannot assume responsibility for any problems arising out of the use of these circuits.



Absolute Maximum Ratings

◆ Supply voltage	V _{DD}	3.6	V	(T _a = 25°C)
◆ Control voltage	V _{ctl}	3.6	V	(T _a = 25°C)
◆ Maximum input	[GSM Tx1]	36	dBm	(Duty cycle = 12.5%) (T _a = 25°C)
◆	[GSM Tx2]	34	dBm	(Duty cycle = 12.5%) (T _a = 25°C)
◆	[TRx1/2/3]	32	dBm	(T _a = 25°C)
◆	[GSM850/900/1800/1900 Rx]	13	dBm	(T _a = 25°C)
◆ Operating temperature	T _{opr}	-30 to +90	°C	
◆ Storage temperature	T _{stg}	-65 to +150	°C	

Block Diagram

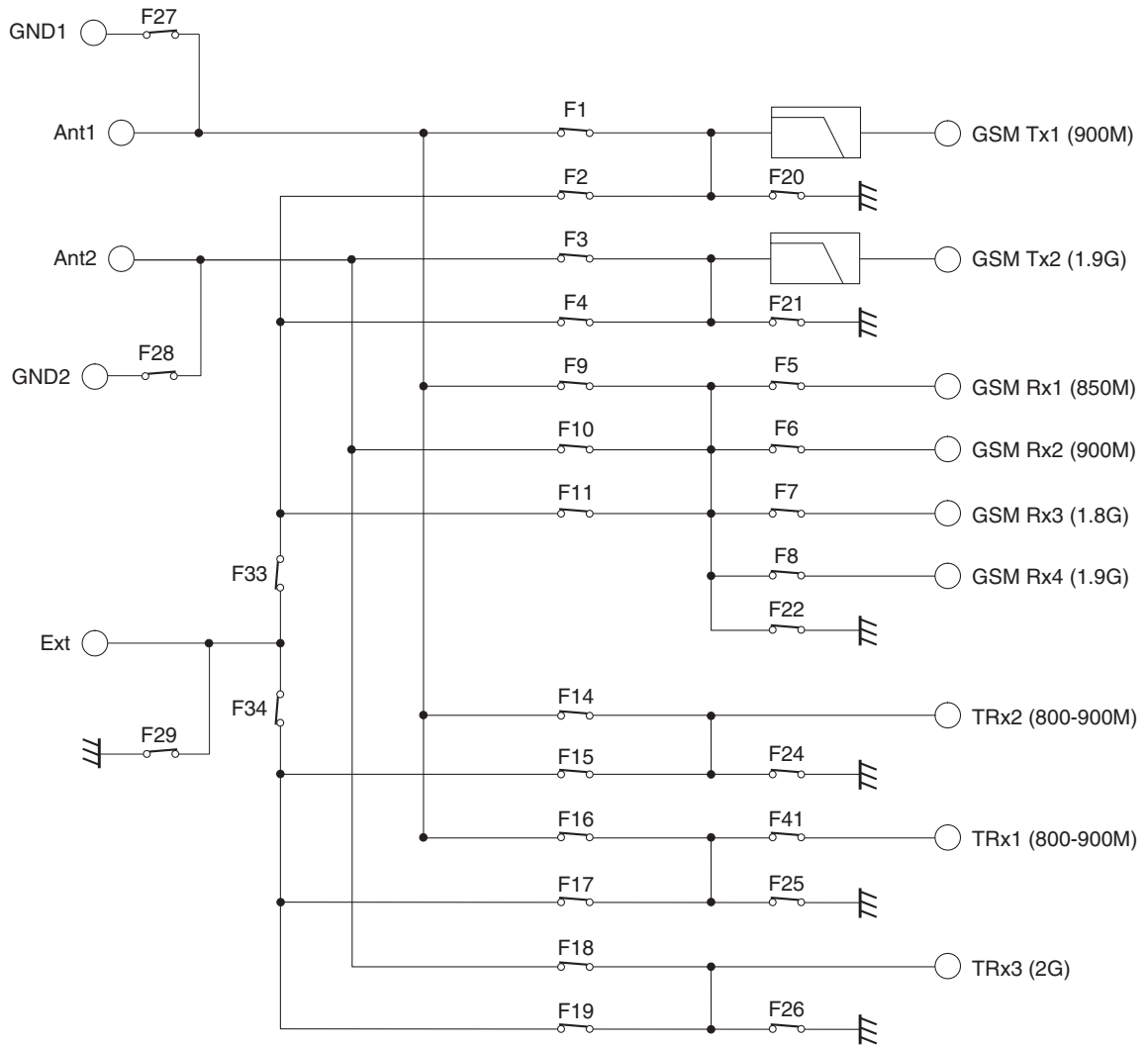

Pin Configuration

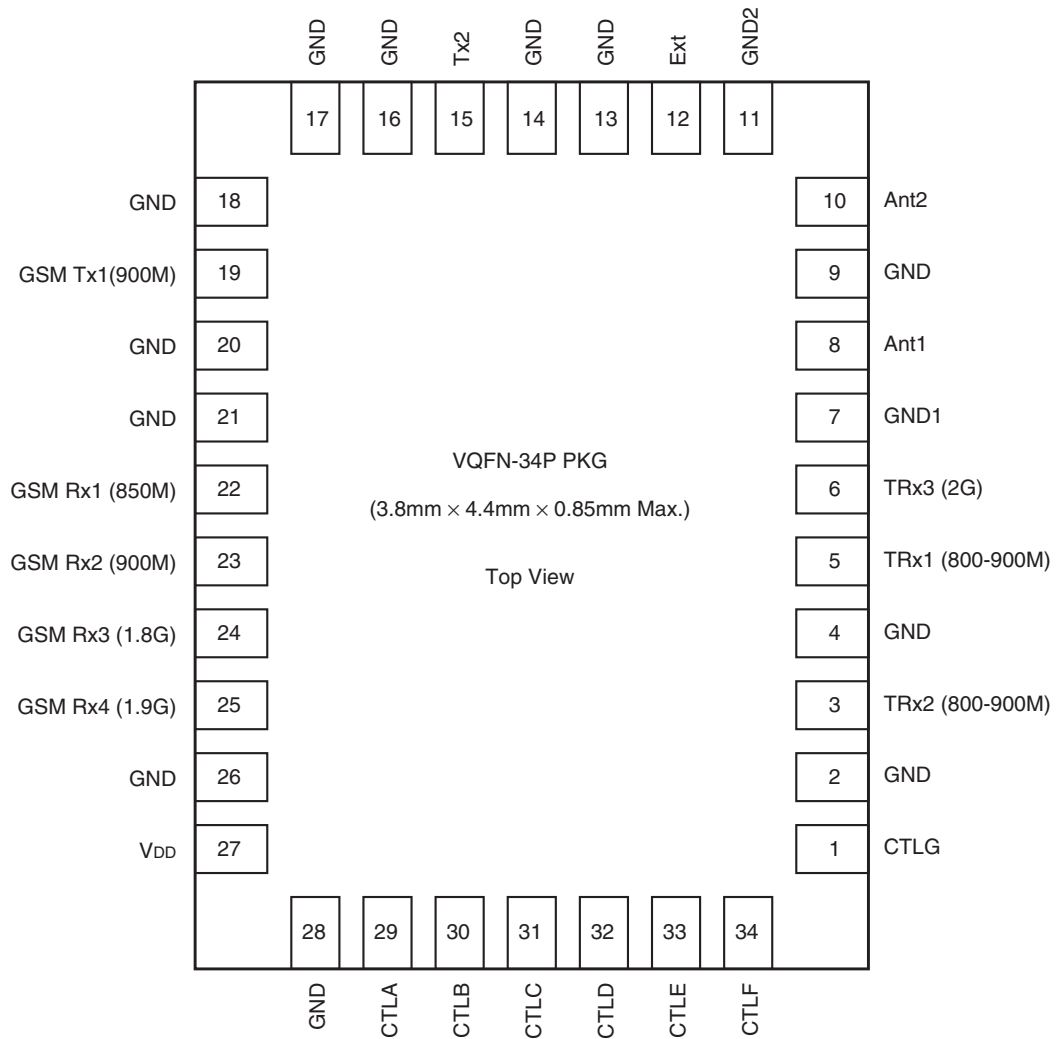

Truth Table

State	CTLA	CTLB	CTLC	CTLD	CTLE	CTLF	CTLG	Active Port	Active Ant	F1	F2	F3	F4	F5	F6	F7	F8	F9	F10	F11	F14	F15	F16	F17	F18	F19
1	H	H	—	H	—	—	H	GSM Tx1	ANT1	ON	OFF	OFF	OFF	OFF	OFF	OFF	OFF	OFF	OFF	OFF	OFF	OFF	OFF	OFF	OFF	OFF
2	H	L	—	H	—	—	H	GSM Tx2	ANT2	OFF	OFF	ON	OFF	OFF	OFF	OFF	OFF	OFF	OFF	OFF	OFF	OFF	OFF	OFF	OFF	OFF
3	H	H	L	L	—	—	H	GSM850 Rx	ANT1	OFF	OFF	OFF	OFF	ON	OFF	OFF	OFF	ON	OFF	OFF	OFF	OFF	OFF	OFF	OFF	OFF
4	H	H	H	L	—	—	H	GSM900 Rx	ANT1	OFF	OFF	OFF	OFF	OFF	ON	OFF	OFF	ON	OFF	OFF	OFF	OFF	OFF	OFF	OFF	OFF
5	H	L	L	L	—	—	H	GSM1800 Rx	ANT2	OFF	OFF	OFF	OFF	OFF	OFF	ON	OFF	OFF	ON	OFF	OFF	OFF	OFF	OFF	OFF	OFF
6	H	L	H	L	—	—	H	GSM1900 Rx	ANT2	OFF	OFF	OFF	OFF	OFF	OFF	OFF	ON	OFF	ON	OFF	OFF	OFF	OFF	OFF	OFF	OFF
7	L	—	—	—	L	H	H	TRx1	ANT1	OFF	OFF	OFF	OFF	OFF	OFF	OFF	OFF	OFF	OFF	OFF	OFF	OFF	ON	OFF	OFF	OFF
8	L	—	—	—	H	L	H	TRx2	ANT1	OFF	OFF	OFF	OFF	OFF	OFF	OFF	OFF	OFF	OFF	OFF	ON	OFF	OFF	OFF	OFF	OFF
9	L	—	—	—	L	L	H	TRx3	ANT2	OFF	OFF	OFF	OFF	OFF	OFF	OFF	OFF	OFF	OFF	OFF	OFF	OFF	OFF	OFF	ON	OFF
10	H	H	—	H	—	—	L	GSM Tx1	EXT	OFF	ON	OFF	OFF	OFF	OFF	OFF	OFF	OFF	OFF	OFF	OFF	OFF	OFF	OFF	OFF	OFF
11	H	L	—	H	—	—	L	GSM Tx2	EXT	OFF	OFF	OFF	ON	OFF	OFF	OFF	OFF	OFF	OFF	OFF	OFF	OFF	OFF	OFF	OFF	OFF
12	H	H	L	L	—	—	L	GSM850 Rx	EXT	OFF	OFF	OFF	OFF	ON	OFF	OFF	OFF	OFF	OFF	ON	OFF	OFF	OFF	OFF	OFF	OFF
13	H	H	H	L	—	—	L	GSM900 Rx	EXT	OFF	OFF	OFF	OFF	OFF	ON	OFF	OFF	OFF	OFF	ON	OFF	OFF	OFF	OFF	OFF	OFF
14	H	L	L	L	—	—	L	GSM1800 Rx	EXT	OFF	OFF	OFF	OFF	OFF	OFF	ON	OFF	OFF	OFF	ON	OFF	OFF	OFF	OFF	OFF	OFF
15	H	L	H	L	—	—	L	GSM1900 Rx	EXT	OFF	OFF	OFF	OFF	OFF	OFF	OFF	ON	OFF	OFF	ON	OFF	OFF	OFF	OFF	OFF	OFF
16	L	—	—	—	L	H	L	TRx1	EXT	OFF	OFF	OFF	OFF	OFF	OFF	OFF	OFF	OFF	OFF	OFF	OFF	OFF	OFF	ON	OFF	OFF
17	L	—	—	—	H	L	L	TRx2	EXT	OFF	OFF	OFF	OFF	OFF	OFF	OFF	OFF	OFF	OFF	OFF	OFF	ON	OFF	OFF	OFF	OFF
18	L	—	—	—	L	L	L	TRx3	EXT	OFF	OFF	OFF	OFF	OFF	OFF	OFF	OFF	OFF	OFF	OFF	OFF	OFF	OFF	OFF	OFF	ON

State	CTLA	CTLB	CTLC	CTLD	CTLE	CTLF	CTLG	Active Port	Active Ant	F20	F21	F22	F24	F25	F26	F27	F28	F29	F33	F34	F41				
1	H	H	—	H	—	—	H	GSM Tx1	ANT1	OFF	ON	ON	ON	ON	ON	OFF	ON	ON	OFF	OFF	OFF				
2	H	L	—	H	—	—	H	GSM Tx2	ANT2	ON	OFF	ON	ON	ON	ON	ON	OFF	ON	OFF	OFF	ON				
3	H	H	L	L	—	—	H	GSM850 Rx	ANT1	ON	ON	OFF	ON	ON	ON	OFF	ON	ON	OFF	OFF	ON				
4	H	H	H	L	—	—	H	GSM900 Rx	ANT1	ON	ON	OFF	ON	ON	ON	OFF	ON	ON	OFF	OFF	ON				
5	H	L	L	L	—	—	H	GSM1800 Rx	ANT2	ON	ON	OFF	ON	ON	ON	ON	OFF	ON	OFF	OFF	ON				
6	H	L	H	L	—	—	H	GSM1900 Rx	ANT2	ON	ON	OFF	ON	ON	ON	ON	OFF	ON	OFF	OFF	ON				
7	L	—	—	—	L	H	H	TRx1	ANT1	ON	ON	ON	ON	OFF	ON	OFF	ON	ON	OFF	OFF	ON				
8	L	—	—	—	H	L	H	TRx2	ANT1	ON	ON	ON	OFF	ON	ON	OFF	OFF	ON	OFF	OFF	ON				
9	L	—	—	—	L	L	H	TRx3	ANT2	ON	ON	ON	ON	ON	OFF	ON	OFF	ON	OFF	OFF	ON				
10	H	H	—	H	—	—	L	GSM Tx1	EXT	OFF	ON	ON	ON	ON	ON	ON	ON	OFF	ON	OFF	OFF				
11	H	L	—	H	—	—	L	GSM Tx2	EXT	ON	OFF	ON	ON	ON	ON	ON	ON	OFF	ON	OFF	ON				
12	H	H	L	L	—	—	L	GSM850 Rx	EXT	ON	ON	OFF	ON	ON	ON	ON	ON	OFF	ON	OFF	ON				
13	H	H	H	L	—	—	L	GSM900 Rx	EXT	ON	ON	OFF	ON	ON	ON	ON	ON	OFF	ON	OFF	ON				
14	H	L	L	L	—	—	L	GSM1800 Rx	EXT	ON	ON	OFF	ON	ON	ON	ON	ON	OFF	ON	OFF	ON				
15	H	L	H	L	—	—	L	GSM1900 Rx	EXT	ON	ON	OFF	ON	ON	ON	ON	ON	OFF	ON	OFF	ON				
16	L	—	—	—	L	H	L	TRx1	EXT	ON	ON	ON	ON	OFF	ON	ON	ON	OFF	OFF	ON	ON				
17	L	—	—	—	H	L	L	TRx2	EXT	ON	ON	ON	OFF	ON	ON	ON	ON	OFF	OFF	ON	ON				
18	L	—	—	—	L	L	L	TRx3	EXT	ON	ON	ON	ON	ON	OFF	ON	ON	OFF	OFF	ON	ON				

**DC Bias Conditions**

(Ta = +25°C)

Item	Min.	Typ.	Max.	Unit
V _{DD}	2.5	2.85	3.3	V
V _{ctl} (H)	1.5	1.85	3.3	V
V _{ctl} (L)	0	—	0.3	V

Electrical Characteristics

(V_{DD} = 2.85V, T_a = +25°C)

Item	Min.	Typ.	Max.	Unit	Conditions
Bias current		280	500	μA	V _{DD} = 2.85V, V _{ctl} = 0V
Ctrl current		0	10	μA	V _{ctl} = 1.85V
Wake up time		—	100	μs	V _{DD} = 0 to 2.85V
Switching speed		—	5	μs	

CDMA 800, 900MHz (TRx1 – Ant1/Ext)

(V_{DD} = 2.85V, T_a = +25°C)

Item	Freq [MHz]	Ant			Ext			Unit	Conditions
		Min.	Typ.	Max.	Min.	Typ.	Max.		
Insertion loss	824 to 875		0.50	0.65		0.55	0.70	dB	
	843 to 925		0.50	0.65		0.55	0.70		
VSWR	824 to 875		1.10			1.10		—	TRx1 Port
	843 to 925		1.10			1.10		—	
	824 to 875		1.10			1.10		—	Ant, Ext Port
	843 to 925		1.10			1.10		—	
SW isolation	824 to 875	16	32		16	32		dB	TRx1 - Ant2/Ext measurement (Ant1 ON) TRx1 - Ant1/Ant2 measurement (Ext ON)
	843 to 925	16	32		16	32			
Harmonics	1648 to 1850		—	−44		—	−44	dBm	Pin = 25dBm
	2472 to 2775		—	−44		—	−44		
	3296 to 3700		—	−44		—	−44		
ACPR	824 to 830	±900kHz		—	−50		—	dBc	Pin = 25dBm, RBW = 30kHz Channel power measurement
	824 to 849	±1.98MHz		—	−55		—		
IIP3	843 to 875	63	67		62	66		dBm	Pin = 25dBm

Electrical characteristics are measured with all RF ports terminated in 50Ω.

CDMA 800, 900MHz (TRx2 – Ant1/Ext)

(V_{DD} = 2.85V, T_a = +25°C)

Item	Freq [MHz]		Ant			Ext			Unit	Conditions
			Min.	Typ.	Max.	Min.	Typ.	Max.		
Insertion loss	824 to 875			0.45	0.60		0.50	0.65	dB	
	843 to 925			0.45	0.60		0.50	0.65		
VSWR	824 to 875			1.15			1.10		—	TRx2 Port
	843 to 925			1.15			1.10			
	824 to 875			1.15			1.10		—	Ant, Ext Port
	843 to 925			1.15			1.10			
SW isolation	824 to 875		16	32		16	32	dB	TRx2 - Ant2/Ext measurement (Ant1 ON) TRx2 - Ant1/Ant2 measurement (Ext ON)	
	843 to 925		16	32		16	32			
Harmonics	1648 to 1850			—	-44		—	-44	dBm	Pin = 25dBm
	2472 to 2775			—	-44		—	-44		
	3296 to 3700			—	-44		—	-44		
ACPR	824 to 830 898 to 925	±900kHz		—	-50		—	-50	dBc	Pin = 25dBm, RBW = 30kHz Channel power measurement
		±1.98MHz		—	-55		—	-55		
IIP3	843 to 875		63	68		63	67	dBm	Pin = 25dBm	

Electrical characteristics are measured with all RF ports terminated in 50Ω.

CDMA 2GHz (TRx3 – Ant2/Ext)

(V_{DD} = 2.85V, T_a = +25°C)

Item	Freq [MHz]		Ant			Ext			Unit	Conditions
			Min.	Typ.	Max.	Min.	Typ.	Max.		
Insertion loss	1920 to 1940			0.65	0.80		0.70	0.85	dB	
	2110 to 2130			0.65	0.80		0.75	0.90		
VSWR	1920 to 1940			1.35			1.20		—	TRx3 Port
	2110 to 2130			1.35			1.20			
	1920 to 1940			1.35			1.10		—	Ant, Ext Port
	2110 to 2130			1.35			1.10			
SW isolation	1920 to 1940		16	24		16	22	dB	TRx3 - Ant1/Ext measurement (Ant2 ON) TRx3 - Ant1/Ant2 measurement (Ext ON)	
	2110 to 2130		16	24		16	22			
Harmonics	3840 to 3880			—	-44		—	-44	dBm	Pin = 25dBm
	5760 to 5820			—	-44		—	-44		
	7680 to 7760			—	-44		—	-44		
ACPR	1920 to 1940	±1.25MHz		—	-50		—	-50	dBc	Pin = 25dBm, RBW = 30kHz Channel power measurement
		±1.95MHz		—	-55		—	-55		
IIP3	2110 to 2130		63	67		63	66	dBm	Pin = 25dBm	

Electrical characteristics are measured with all RF ports terminated in 50Ω.

GSM850M/GSM900M-Tx (Tx1 – Ant1/Ext)

(V_{DD} = 2.85V, T_a = +25°C)

Item	Freq [MHz]		Ant			Ext			Unit	Conditions
			Min.	Typ.	Max.	Min.	Typ.	Max.		
Insertion loss	824 to 849			0.85	1.00		1.00	1.15	dB	
	880 to 915			0.85	1.00		1.00	1.15		
VSWR	824 to 849			1.35			1.30		—	GSM Tx1 Port
	880 to 915									
	824 to 849			1.30			1.25			
	880 to 915									
SW isolation	824 to 849		25	30		25	34		dB	GSM Tx1 – Ant2/Ext measurement (Ant1 ON) GSM Tx1 – Ant1/Ant2 measurement (Ext ON)
	880 to 915		25	30		25	34			
Isolation Tx ⇒ Rx	824 to 915		31	53		31	50		dB	Tx1 ⇒ 850Rx when selecting Tx1 – Ant1 and Ext
			31	63		31	56			Tx1 ⇒ 900Rx when selecting Tx1 – Ant1 and Ext
			31	64		31	58			Tx1 ⇒ 1800Rx when selecting Tx1 – Ant1 and Ext
			31	66		31	58			Tx1 ⇒ 1900Rx when selecting Tx1 – Ant1 and Ext
			31	53		31	71			Tx1 ⇒ TRx1 when selecting Tx1 – Ant1 and Ext
			31	36		31	46			Tx1 ⇒ TRx2 when selecting Tx1 – Ant1 and Ext
			28	31		31	45			Tx1 ⇒ TRx3 when selecting Tx1 – Ant1 and Ext
Harmonics	1648 to 1830	2Tx		-47	-36		-44	-36	dBm	Pin = 35dBm
	2472 to 2745	3Tx		-46	-36		-42	-36		
	3296 to 3660	4Tx		—	-36		—	-36		
Attenuation	1648 to 1830	2Tx	25	33		25	31		dB	Pin = 35dBm
	2472 to 2745	3Tx	23	30		23	30			
	3296 to 3660	4Tx	20	44		20	38			

Electrical characteristics are measured with all RF ports terminated in 50Ω.

DSC/PCS-Tx (Tx2 – Ant2/Ext)

(V_{DD} = 2.85V, T_a = +25°C)

Item	Freq [MHz]		Ant			Ext			Unit	Conditions
			Min.	Typ.	Max.	Min.	Typ.	Max.		
Insertion loss	1710 to 1785			0.95	1.10		1.10	1.25	dB	
	1850 to 1910			1.00	1.15		1.10	1.25		
VSWR	1710 to 1785			1.40			1.50		—	GSM Tx2 Port
	1850 to 1910									
	1710 to 1785			1.50			1.30			
	1850 to 1910									
SW isolation	1710 to 1785		22	27		20	25	dB	GSM Tx2 – Ant1/Ext measurement (Ant2 ON) GSM Tx2 – Ant1/Ant2 measurement (Ext ON)	
	1850 to 1910		22	27		20	25			
Isolation Tx ⇒ Rx	1710 to 1910		31	56		31	42	dB	Tx2 ⇒ 850Rx when selecting Tx2 – Ant2 and Ext	
			31	61		31	53		Tx2 ⇒ 900Rx when selecting Tx2 – Ant2 and Ext	
			31	61		31	55		Tx2 ⇒ 1800Rx when selecting Tx2 – Ant2 and Ext	
			31	62		31	56		Tx2 ⇒ 1900Rx when selecting Tx2 – Ant2 and Ext	
			26	30		29	33		Tx2 ⇒ TRx1 when selecting Tx2 – Ant2 and Ext	
			29	33		31	36		Tx2 ⇒ TRx2 when selecting Tx2 – Ant2 and Ext	
			25	29		29	33		Tx2 ⇒ TRx3 when selecting Tx2 – Ant2 and Ext	
Harmonics	3420 to 3570	2Tx		-55	-39		-50	-36	dBm	Pin = 32dBm
	3700 to 3820			-55	-39		-47	-39		
	5130 to 5355	3Tx		-55	-39		-52	-36		
	5550 to 5730			-55	-39		-50	-39		
Attenuation	3420 to 3570	2Tx	25	33		25	36	dB	Pin = 32dBm	
	3700 to 3820		25	28		25	33			
	5130 to 5355	3Tx	25	37		21	27			
	5550 to 5730		20	36		19	25			

Electrical characteristics are measured with all RF ports terminated in 50Ω.

GSM850M-Rx (GSM850Rx – Ant1/Ext)(V_{DD} = 2.85V, T_a = +25°C)

Item	Freq [MHz]	Ant			Ext			Unit	Conditions
		Min.	Typ.	Max.	Min.	Typ.	Max.		
Insertion loss	869 to 894		0.90	1.05		0.95	1.10	dB	
VSWR	869 to 894		1.20			1.20		—	GSM850Rx Port
	869 to 894		1.10			1.10			Ant, Ext Port

Electrical characteristics are measured with all RF ports terminated in 50Ω.

GSM900M-Rx (GSM900Rx – Ant1/Ext)(V_{DD} = 2.85V, T_a = +25°C)

Item	Freq [MHz]	Ant			Ext			Unit	Conditions
		Min.	Typ.	Max.	Min.	Typ.	Max.		
Insertion loss	925 to 960		0.90	1.05		1.00	1.15	dB	
VSWR	925 to 960		1.20			1.20		—	GSM900Rx Port
	925 to 960		1.10			1.10			Ant, Ext Port

Electrical characteristics are measured with all RF ports terminated in 50Ω.

DCS-Rx (GSM1800Rx – Ant2/Ext)(V_{DD} = 2.85V, T_a = +25°C)

Item	Freq [MHz]	Ant			Ext			Unit	Conditions
		Min.	Typ.	Max.	Min.	Typ.	Max.		
Insertion loss	1805 to 1880		1.10	1.25		1.15	1.30	dB	
VSWR	1805 to 1880		1.30			1.20		—	GSM1800Rx Port
	1805 to 1880		1.20			1.10			Ant, Ext Port

Electrical characteristics are measured with all RF ports terminated in 50Ω.

PCS-Rx (GSM1900Rx – Ant2/Ext)(V_{DD} = 2.85V, T_a = +25°C)

Item	Freq [MHz]	Ant			Ext			Unit	Conditions
		Min.	Typ.	Max.	Min.	Typ.	Max.		
Insertion loss	1930 to 1990		1.10	1.25		1.15	1.30	dB	
VSWR	1930 to 1990		1.35			1.20		—	GSM1900Rx Port
	1930 to 1990		1.20			1.05			Ant, Ext Port

Electrical characteristics are measured with all RF ports terminated in 50Ω.

Recommended Circuit

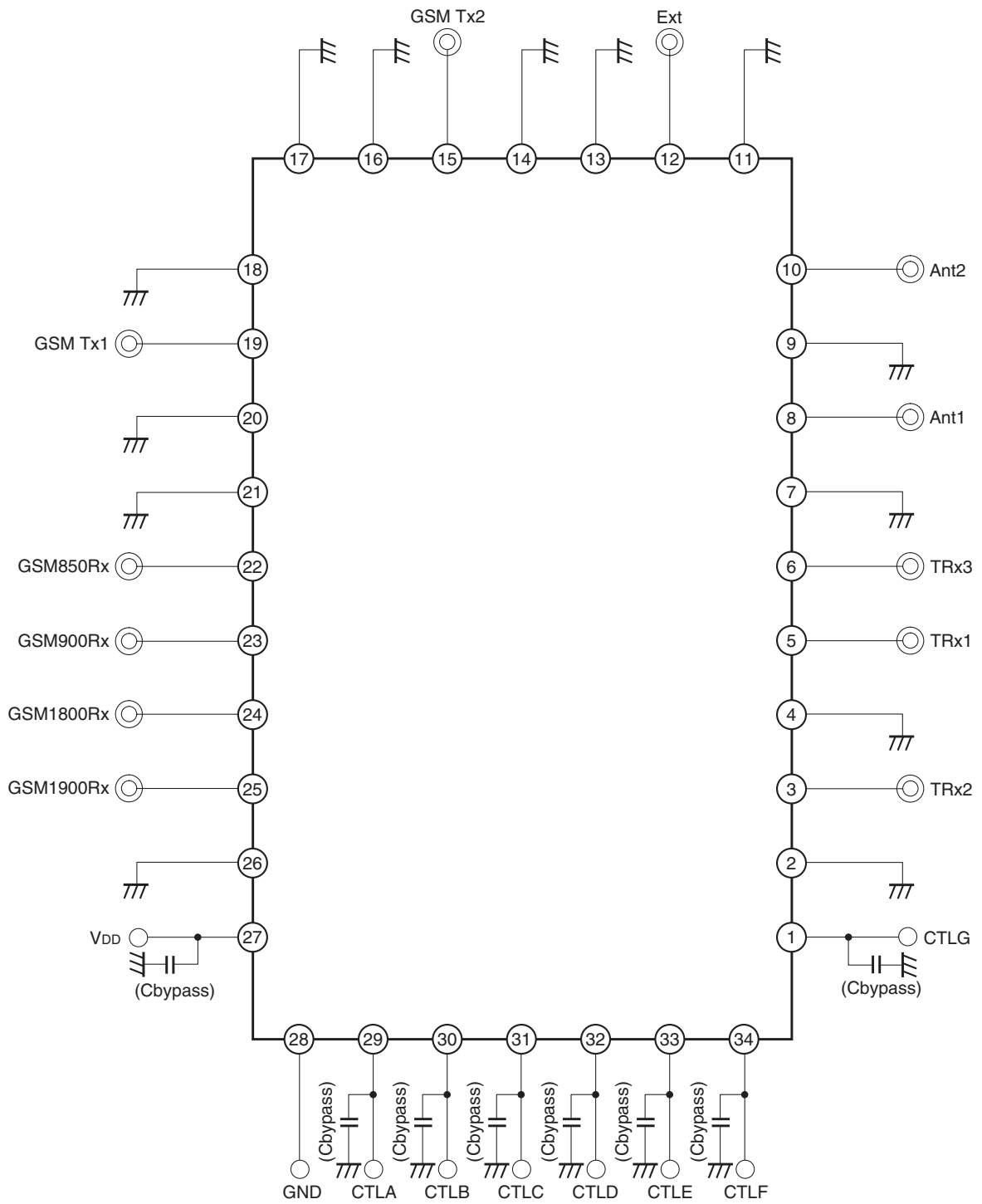

- *1 No DC blocking capacitors are required on all RF ports.
- *2 The DC levels of all RF ports are GND.
- *3 Cbypass: This capacitor is used for DC line bypass. (100pF is recommended)

Package Outline

(Unit: mm)

34 PIN VQFN (PLASTIC)

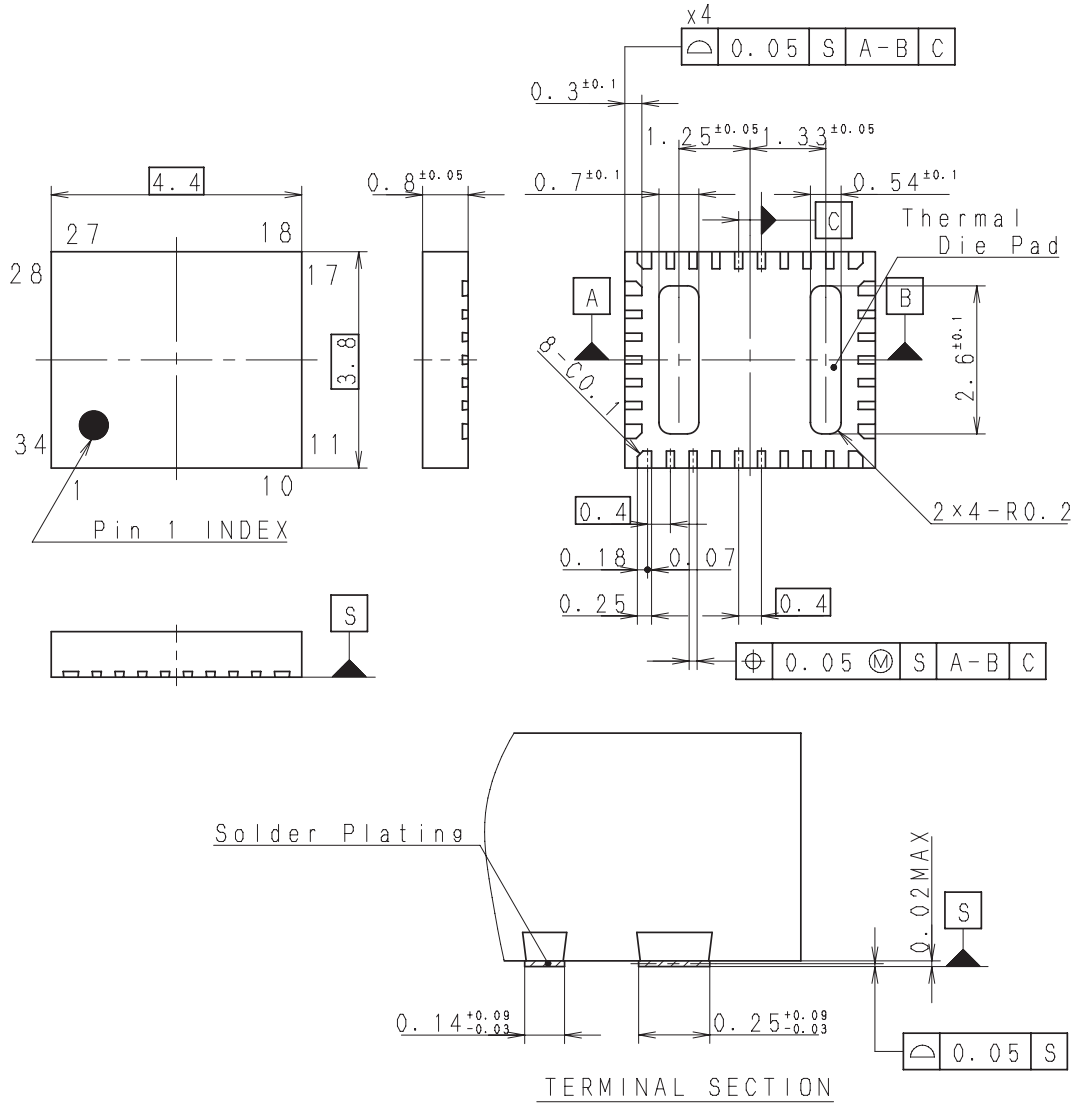

Note: Cutting burr of lead are 0.05mm MAX.

TERMINAL SECTION

PACKAGE STRUCTURE

SONY CODE	VQFN-34P-01
JEITA CODE	_____
JEDEC CODE	_____

PACKAGE MATERIAL	EPOXY RESIN
TERMINAL TREATMENT	SOLDER PLATING
TERMINAL MATERIAL	COPPER ALLOY
PACKAGE MASS	0.04g

AP-4000-34001S Rev. 0

LEAD PLATING SPECIFICATIONS

ITEM	SPEC.
LEAD MATERIAL	COPPER ALLOY
SOLDER COMPOSITION	Sn-Bi Bi:1-4wt%
PLATING THICKNESS	5-18µm