

# CXA3815N

---

## Description

Audio IC for LCD-TVs

---

## Features

- ◆ Operating voltage  $V_{CC} = 3.0$  to  $3.6V$
- ◆ Differential input
- ◆ Output decoupling capacitor less
- ◆ Gain switching function (6dB/12dB)
- ◆ Mute function

---

## Structure

BiCMOS monolithic IC

---

## Package

SSOP-16P-L01

Sony reserves the right to change products and specifications without prior notice. This information does not convey any license or any implication or otherwise under any patents or other right. Application circuits shown, if any, are typical examples illustrating the operation of the devices. Sony cannot assume responsibility for any problems arising out of the use of these circuits.

Block Diagram

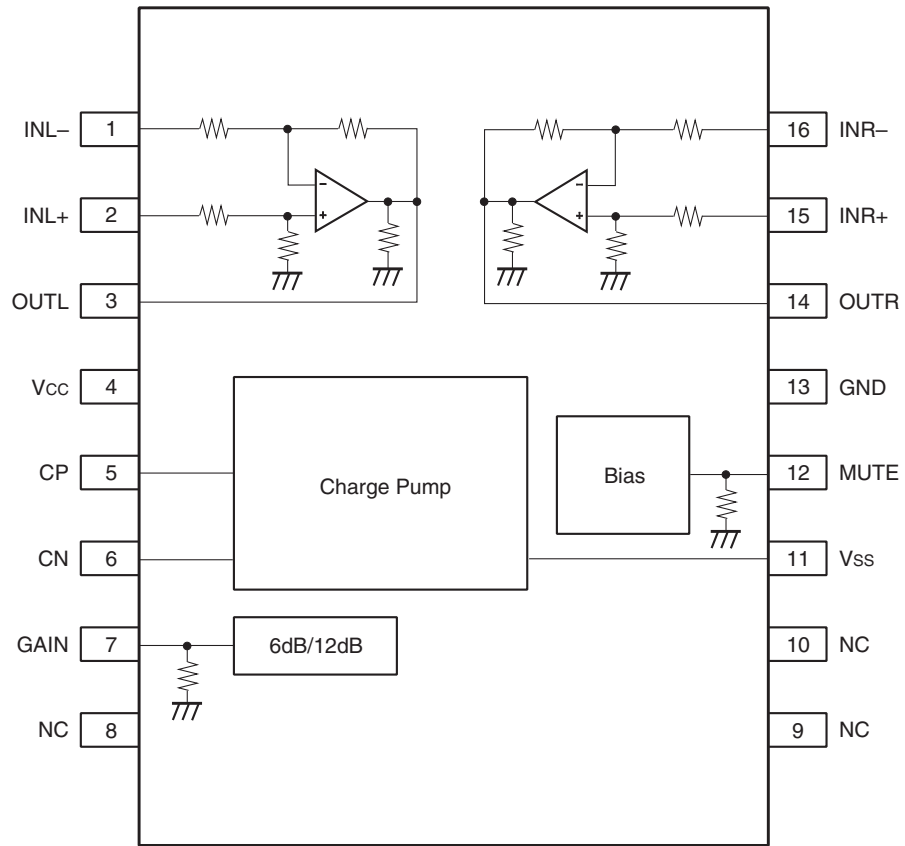

Pin Description

Pin No.	Symbol	I/O	Pin voltage [V]		Equivalent circuit	Description
			DC	AC		
1	INL-	I	0	—		HP AMP_L input (-)
16	INR-	I	0	—		HP AMP_R input (-)
2	INL+	I	0	—		HP AMP_L input (+)
15	INR+	I	0	—		HP AMP_R input (+)
3	OUTL	O	0	—		HP AMP_L output
14	OUTR	O	0	—		HP AMP_R output

Pin No.	Symbol	I/O	Pin voltage [V]		Equivalent circuit	Description
			DC	AC		
5	CP	I/O	—	3.3		CP capacitance connection
6	CN	I/O	—	-3.3		CP capacitance connection
11	Vss	I/O	-3.26	—		Vss
7	GAIN	I	0	—		Gain switching
12	MUTE	I	0	—		Mute switching
4	Vcc	I/O	—	—		Vcc
13	GND	I/O	—	—		GND

## Electrical Characteristics

Unless otherwise specified

( $V_{CC} = 3.3V$ ,  $T_a = 25^{\circ}C$ ,  $f_{signal} = 1kHz$ , differential input, Measurement band width = 20Hz to 20kHz)

### Power

Item	Symbol	Conditions	Min.	Typ.	Max.	Unit
Supply voltage	$V_{CC}$		3.0	3.3	3.6	V
Maximum rating	$V_{max}$		—	—	4.5	V
Operating temperature	$T_a$		-25	—	+85	$^{\circ}C$

### Amplifier Block

Item	Symbol	Conditions	Min.	Typ.	Max.	Unit
Input impedance	$R_{in}$		96	120	144	$k\Omega$
Gain1	$G_{v1}$	GAIN Low, 0.1Vrms input	5.5	6	6.5	dB
Gain2	$G_{v2}$	GAIN High, 0.1Vrms input	11.5	12	12.5	dB
Total harmonic distortion 1	THD1	$R_L = 33 + 32\Omega$ GAIN Low, 0.1Vrms input	—	0.01	0.1	%
Total harmonic distortion 2	THD2	$R_L = 33 + 32\Omega$ , $P_o = 15mW$ GAIN Low	—	—	0.5	%
Total harmonic distortion 3	THD3	$R_L = 470 + 10k\Omega$ , $V_o = 2.0Vrms$ GAIN Low	—	—	1	%
Output noise level	$V_{no}$	No signal input, measured at $32\Omega$ ends	—	-100	-95	dBv
Channel separation	CS	$R_L = 33 + 32\Omega$ , $P_o = 15mW$ 1kHz BPF, GAIN Low	70	80	—	dB
DC offset	$V_{os}$	No signal input, GAIN Low	-5	—	5	mV
Mute level	$V_{mute}$	$R_L = 33 + 32\Omega$ , $P_o = 15mW$ GAIN Low, MUTE ON	—	-70	-60	dB

### Control Block

Item	Symbol	Conditions	Min.	Typ.	Max.	Unit
Mute H	MuteH	Mute = OFF	$0.7V_{CC}$	—	$V_{CC}$	V
Mute L	MuteL	Mute = ON	0	—	0.8	V
Gain H	GainH	Gain = 12dB	$0.7V_{CC}$	—	$V_{CC}$	V
Gain L	GainL	Gain = 6dB	0	—	0.8	V

Application Circuit

Single Input

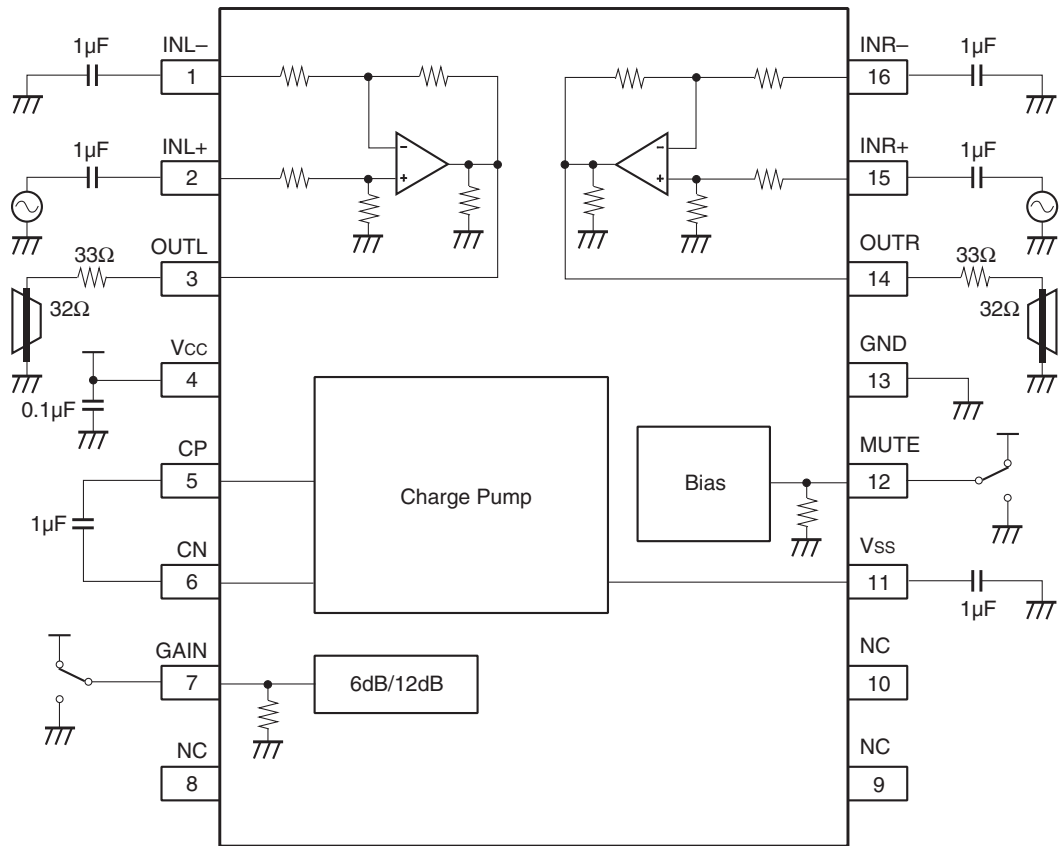

Differential Input

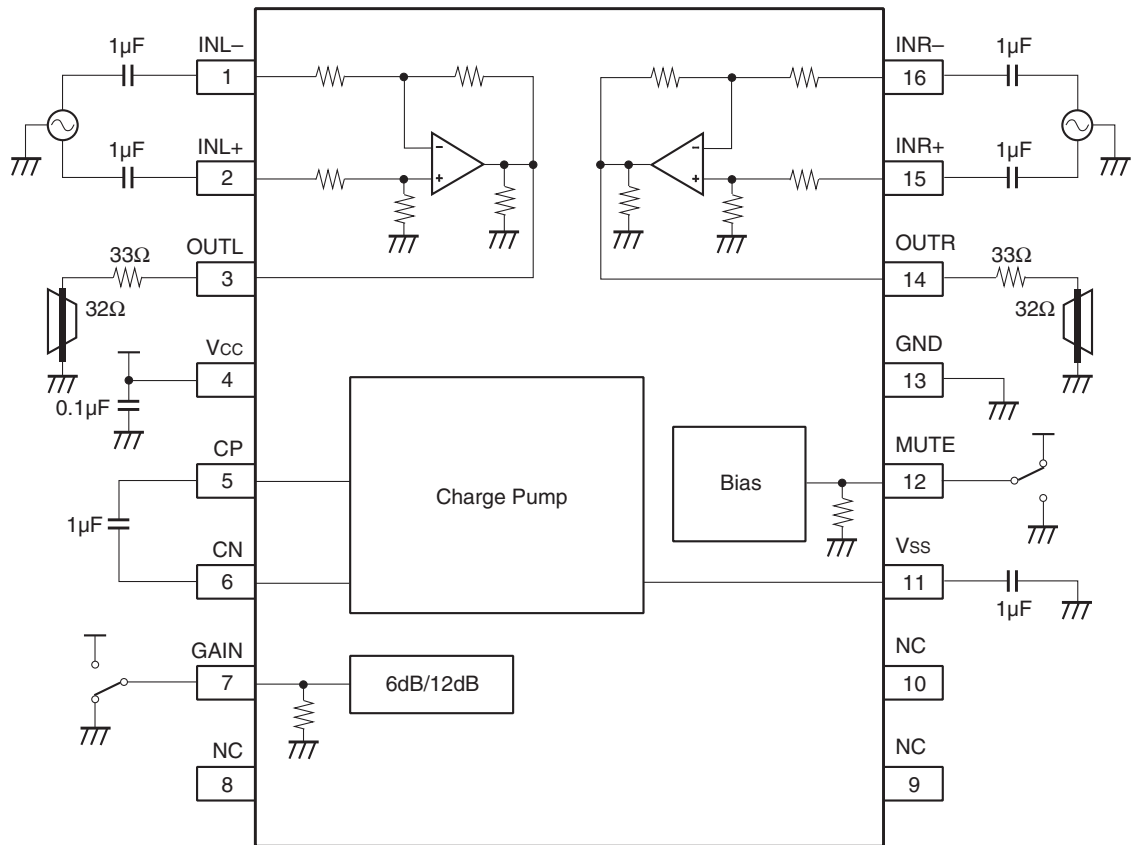



### Notes On Handling

- ◆ The capacitor between CP and CN pin and connected to Vss pin are for generating negative voltage. Place these capacitors with the shortest wiring to the pins.
- ◆ The capacitor connected to Vcc pin is for smoothing noise. Place this capacitor with the shortest wiring to the pin.

Package Outline

(Unit : mm)

16PIN SSOP (PLASTIC)

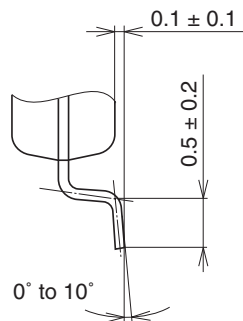
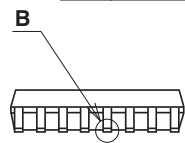
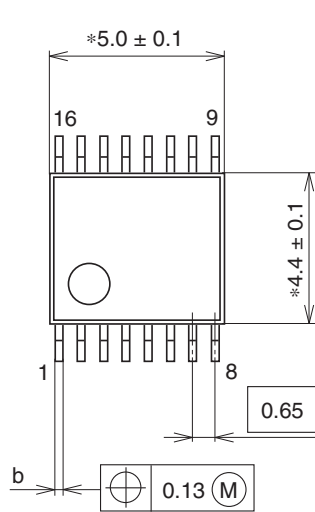

DETAIL A

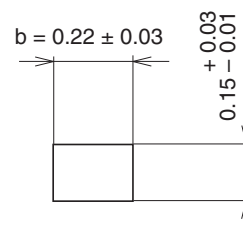
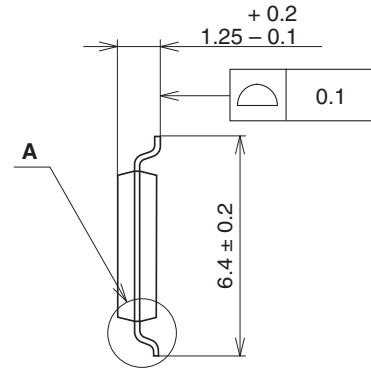

DETAIL B : PALLADIUM

NOTE: Dimension "\*" does not include mold protrusion.

PACKAGE STRUCTURE

SONY CODE	SSOP-16P-L01	PACKAGE MATERIAL	EPOXY RESIN
EIAJ CODE	P-SSOP16-4.4x5.0-0.65	LEAD TREATMENT	PALLADIUM PLATING
JEDEC CODE	_____	LEAD MATERIAL	COPPER ALLOY
		PACKAGE MASS	0.1g