

## High Isolation Absorptive SPDT Switch MMIC with Integrated Control Logic

**Description**

The CXG1039TN is a high isolation absorptive SPDT (Single Pole Dual Throw) switch MMIC used in PCS handsets.

This IC is designed using the Sony's GaAs J-FET process and operates with CMOS input.

**Features**

- Absorptive type
- CMOS input control
- Low insertion loss 0.8 dB (Typ.) at 2.0 GHz
- High isolation 50 dB (Typ.) at 2.0 GHz
- Small Package TSSOP-10pin

**Applications**

High isolation switch for digital cellular telephones such as PCS handsets.

**Structure**

GaAs J-FET MMIC

10 pin TSSOP (Plastic)

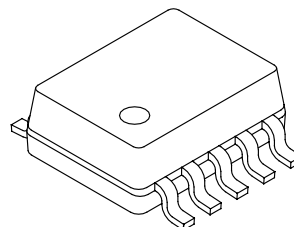
**Absolute Maximum Ratings** ( $T_a=25\text{ }^\circ\text{C}$ )

• Supply voltage	$V_{DD}$	7	V
• Control voltage	$V_{ctl}$	5	V
• Input power	$P_{in}$	25	dBm
• Operating temperature	$T_{opr}$	-35 to +85	$^\circ\text{C}$
• Storage temperature	$T_{stg}$	-65 to +150	$^\circ\text{C}$

GaAs MMICs are ESD sensitive devices. Special handling precautions are required.

Sony reserves the right to change products and specifications without prior notice. This information does not convey any license by any implication or otherwise under any patents or other right. Application circuits shown, if any, are typical examples illustrating the operation of the devices. Sony cannot assume responsibility for any problems arising out of the use of these circuits.

**Pin Configuration**

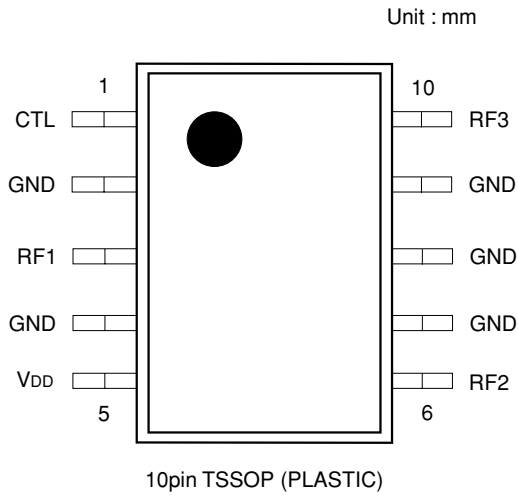

**Block Diagram**

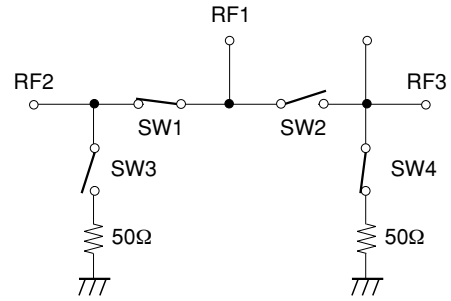

**Recommended Circuit**

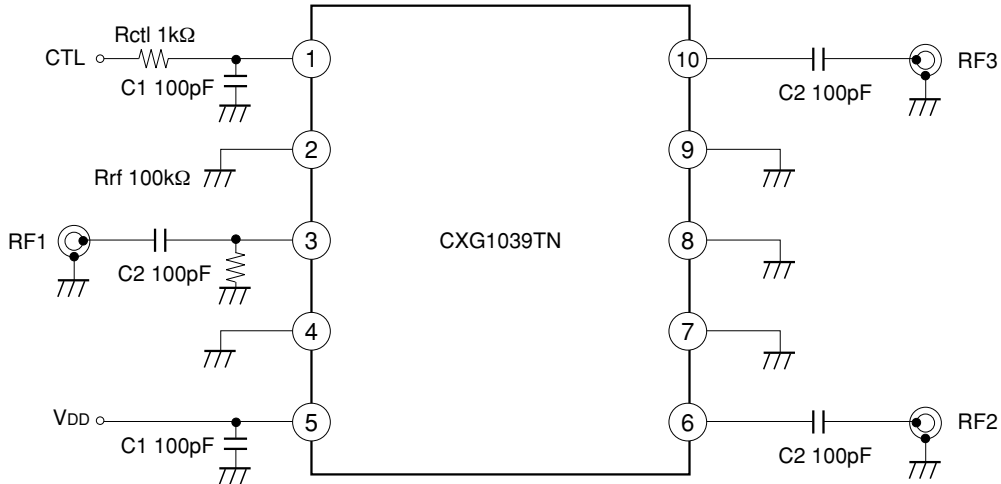

When using the CXG1039TN, the following external components should be used:

- C1: This is used for signal line filtering. 100 pF is recommended.
- C2: This is used for RF De-coupling and must be used in all applications. 100 pF is recommended.
- Rctl: This is used to give improved ESD performance.
- Rrf: This resistor is used to stabilize the dc operating point at high power levels. A value of 100 kΩ is recommended.

**Truth Table**

CTL		SW1	SW2	SW3	SW4
H	RF1 - RF2 ON	ON	OFF	OFF	ON
L	RF1 - RF3 ON	OFF	ON	ON	OFF

**Operating Condition**

(Ta=-35 °C to +85 °C)

	Symbol	Min.	Typ.	Max.	Unit.
Control voltage (High)	Vctl (H)	2.5		3.6	V
Control voltage (Low)	Vctl (L)	0		0.5	V
Bias voltage	V <sub>DD</sub>	2.7		4	V

**Electrical Characteristics (1)**V<sub>DD</sub>=3 V, V<sub>ctl</sub> (L)=0 V, V<sub>ctl</sub> (H)=2.8 V±3 %,

@2 GHz, Pin=10 dBm, Impedance at all ports : 50 Ω

(Ta=25 °C)

Item	Symbol	Min.	Typ.	Max.	Unit
Insertion loss	IL		0.8	1.2	dB
Isolation	ISO	40	50		dB
ON port VSWR	VSWR (ON)		1.2	1.5	
OFF port VSWR	VSWR (OFF)		1.7	2.0	
3rd order input intercept point *1	IP3	35			dBm
Input power for 1 dBm compression	P1dB	12	17		dBm
Switching speed	TSW		1	5	μs
Bias current	I <sub>DD</sub>		220	350	μA
Control current	ICRL		80	150	μA

\*1 two-tone input power up to 5 dBm

**Electrical Characteristics (2)**V<sub>DD</sub>=3 V, V<sub>ctl</sub> (L)=0 V, V<sub>ctl</sub> (H)=2.8 V±3 %,

@2 GHz, Pin=10 dBm, Impedance at all ports : 50 Ω

(Ta=-35 °C to +85 °C)

Item	Symbol	Min.	Typ.	Max.	Unit
Insertion loss	IL		0.8	1.4	dB
Isolation	ISO	40	50		dB
ON port VSWR	VSWR (ON)		1.2	1.5	
OFF port VSWR	VSWR (OFF)		1.7	2.0	
3rd order input intercept point *1	IP3	35			dBm
Input power for 1 dBm compression	P1dB	12	17		dBm
Switching speed	TSW		1	5	μs
Bias current	I <sub>DD</sub>		220	450	μA
Control current	ICRL		80	180	μA

\*1 two-tone input power up to 5 dBm

Package Outline Unit : mm

10PIN TSSOP(PLASTIC)

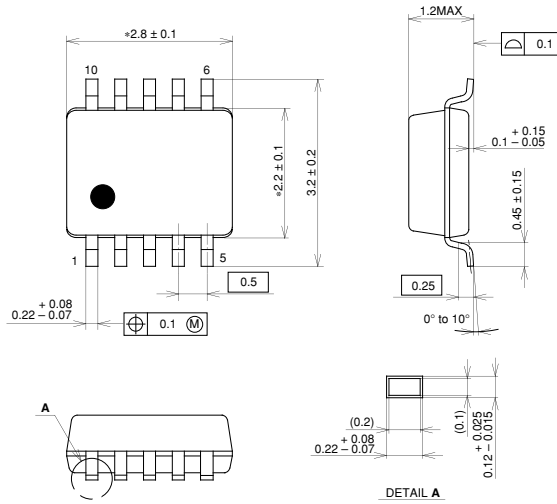

NOTE: Dimension "\*" does not include mold protrusion.

PACKAGE STRUCTURE

SONY CODE	TSSOP-10P-L01
EIAJ CODE	_____
JEDEC CODE	_____

PACKAGE MATERIAL	EPOXY RESIN
LEAD TREATMENT	SOLDER PLATING
LEAD MATERIAL	COPPER ALLOY
PACKAGE MASS	0.02g

10PIN TSSOP(PLASTIC)

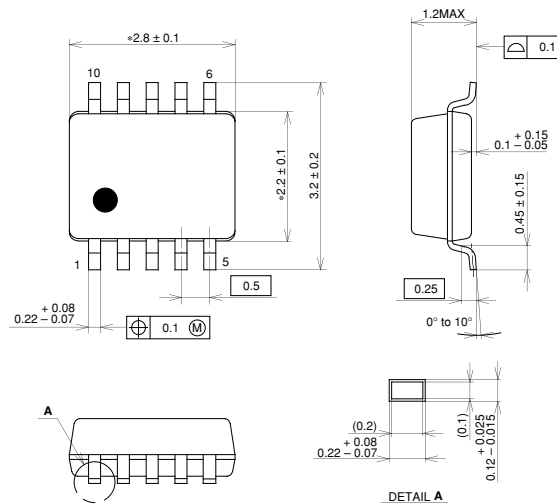

NOTE: Dimension "\*" does not include mold protrusion.

PACKAGE STRUCTURE

SONY CODE	TSSOP-10P-L01
EIAJ CODE	_____
JEDEC CODE	_____

PACKAGE MATERIAL	EPOXY RESIN
LEAD TREATMENT	SOLDER PLATING
LEAD MATERIAL	COPPER ALLOY
PACKAGE MASS	0.02g

LEAD PLATING SPECIFICATIONS

ITEM	SPEC.
LEAD MATERIAL	COPPER ALLOY
SOLDER COMPOSITION	Sn-Bi Bi:1-4wt%
PLATING THICKNESS	5-18µm