

CMOS 8-bit Single Chip Microcomputer

Description

The CXP82612/82616 microcomputer is composed of a CPU, ROM, RAM, and I/O ports. These chips feature many other high-performance circuits in a single-chip CMOS design, including an A/D converter, serial interface, timer/counter, time-base timer, fluorescent display controller/driver, remote control receiver and 32kHz timer/counter.

This device also includes a power-on reset function and sleep/stop functions which can be used to achieve low power consumption.

80 pin QFP (Plastic)

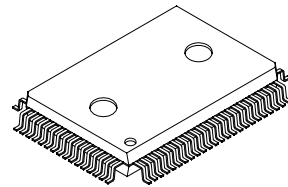

Features

- Instruction set which supports a wide array of data types
 - 213 types of instructions which include 16-bit calculations, multiplication and division arithmetic, and boolean bit operations.
- Minimum instruction cycle 400ns for 10MHz, 122 μ s/for 32kHz operation
- On-chip ROM 12K bytes (CXP82612)
16K bytes (CXP82616)
- On-chip RAM 448 bytes (Including fluorescent display data area)
- Peripheral functions
 - A/D converter 8-bit, 8-channel, successive approximation system (conversion rate 32 μ s/10MHz)
 - Serial interface On-chip 8-bit, 8-stage FIFO (1 to 8 bytes auto transfer),
1 circuit 2-channel
 - Timers 8-bit timer
8-bit timer/counter
19-bit time base timer
32kHz timer/counter
 - Fluorescent display controller/driver Maximum of 336 segments display available
1 to 16 digits dynamic display
Dimmer function
High voltage tolerance output (40V)
On-chip pull-down resistor (Mask option)
Hardware key scan function (Maximum of 8 \times 16 key matrix available)
 - Remote control receiver circuit On-chip 6 stage FIFO 8-bit pulse measurement counter
- Interrupts 13 factors, 13 vectors multi-interruption possible
- Standby mode Sleep/stop
- Package 80-pin plastic QFP
- Piggyback/evaluator CXP82600 80-pin ceramic QFP

Structure

Silicon gate CMOS IC

Sony reserves the right to change products and specifications without prior notice. This information does not convey any license by any implication or otherwise under any patents or other right. Application circuits shown, if any, are typical examples illustrating the operation of the devices. Sony cannot assume responsibility for any problems arising out of the use of these circuits.

Block Diagram

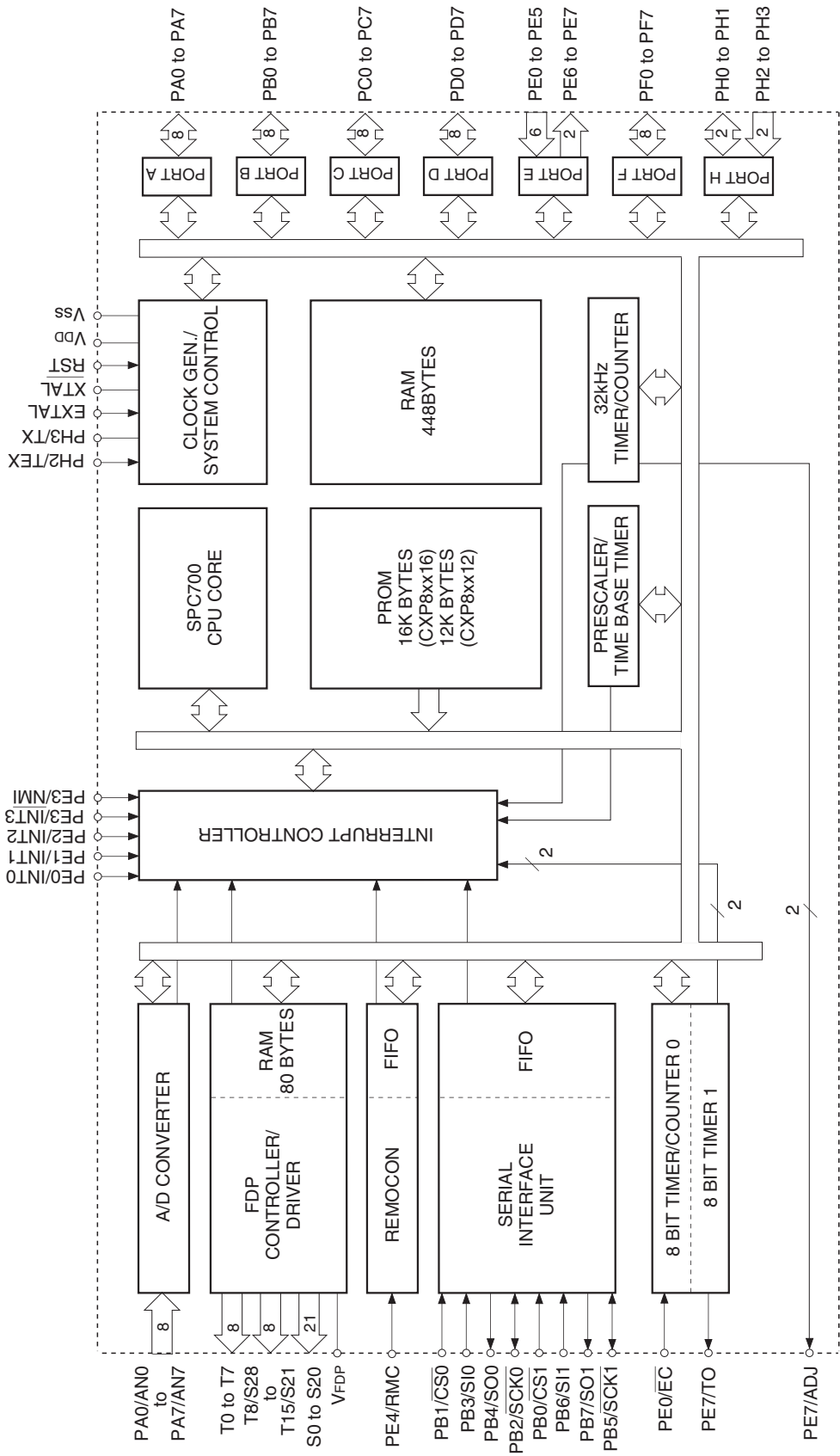

Pin Assignment (Top View)

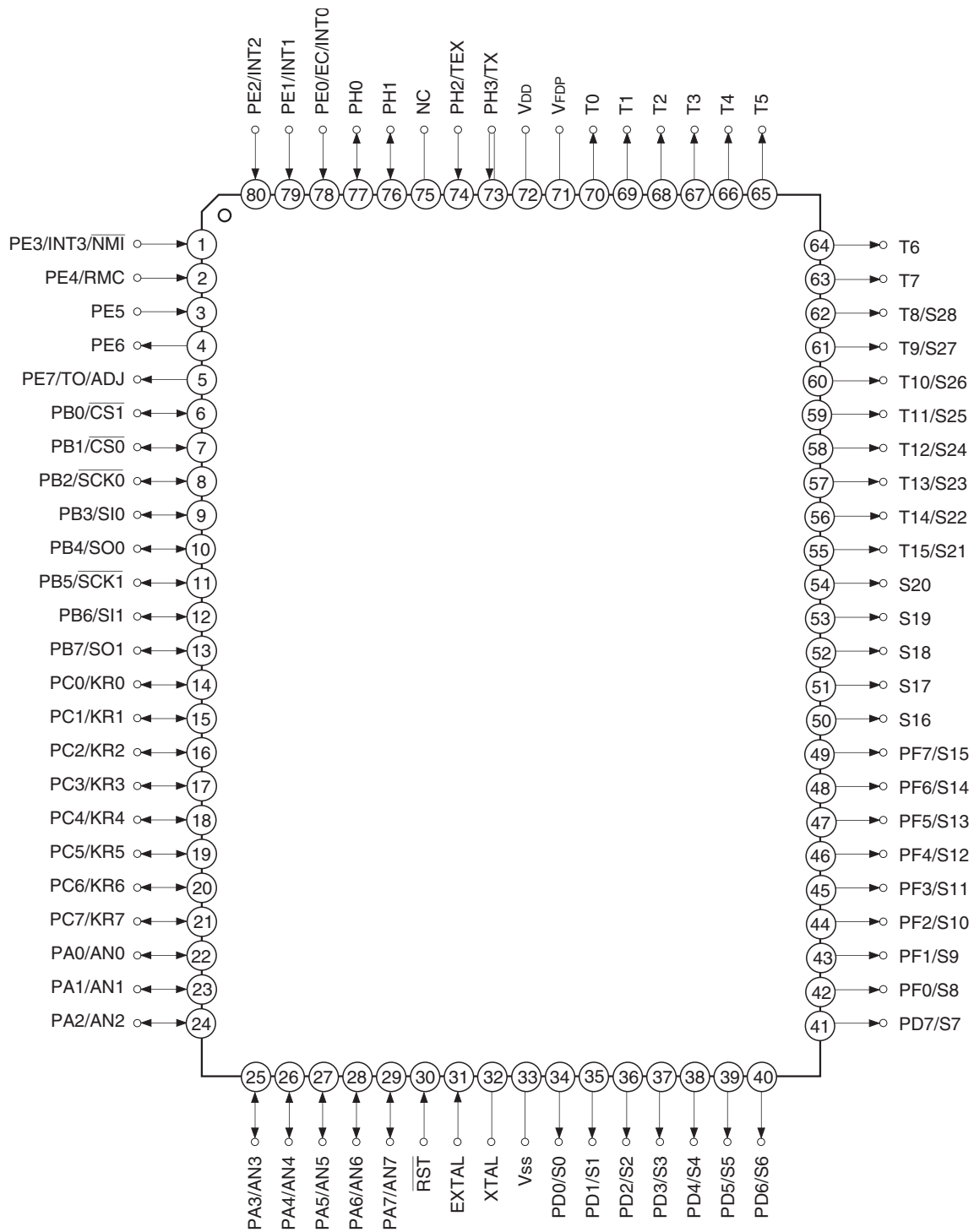

- Note)**
1. NC (Pin 75) is always connected to V_{DD}.
 2. PH3/TX (Pin 73) is input port during port selection;
oscillation output during oscillation selection

Pin Description

Symbol	I/O	Functions	
PA0/AN0 to PA7/AN7	I/O/Analog Input	(Port A) 8-bit I/O port. I/O can be set in a bit unit. Incorporation of pull-up resistor can be set through the software in a unit of 4 bits. (8 pins)	Analog inputs to A/D converter. (8 pins)
PB0/ $\overline{CS1}$	I/O/Input	(Port B) 8-bit I/O port. I/O can be set in a bit unit. Incorporation of pull-up resistor can be set through the software in a unit of 4 bits. (8 pins)	Chip select input for serial interface (CH1).
PB1/ $\overline{CS0}$	I/O/Input		Chip select input for serial interface (CH0).
PB2/ $\overline{SCK0}$	I/O/I/O		Serial clock I/O (CH0).
PB3/SI0	I/O/Input		Serial data input (CH0).
PB4/SO0	I/O/Output		Serial data output (CH0).
PB5/ $\overline{SCK1}$	I/O/I/O		Serial clock I/O (CH1).
PB6/SI1	I/O/Input		Serial data input (CH1).
PB7/SO1	I/O/Output		Serial data output (CH1).
PC0/KR0 to PC7/KR7	I/O/Input	(Port C) 8-bit I/O port. I/O can be set in a bit unit. Capable of driving 12mA sink current. Incorporation of pull-up resistor can be set through the software in a unit of 4 bits. (8 pins)	Key return input for FDP segment signal which performs key scanning.
PE0/INT0/ $\overline{EC0}$	Input/Input/ Input	(Port E) 8-bit port. Upper 6 bits are for inputs; lower 2 bits are for outputs. (8 pins)	External interrupt requests. (4 pins)
PE1/INT1	Input/Input		
PE2/INT2	Input/Input		Non-maskable interruption request input.
PE3/INT3/ \overline{NMI}	Input/Input/ Input		Input for remote control receiver circuit.
PE4/RMC	Input/Input		
PE5	Input		
PE6	Input		
PE7/TO/ ADJ	Output/Output		Output for timer/counter rectangular waveform and 32kHz oscillation frequency division.

Symbol	I/O	Functions	
PH0 to PH1	I/O	(Port H) 2-bit I/O port. I/O can be set in a bit unit. Incorporation of pull-up resistor can be set through the software in a unit of 2 bits. (2 pins)	
PF0/S8 to PF7/S15	Output/Output	(Port F) 8-bit output port. (8 pins)	Segment signal output for FDP.
S16 to S20	Output	Segment signal output for FDP.	
T8/S28 to T15/S21	Output/Output	Dual purpose output for FDP timing and segment signals.	
T0 to T7	Output	Timing signal output for FDP.	
PD0/S0 to PD7/S7	Output/Output	(Port D) 8-bit output port. (8 pins)	Segment signal output for FDP.
V _{FDP}		Provides voltage for FDP when on-chip resistor is selected under mask option.	
EXTAL	Input	Crystal connectors for system clock oscillation. When the clock is supplied externally, input to EXTAL; opposite phase clock should be input to XTAL.	
XTAL	Output		
PH2/TEX	Input/Input	(Port H) 2-bit input port. (2 pins)	Crystal connectors for 32kHz timer/counter clock oscillation circuit. Connect a 32kHz crystal oscillator between TEX and TX. For usage as event input, connect clock oscillation source to TEX, and leave TX open.
PH3/TX	Input/Output		
$\overline{\text{RST}}$	Input	Low-level active. System reset. $\overline{\text{RST}}$ is input pin.	
NC		NC. Under normal operating conditions, connect to V _{DD} .	
V _{DD}		V _{CC} supply.	
V _{SS}		GND	

I/O Circuit Format for Pins

Pin	Circuit format	When reset
<p>PA0/AN0 to PA7/AN7</p> <p>8 pins</p>	<p>Port A</p> <p>* Pull-up transistors approx. 100kΩ</p>	<p>Hi-Z</p>
<p>PB0/$\overline{\text{CS1}}$ PB1/$\overline{\text{CS0}}$ PB3/SI0 PB6/SI1</p> <p>4 pins</p>	<p>Port B</p> <p>* Pull-up transistors approx. 100kΩ</p> <p>SI0 and SI1 are not schmitt input.</p>	<p>Hi-Z</p>
<p>PB2/$\overline{\text{SCK0}}$ PB5/$\overline{\text{SCK1}}$</p> <p>2 pins</p>	<p>Port B</p> <p>* Pull-up transistors approx. 100kΩ</p>	<p>Hi-Z</p>

Pin	Circuit format	When reset
PB4/SO0 PB7/SO1 2 pins	<p> Pull-up resistor "0" when reset SO Output enable Port B output selection "0" when reset Port B data Port B direction "0" when reset Data bus RD (Port B) * Pull-up transistors approx. 100kΩ </p>	Hi-Z
PC0/KR0 to PC7/KR7 8 pins	<p> Pull-up resistor "0" when reset Port C data Port C direction "0" when reset Data bus RD (Port C) Key input signal *1 Large current drive of 12mA possible *2 Pull-up transistors approx. 100kΩ </p>	Hi-Z
PE0/ \overline{EC} /INT0 PE1/INT1 PE2/INT2 PE3/INT3/ \overline{NMI} PE4/RMC 5 pins	<p> Schmitt input IP \overline{EC}/INT0 INT1 INT2 INT3/\overline{NMI} RMC Data bus RD (Port E) </p>	Hi-Z
PE5 1 pin	<p> IP Data bus RD (Port E) </p>	Hi-Z
PE6 1 pin	<p> Port E data "1" when reset Data bus RD (Port E) </p>	High level

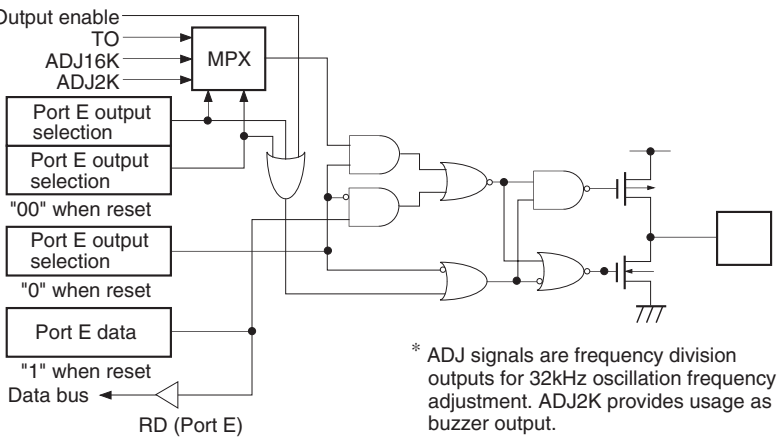
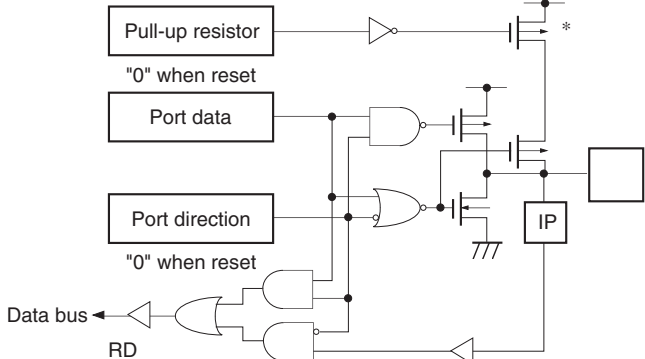
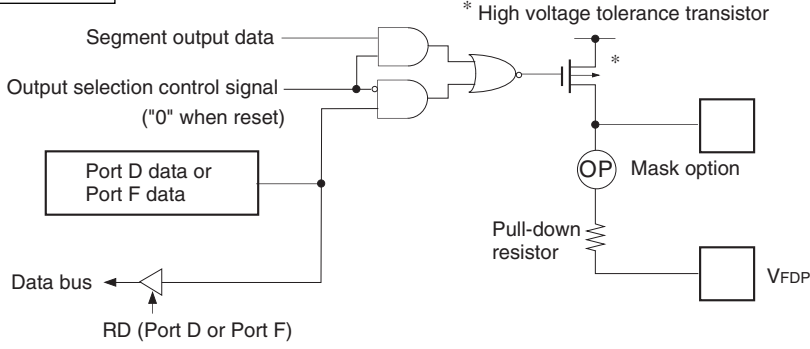
Pin	Circuit format	When reset
<p>PE7/TO/ADJ</p> <p>1 pin</p>	<p>Port E</p>  <p>* ADJ signals are frequency division outputs for 32kHz oscillation frequency adjustment. ADJ2K provides usage as buzzer output.</p>	<p>High level (High level with 150kΩ resistor when reset)</p>
<p>PH0 to PH1</p> <p>2 pins</p>	<p>Port H</p>  <p>* Pull-up transistors approx. 100kΩ</p>	<p>Hi-Z</p>
<p>PD0/S0 to PD7/S7</p> <p>PF0/S8 to PF7/S15</p> <p>16 pins</p>	<p>Port D</p> <p>Port F</p>  <p>* High voltage tolerance transistor</p> <p>Mask option</p> <p>V_{FDP}</p>	<p>Hi-Z or Low level (When PD resistor is connected)</p>

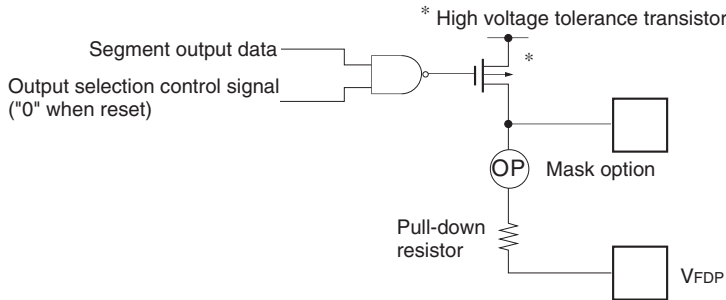
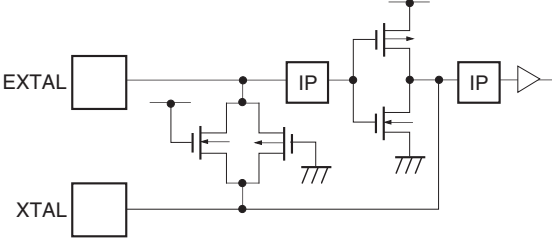
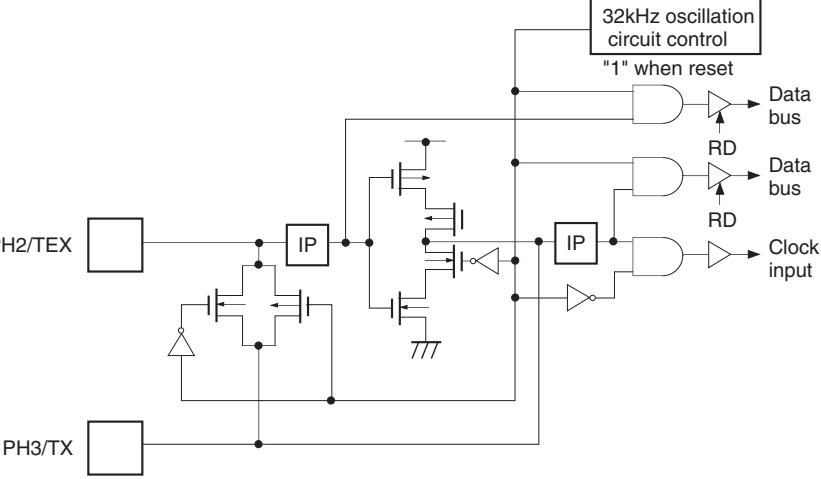
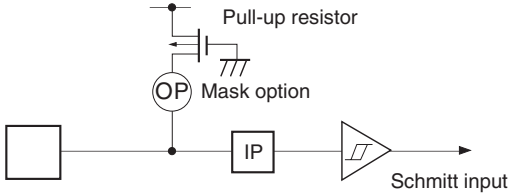
Pin	Circuit format	When reset
<p>S16 to S20 T15/S21 to T8/S28 T0 to T7</p> <p>21 pins</p>	 <p>* High voltage tolerance transistor</p> <p>Segment output data</p> <p>Output selection control signal ("0" when reset)</p> <p>Mask option</p> <p>Pull-down resistor</p> <p>V_{FDP}</p>	<p>Hi-Z or Low level (When PD resistor is connected)</p>
<p>EXTAL XTAL</p> <p>2 pins</p>	 <ul style="list-style-type: none"> • Diagram shows circuit construction for oscillation. • During STOP feedback resistor is disconnected. 	<p>Oscillation</p>
<p>PH2/TEX PH3/TX</p> <p>2 pins</p>	 <p>32kHz oscillation circuit control "1" when reset</p> <p>PH2/TEX</p> <p>PH3/TX</p> <p>Data bus</p> <p>RD</p> <p>Data bus</p> <p>RD</p> <p>Clock input</p>	<p>Oscillation halted port input</p>
<p>$\overline{\text{RST}}$</p> <p>1 pin</p>	 <p>Pull-up resistor</p> <p>Mask option</p> <p>Schmitt input</p>	<p>High level</p>

Absolute Maximum Ratings

(V_{SS} = 0V)

Item	Symbol	Rating	Unit	Remarks
Supply voltage	V _{DD}	-0.3 to +7.0	V	
Input voltage	V _{IN}	-0.3 to +7.0* ¹	V	
Output voltage	V _{OUT}	-0.3 to +7.0* ¹	V	
Display output voltage	V _{OD}	V _{DD} - 40 to V _{DD} + 0.3	V	As P channel transistor is open drain, V _{DD} voltage is determined as standard.
High level output current	I _{OH}	-5	mA	Other than display output pins* ² : per pin
	I _{ODH1}	-15	mA	Display output S0 to S20: per pin
	I _{ODH2}	-35	mA	Display output T0 to T7 T8/S28 to T15/S21: per pin
High level total output current	∑I _{OH}	-40	mA	Total of other than display output pins
	∑I _{ODH}	-100	mA	Total of display output pins
Low level output current	I _{OL}	15	mA	Port 1 pin
	I _{OLC}	20	mA	Large current port pin* ³
Low level total output current	∑I _{OL}	100	mA	Entire pin total
Operating temperature	T _{opr}	-20 to +75	°C	
Storage temperature	T _{stg}	-55 to +150	°C	
Allowable power dissipation	P _D	600	mW	

*¹ V_{IN} and V_{OUT} must not exceed V_{DD} + 0.3V.

*² Specifies output current of general-purpose I/O ports.

*³ The large current drive transistor is an N-ch transistor of Port C (PC).

Note) If the absolute maximum ratings are exceeded, the LSI could reach permanent breakdown. Also, observing recommended operating conditions is desirable; otherwise, the LSI's reliability could be affected.

Recommended Operating Conditions

(V_{SS} = 0V)

Item	Symbol	Min.	Max.	Unit	Remarks
Supply voltage	V _{DD}	4.5	5.5	V	High speed mode (1/2, 1/4 clock) guaranteed operation range
		3.5	5.5	V	Low speed mode (1/16 clock) guaranteed operation range
		2.7	5.5	V	Guaranteed operation range with TEX clock
		2.5	5.5	V	Guaranteed data hold operation range during stop
High level input voltage	V _{IH}	0.7V _{DD}	V _{DD}	V	*1
	V _{IHS}	0.8V _{DD}	V _{DD}	V	Hysteresis input*2
	V _{IHEX}	V _{DD} - 0.4	V _{DD} + 0.3	V	EXTAL pin*3
Low level input voltage	V _{IL}	0	0.3V _{DD}	V	*1
	V _{ILS}	0	0.2V _{DD}	V	Hysteresis input*2
	V _{ILEX}	-0.3	0.4	V	EXTAL pin*3
Operating temperature	T _{opr}	-20	+75	°C	

*1 All regular input port (PA, PB3, PB4, PB6, PB7, PC, PE5, PH).

*2 For pins $\overline{\text{RST}}$, $\overline{\text{CS0}}$, $\overline{\text{CS1}}$, $\overline{\text{SCK0}}$, $\overline{\text{SCK1}}$, $\overline{\text{EC/INT0}}$, INT1, INT2, INT3/ $\overline{\text{NMI}}$, RMC.

*3 Specifies only for external clock input.

Electrical Characteristics

DC Characteristics

(Ta = -20 to +75°C, Vss = 0V)

Item	Symbol	Pin	Condition	Min.	Typ.	Max.	Unit
High level output voltage	V _{OH}	PA, PB, PC, PE6, PE7, PH0, PH1	V _{DD} = 4.5V, I _{OH} = -0.5mA	4.0			V
			V _{DD} = 4.5V, I _{OH} = -1.2mA	3.5			V
Low level output voltage	V _{OL}	PA, PB, PC, PE6, PE7, PH0, PH1	V _{DD} = 4.5V, I _{OL} = 1.8mA			0.4	V
			V _{DD} = 4.5V, I _{OL} = 3.6mA			0.6	V
		PC	V _{DD} = 4.5V, I _{OL} = 12.0mA			1.5	V
Input current	I _{IHE}	EXTAL	V _{DD} = 5.5V, V _{IH} = 5.5V	0.5		40	μA
	I _{ILE}		V _{DD} = 5.5V, V _{IL} = 0.4V	-0.5		-40	μA
	I _{IHT}	TEX	V _{DD} = 5.5V, V _{IL} = 5.5V	0.1		10	μA
	I _{ILT}		V _{DD} = 5.5V, V _{IL} = 0.4V	-0.1		-10	μA
	I _{ILR}	$\overline{\text{RST}}^{*1}$	V _{DD} = 5.5V, V _{IL} = 0.4V	-1.5		-400	μA
	I _{IL}	PA to PC* ² , PH0* ² , PH1* ²		-3.3		-50	μA
Display output current	I _{OH}	S0 to S20	V _{DD} = 4.5V V _{OH} = V _{DD} - 2.5V	-8			mA
		S21/T15 to S28/T8 T0 to T7		-20			mA
Open drain output leak current (P-CH Tr off state)	I _{LOL}	S0 to S20 S21/T15 to S28/T8 T0 to T7	V _{DD} = 5.5V V _{OL} = V _{DD} - 35V V _{FDP} = V _{DD} - 35V			-20	μA
Pull down resistor* ³	R _L	S0 to S20 S21/T15 to S28/T8 T0 to T7	V _{DD} = 5V V _{OD} - V _{FDP} = 30V	60	100	270	kΩ
Input/Output leak current	I _{Iz}	PA to PC* ² , PH0* ² , PH1* ² , $\overline{\text{RST}}^{*2}$	V _{DD} = 5.5V V _I = 0, 5.5V			±10	μA

Item	Symbol	Pin	Codition	Min.	Typ.	Max.	Unit
Supply current*4	I _{DD1}	V _{DD}	High-speed mode operation (1/2 frequency divider clock)		20	40	mA
			V _{DD} = 5.5V, 10MHz crystal oscillation (C ₁ = C ₂ = 15pF)				
	I _{DD2}		V _{DD} = 3V, 32kHz crystal oscillation (C ₁ = C ₂ = 47pF)		35	100	μA
	I _{DDS1}		Sleep mode		1.2	8	mA
			V _{DD} = 5.5V, 10MHz crystal oscillation (C ₁ = C ₂ = 15pF)				
	I _{DDS2}		V _{DD} = 3V, 32kHz crystal oscillation (C ₁ = C ₂ = 47pF)		9	30	μA
I _{DDS3}	Stop mode V _{DD} = 5.5V, termination of 32kHz and 10MHz crystal oscillation.				30	μA	
Input capacitance	C _{IN}	For pins other than S0 to S28, T0 to T7, PE6, PE7, V _{DD} , V _{SS} , V _{FDP}	1MHz clock 0V other than the measured pins		10	20	pF

- *1 $\overline{\text{RST}}$ specifies the input current when pull-up resistor has been selected; leakage current when no resistor has been selected.
- *2 Pins PA to PC, PH0, and PH1 specifies the input current when pull-up resistor has been selected; leakage current when no resistor has been selected.
- *3 Applies when the on-chip pull-down resistor is selected under the mask option.
- *4 All output pins are left open.

AC Characteristics

(1) Clock timing

(Ta = -20 to +75°C, VDD = 4.5 to 5.5V, VSS = 0V)

Item	Symbol	Pins	Conditions	Min.	Typ.	Max.	Unit
System clock frequency	fc	XTAL EXTAL	Fig. 1, Fig. 2	1		10	MHz
System clock input pulse width	t _{XL} , t _{XH}	EXTAL	Fig. 1, Fig. 2 External clock drive	37.5			ns
System clock input rise and fall time	t _{CR} , t _{CF}	EXTAL	Fig. 1, Fig. 2 External clock drive			200	ns
Event count input clock pulse width	t _{EH} , t _{EL}	\overline{EC}	Fig. 3	t _{sys} + 50*			ns
Event count input clock rise and fall time	t _{ER} , t _{EF}	\overline{EC}	Fig. 3			20	ms
System clock frequency	fc	TEX TX	V _{DD} = 2.7 to 5.5V Fig. 2 (32kHz clock applied condition)		32.768		kHz
Event count input clock input pulse width	t _{TL} , t _{TH}	TEX	Fig. 3	10			μs
Event count input clock rise and fall time	t _{TR} , t _{TF}	TEX	Fig. 3			20	ms

* t_{sys} indicates the three values below according to the upper two bits (CPU clock selection) of the clock control register (address: 00FEH).

t_{sys} [ns] = 2000/fc (upper two bits = "00"), 4000/fc (upper two bits = "01"), 16000/fc (upper two bits = "11")

Fig. 1. Clock timing

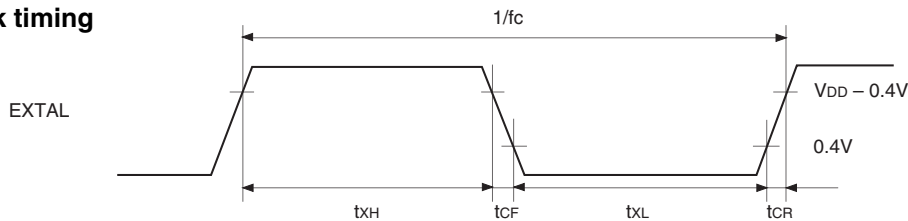

Fig. 2. Clock applied conditions

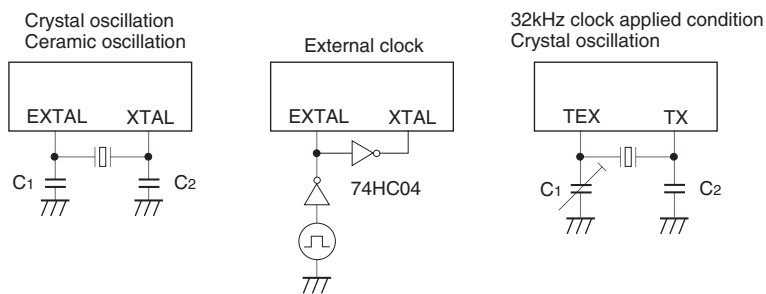
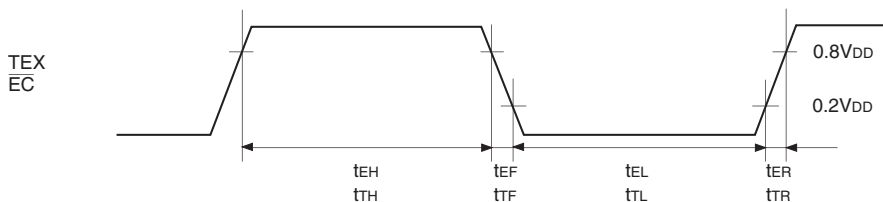

Fig. 3. Event count clock timing



(2) Serial transfer

(Ta = -20 to +75°C, VDD = 4.5 to 5.5V, VSS = 0V)

Item	Symbol	Pin	Condition	Min.	Max.	Unit
$\overline{CS0} \downarrow \rightarrow \overline{SCK0}$ ($\overline{CS1} \downarrow \rightarrow \overline{SCK1}$) delay time	t _{DCSK}	$\overline{SCK0}$ ($\overline{SCK1}$)	Chip select transfer mode ($\overline{SCK0}$ ($\overline{SCK1}$) = output mode)		t _{sys} + 200	ns
$\overline{CS0} \uparrow \rightarrow \overline{SCK0}$ ($\overline{CS1} \uparrow \rightarrow \overline{SCK1}$) float delay time	t _{DCSKF}	$\overline{SCK0}$ ($\overline{SCK1}$)	Chip select transfer mode ($\overline{SCK0}$ ($\overline{SCK1}$) = output mode)		t _{sys} + 200	ns
$\overline{CS0} \downarrow \rightarrow SO0$ ($\overline{CS1} \downarrow \rightarrow SO1$) delay time	t _{DCSO}	SO0 (SO1)	Chip select transfer mode		t _{sys} + 200	ns
$\overline{CS0} \uparrow \rightarrow SO0$ ($\overline{CS1} \uparrow \rightarrow SO1$) float delay time	t _{DCSOF}	SO0 (SO1)	Chip select transfer mode		t _{sys} + 200	ns
$\overline{CS0}$ ($\overline{CS1}$) high level width	t _{WHCS}	$\overline{CS0}$ ($\overline{CS1}$)	Chip select transfer mode	t _{sys} + 200		ns
$\overline{SCK0}$ ($\overline{SCK1}$) cycle time	t _{KCY}	$\overline{SCK0}$ ($\overline{SCK1}$)	Input mode	2t _{sys} + 200		ns
			Output mode	16000/fc		ns
$\overline{SCK0}$ ($\overline{SCK1}$) high and low level widths	t _{KH} t _{KL}	$\overline{SCK0}$ ($\overline{SCK1}$)	Input mode	t _{sys} + 100		ns
			Output mode	8000/fc - 50		ns
SI0 (SI1) input setup time (for $\overline{SCK0} \uparrow$ ($\overline{SCK1} \uparrow$))	t _{SIK}	SI0 (SI1)	$\overline{SCK0}$ ($\overline{SCK1}$) input mode	100		ns
			$\overline{SCK0}$ ($\overline{SCK1}$) output mode	200		ns
SI0 (SI1) input hold time (for $\overline{SCK0} \uparrow$ ($\overline{SCK1} \uparrow$))	t _{KSI}	SI0 (SI1)	$\overline{SCK0}$ ($\overline{SCK1}$) input mode	t _{sys} + 200		ns
			$\overline{SCK0}$ ($\overline{SCK1}$) output mode	100		ns
$\overline{SCK0} \downarrow \rightarrow SO0$ ($\overline{SCK1} \downarrow \rightarrow SO1$) delay time	t _{KSO}	SO0 (SO1)	$\overline{SCK0}$ ($\overline{SCK1}$) input mode		t _{sys} + 200	ns
			$\overline{SCK0}$ ($\overline{SCK1}$) output mode		100	ns

Note 1) t_{sys} indicates the three values below according to the upper two bits (CPU clock selection) of the control register clock (address: 00FEH).

t_{sys} [ns] = 2000/fc (upper two bits = "00"), 4000/fc (upper two bits = "01"), 16000/fc (upper two bits = "11")

Note 2) The load condition for the $\overline{SCK0}$ ($\overline{SCK1}$) output mode, SO0 (SO1) output delay time is 50pF + 1TTL.

Fig. 4. Serial transfer CH0 timing

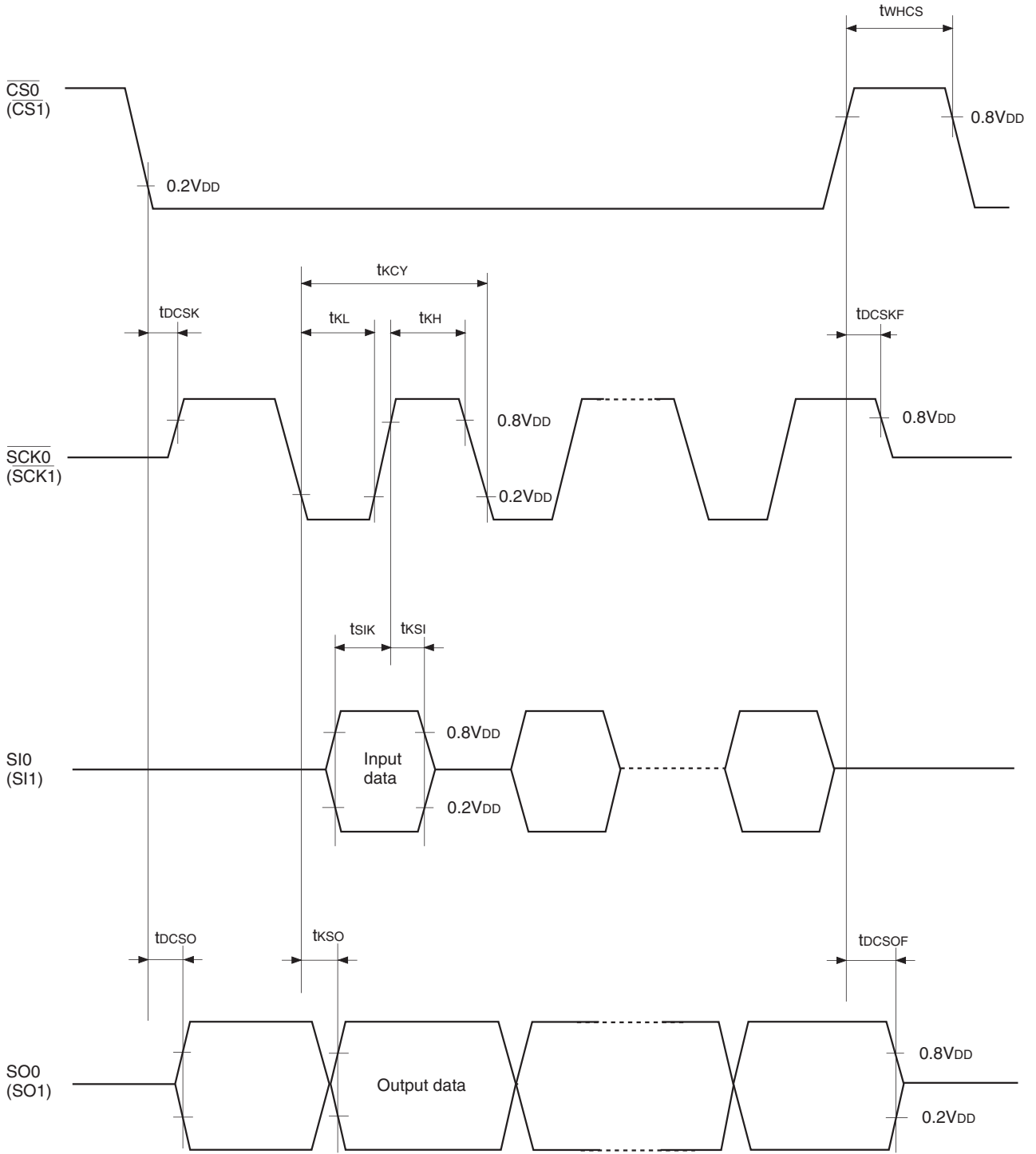

(3) A/D converter characteristics (Ta = -20 to +75°C, VDD = 4.5 to 5.5V, AVREF = 4.0 to AVDD, VSS = 0V)

Item	Symbol	Pin	Condition	Min.	Typ.	Max.	Unit
Resolution						8	Bits
Linearity error			Ta = 25°C VDD = 5.0V VSS = 0V			±3	LSB
Zero transition voltage	VZT*1			-10	-70	150	mV
Full-scale transition voltage	VFT*2			4930	5050	5120	mV
Conversion time	tCONV			160/fADC*3			µs
Sampling time	tSAMP			12/fADC*3			µs
Analog input voltage	VIAN	AN0 to AN7		0		AVREF	V

Fig. 5. Definition of A/D converter terms

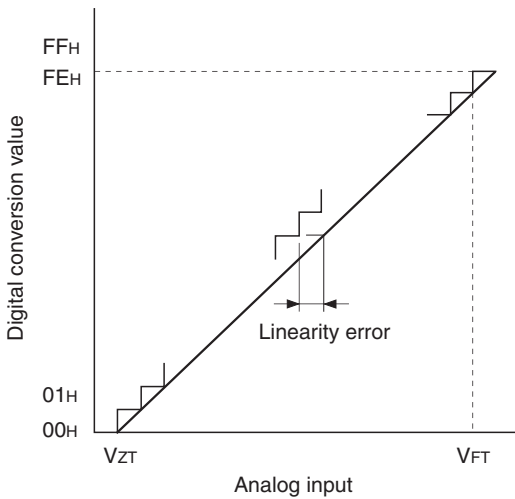

- *1 VZT : Value at which the digital conversion value changes from 00H to 01H and vice versa.
- *2 VFT : Value at which the digital conversion value changes from FEH to FFH and vice versa.
- *3 fADC indicates the below values due to the bit6 (CKS) of A/D control register (address: 00F9H) and the Bit7 (PCK1) and Bit6 (PCK0) of clock control register (address: 00FEH)

PCK1, 0	CKS	
	0 (φ/2 selection)	1 (φ selection)
00 (φ = fEX/2)	fADC = fc/2	fADC = fc
01 (φ = fEX/4)	fADC = fc/4	fADC = fc/2
11 (φ = fEX/16)	fADC = fc/16	fADC = fc/8

(4) Interruption, reset input (Ta = -20 to +75°C, VDD = 4.5 to 5.5V, VSS = 0V)

Item	Symbol	Pin	Condition	Min.	Max.	Unit
External interruption high and low level widths	t _{IH} t _{IL}	INT0 INT1 INT2 INT3 $\overline{\text{NMI}}$		1		μs
Reset input low level width	t _{RSL}	$\overline{\text{RST}}$		32/fc		μs

Fig 6. Interruption input timing

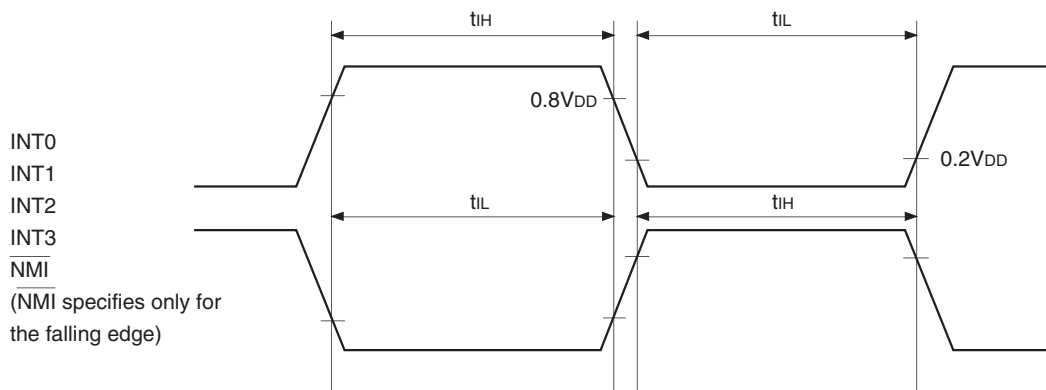
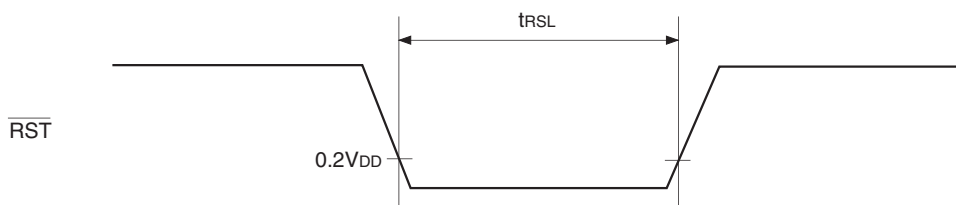
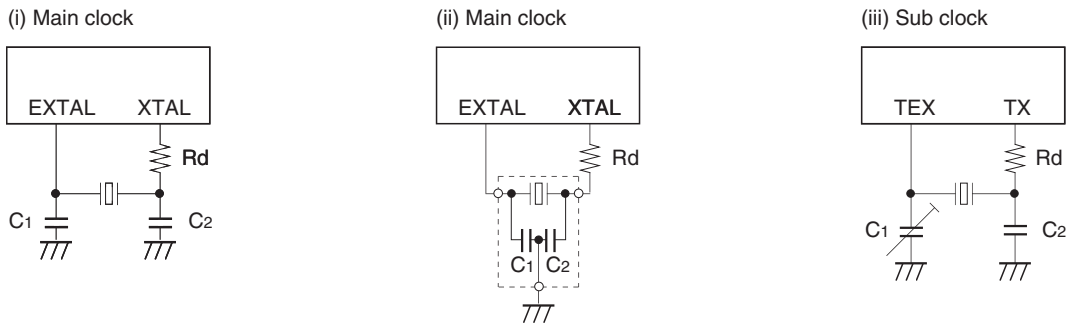

Fig. 7. $\overline{\text{RST}}$ input timing



Appendix

Fig. 8. Recommended oscillation circuit



Manufacturer	Model	fc (MHz)	C1 (pF)	C2 (pF)	Rd (Ω)	Circuit example
MURATA MFG CO., LTD.	CSA4.19MG	4.19	30	30	0	(i)
	CSA8.00MTZ	8.00				
	CSA10.0MTZ	10.00				
	CST4.19MGW*	4.19				(ii)
	CST8.00MTW*	8.00				
	CST10.0MTW*	10.00				
RIVER ELETEC CORPORATION	HC-49/U03	4.19	12	12	0	(i)
		8.00				
		10.00				
KINSEKI LTD.	HC-49/U (-S)	4.19	27	27	0	
		8.00				
		10.00	20	20		
	P3	32.768kHz	50	22	1M	(iii)

Those marked with an asterisk (*) signify types with built-in ground capacitance (C1, C2).

Mask Option Table

Item	Content	
Reset pin pull-up resistor	Non-existent	Existent
High voltage tolerance pull-down resistor	Non-existent	Existent (selected every pin)

Characteristics Curves

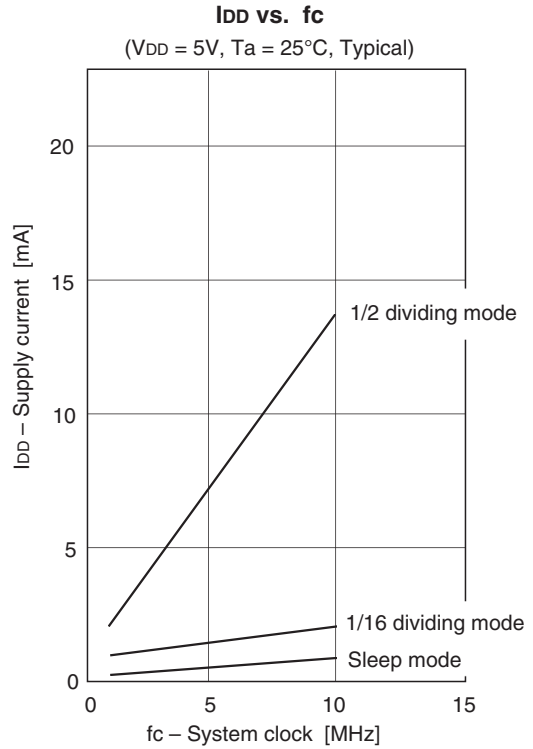
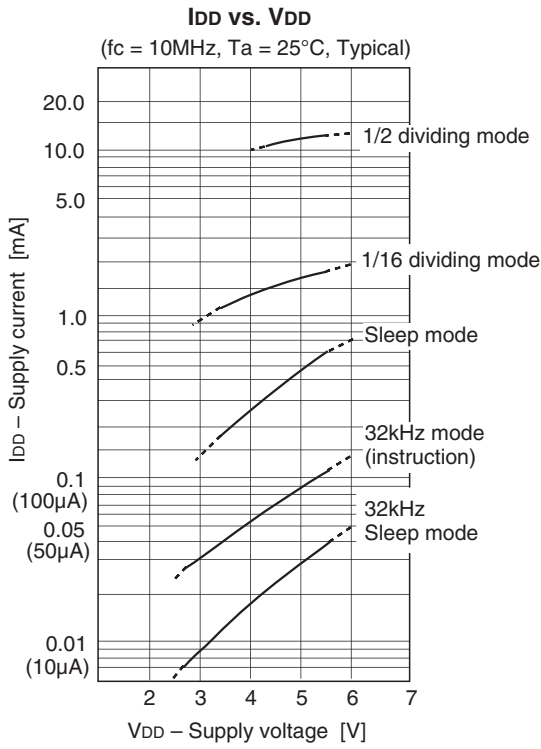

Package Outline

Unit : mm

80PIN QFP (PLASTIC)

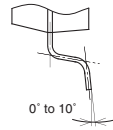
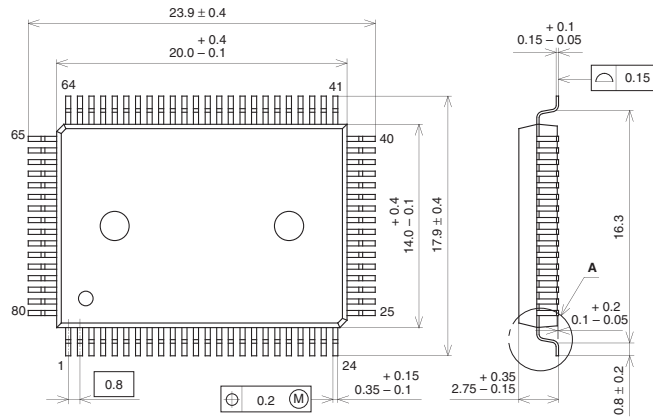

DETAIL A

SONY CODE	QFP-80P-L01
EIAJ CODE	QFP080-P-1420
JEDEC CODE	

PACKAGE STRUCTURE

PACKAGE MATERIAL	EPOXY RESIN
LEAD TREATMENT	SOLDER PLATING
LEAD MATERIAL	42/COPPER ALLOY
PACKAGE MASS	1.6g

80PIN QFP (PLASTIC)

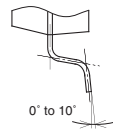
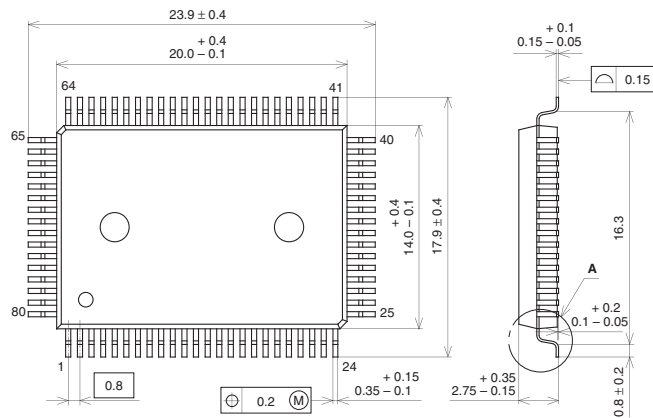

DETAIL A

SONY CODE	QFP-80P-L01
EIAJ CODE	QFP080-P-1420
JEDEC CODE	

PACKAGE STRUCTURE

PACKAGE MATERIAL	EPOXY RESIN
LEAD TREATMENT	SOLDER PLATING
LEAD MATERIAL	42/COPPER ALLOY
PACKAGE MASS	1.6g

LEAD PLATING SPECIFICATIONS

ITEM	SPEC.
LEAD MATERIAL	42 ALLOY
SOLDER COMPOSITION	Sn-Bi Bi:1-4wt%
PLATING THICKNESS	5-18µm