

CXD5148GG, Analog Front End IC and Camera System IC CXD4140GG for Security Cameras



* "ARM" is a trademark of ARM Limited.

Sony has developed the CXD5148GG, a new analog front end (AFE) IC, and the CXD4140GG, an "Enhanced Effio-E" IC, both for security camera application.

The CXD5148GG has been developed as a common*¹ AFE for the "Effio" series enabling the sharing of boards for greater user friendliness.

The CXD4140GG "Enhanced Effio-E" is an improved version of the CXD4127GG "Effio-E" *² and also provides a new infrared LED exposure optimization function and capability to customize part of the On Screen Display (OSD) menu.

*¹: The article provides details on compatible products.

*²: See the New Products section in CX-NEWS, Volume 61.

CXD5148GG

- Use of common boards
- Striving for greater ease of use

"Enhanced Effio-E" CXD4140GG

- Function for optimizing exposure for infrared LEDs
- Some OSD menu functions can be customized

Effio™

* "Effio" is a trademark of Sony Corporation. The "Effio" is a signal processor chip from Sony employing processing modes that deliver high resolution, high S/N ratio and excellent color reproduction.

Use of Common Boards

The CXD5148GG is an AFE for CCD image sensors equipped with a CDS, a timing generator and V and H drivers.

The new product supports a wide range of driving frequencies as well as single and double exposure operating systems to enable connection to all CCD image sensors used by the System IC "Effio" series for security cameras.

The CXD5148GG camera IC supports the newly added "Enhanced Effio-E" (CXD4140GG) as well as the "Effio-P" (CXD4129GG)*³ and the "Effio-S" (CXD4130GG)*³. (See figure 1.)

The "Effio" series required that either the CXD4813GG or the CXD4816GG*² AFE be

used depending on the CCD image sensor and the system IC. The CXD5148GG allows use of common boards simplifying the configuration of camera lineups.

*³: See the New Products section in CX-NEWS, Volume 63.

Striving for Greater Ease of Use

The CXD5148GG provides greater performance than the current Sony products while also streamlining board design.

Optimization of pin functions that reduce pin numbers, the adoption of a new generation of processing technology and turning high-voltage processes into a single chip have all helped to lower power consumption. (See table 2.)

Like the current Sony products, the CXD5148GG can obtain the required power supply voltages from outside by the integration of an LDO to handle the multiple supply voltages that the adoption of a new generation of processing technology requires.

Processing technology and hardware circuit design have removed the restrictions in supplying power to components requiring different voltages, for example, between 1.8 V and 3.3 V systems and between V_H and V_L thereby simplifying the design of power supplies and reset circuits for camera systems.

Function for Optimizing Exposure for Infrared LEDs

"Enhanced Effio-E" (CXD4140GG) is an improved version of "Effio-E."
The new product comes with a function for

optimizing exposure under infrared LED illumination to make it compatible with the currently popular infrared LED security cameras.

This function ensures correct exposure and increases visibility by preventing the overexposure that the excessive front lighting of a highly directional infrared LED light source often causes during nighttime photography. (See photograph 1.)

Some OSD Menu Functions can be Customized

The OSD for setting up the camera consisted of a fixed menu in "Effio-E" that could not be customized. For a greater ease of use, some OSD menu functions can now be customized by the user.

This new capability allows customers to edit the menu structure and function names that appear to suit camera specifications. (See table 1.)

V O I C E

We were able to integrate two types of AFEs to maintain connectivity with a lot of CCD image sensors and multiple chips and cut no corners in ensuring that the new product delivered better performance than current products.

Sony has already received inquiries from many customers.

We are confident that the new AFEs, the "CXD5148GG" and the "Effio" series, are the best choice you can make.

Figure 1 "Enhanced Effio-E" System Configuration

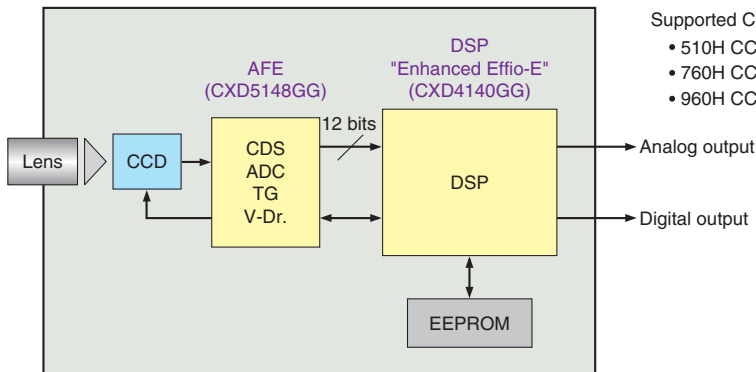

Supported CCD image sensors

- 510H CCD (Type 1/3, Type 1/4 NTSC/PAL)
- 760H CCD (Type 1/2, Type 1/3, Type 1/4 NTSC/PAL)
- 960H CCD (Type 1/3, Type 1/4 NTSC/PAL)

* CCD = CCD image sensor

* The CXD5148GG are also connected to "Effio-P" or "Effio-S".

Photograph 1 Infrared LED Exposure Optimization Function Sample Images

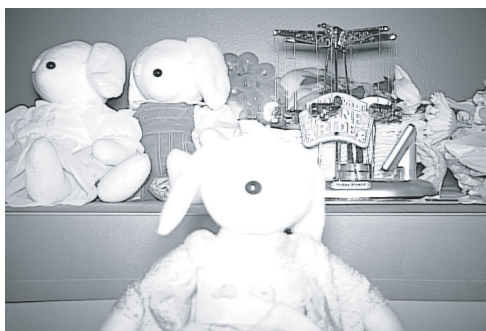

Infrared LED exposure optimization function: off

Infrared LED exposure optimization function: on

Table 1 Main "Enhanced Effio-E" System Specifications

Item	"Enhanced Effio-E" system	
Supported CCDs	510H, 760H, 960H CCDs	
System configuration	2 chips (DSP/AFE)	
Functions	Resolution	Over 650 TV lines (horizontal)
	ATR	✓
	Noise reduction	2D-NR
	Day & night	(infrared LED exposure optimization)
	Privacy mask	8 marks
	HLC	✓
	AF detector	✓
	Motion detection	✓
	OSD	Multiple language support, fixed menus (some menu functions can be customized)
	Port driver	16 ports
Outputs	Analog outputs	Y/C separate, composite
	Digital outputs	ITU-R BT.656 standard output (27MHz), CCD image size (CCD drive frequency)
	Dual analog and digital outputs	✓
Supply voltages	CXD5148GG: 3.3 V, V _H , V _L CXD4140GG: 3.3 V, 1.2 V	
Packages	CXD5148GG: 64-pin LFBGA CXD4140GG: 97-pin LFBGA	

* CCD = CCD image sensor

Table 2 AFE Comparison

Item	CXD5148GG	CXD4813GG	CXD4816GG
Number of pins	64 pins	96 pins	80 pins
Package size	7 mm × 7 mm	8 mm × 8 mm	7 mm × 7 mm
Power consumption	370 mW@36 MHz 175 mW@18 MHz	560 mW@36 MHz	225 mW@18 MHz