

CXG1400XR, CXG1405XR

Antenna Tuning Switchable Step Capacitor GaAs MMIC

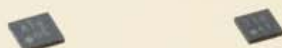

Sony's antenna switches achieve low insertion loss and high linearity due to Sony's unique JPHEMT*¹ process technology. Sony has now developed the CXG1400XR and CXG1405XR switchable step capacitor (SSC) products that allow capacitor switching by integrating capacitors in the same device. These SSC devices implement high-precision capacitors with high Q values. The inclusion of capacitors means that mounting and changing capacitors are not required during evaluation. Furthermore, these devices can contribute to reducing mounting areas and can be used in a variety of applications, including "FeliCa*²" antenna tuning in cellular phones.

*¹ JPHEMT: Junction Gate Pseudomorphic High Electron Mobility Transistor

*² "FeliCa" is a contactless IC card technology developed by Sony Corporation. "FeliCa" is a trademark of Sony Corporation.

- Low pass-through loss, high linearity
Pass-through characteristics:
0.30 dB @900 MHz,
0.2 dB @13.56 MHz (RF-GND6)
Harmonic characteristics:
2fo: 72 dBc @900 MHz,
3fo: 66 dBc @900 MHz (RF-GND6)

- Built-in high Q, high-precision capacitors: Capacitor tolerance: within $\pm 7\%$.

- Miniature, low-profile package:
2.3 mm \times 2.3 mm \times 0.35 mm (CXG1400XR)
2.0 mm \times 2.0 mm \times 0.35 mm (CXG1405XR)

- Logic signal control of antenna tuning
Adjustment from 1 to 31 pF in 1 pF steps (CXG1400XR)
Adjustment from 1 to 7 pF in 1 pF steps (CXG1405XR)*³

*³: This device also supports adjustment from 0.5 to 7.5 pF in 0.5 pF steps.

Low Pass-Through Loss, High Linearity

The Sony CXG1400XR and CXG1405XR switching blocks are fabricated in Sony's unique JPHEMT process, to achieve low pass-through loss. (See table 1.) Since the switching block is seen as a pass-through loss when a capacitor is selected, the capacitor's Q value will influence the

loss. Therefore, achieving a high Q value in the capacitor is effective for achieving a low pass-through loss.

Another issue here is that "FeliCa" adopts a modulation technique that uses comparatively high voltage amplitudes. These products use Sony's high linearity technology developed for cellular phone antenna switches, and achieve excellent communication characteristics even when used in "FeliCa" applications.

Built-in High Q, High-Precision Capacitors

Sony's MIMC* technology is used for the built-in capacitors. By using thick-film plating layering technology on a GaAs substrate, Sony achieved high-precision capacitor with high Q values. Also, since all the capacitors in each path have the same sample-to-sample variation characteristics, they are appropriate for adjustment using bit control. (See table 1.)

* MIMC: Metal-Insulator-Metal Capacitor

Miniature, Low-Profile Package

The CXG1400XR is provided in a XQFN miniature, low-profile package. (See figure 2a.) This results in a significantly reduced mounting area compared to using external capacitors, since the capacitors are integrated in the package. (See figure 2b.)

The CXG1405XR adopts an even more miniaturized package with a size of 2.0 \times 2.0 mm. (See figure 2a.)

Logic Signal Control of Antenna Tuning

Figure 3 presents an example of practical "FeliCa" antenna impedance matching. The CXG1400XR and CXG1405XR adopt a control method that differs from ordinary antenna switches. In particular, CTL pins are allocated to each path. This allows the creation of a synthesized capacitance to optimize the antenna impedance. (See figure 4.)

The CXG1400XR allows the capacitance to be adjusted over a 1 to 31 pF range in 1 pF steps, and the CXG1405XR allows the capacitance to be adjusted in 0.5 pF steps. (See table 2.)

V O I C E

The newly-developed CXG1400XR and CXG1405XR introduced here are designed for the completely new application of antenna tuning, and as such, differ from earlier antenna switches. The CXG1400XR was designed for "FeliCa" antenna tuning and has already been used in cellular phone products. Of course, it can also be used for applications other than "FeliCa". We are currently designing a wide variety of other antenna tuning SSC products, and I strongly recommend that anyone interested in this area contact Sony for more information.

Table 1 Main Characteristics

CXG1400XR Electrical Characteristics

Item	Symbol	Path	Condition	Typ.	Unit
Transmission performance	S21	RF-GND1	*1	38.5	dB
			*2	5.4	
		RF-GND2	*1	34	
			*2	3.0	
		RF-GND3	*1	28	
			*2	1.3	
		RF-GND4	*1	22	
			*2	0.7	
		RF-GND5	*1	17	
			*2	0.45	
		RF-GND6	*1	0.2	
			*2	0.3	
Isolation	ISO	RF-GND1	*2	20	dB
		RF-GND2	*2	20	
		RF-GND3	*2	20	
		RF-GND4	*2	20	
		RF-GND5	*2	20	
		RF-GND6	*2	20	
Harmonics	2fo	RF-GND5	*3	72	dBc
		RF-GND5	*3	66	
	3fo	RF-GND5	*3	72	
		RF-GND6	*3	66	
Ictl	Ictl	CTL = ALL_H	Pin = 27 dBm	1.85	μA
			Pin = 0 dBm	1.80	

CXG1405XR Electrical Characteristics

Item	Symbol	Path	Condition	Typ.	Unit
Transmission performance	S21	RF-GND1	*1	39	dB
			*2	5.8	
		RF-GND2	*1	35	
			*2	2.8	
		RF-GND3	*1	29	
			*2	1.4	
		RF-GND4	*1	0.2	
			*2	0.3	
Isolation	ISO	RF-GND1	*2	21	dB
		RF-GND2	*2	20	
		RF-GND3	*2	20	
		RF-GND4	*2	21	
Harmonics	2fo	RF-GND4	*3	72	dBc
			*3	66	
Ictl	Ictl	CTL = ALL_H	Pin = 27 dBm	1.6	μA
			Pin = 0 dBm	1.6	

*1 Pin = 0 dBm, frequency = 13.56 MHz
 *2 Pin = 0 dBm, frequency = 900 MHz
 *3 Pin = 27 dBm, frequency = 900 MHz

Figure 1 Block Diagram

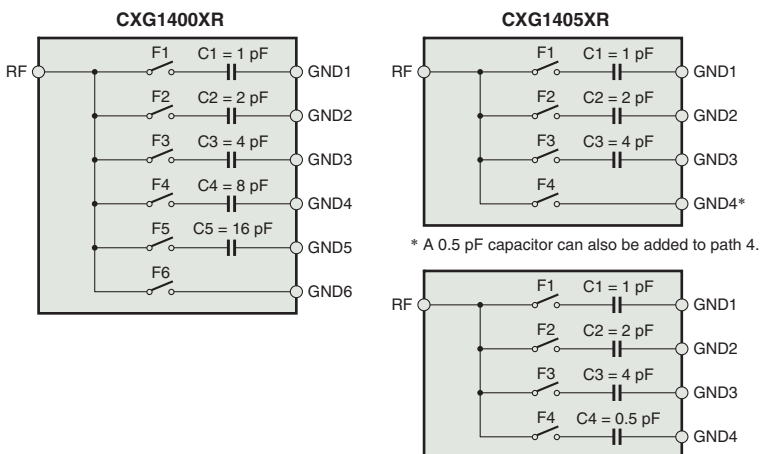

Table 2 Control Logic Truth Table

CXG1400XR

State	CTLA	CTLB	CTLC	CTLD	CTLE	Capacitor
1	H	L	L	L	L	1 pF
2	L	H	L	L	L	2 pF
3	H	H	L	L	L	3 pF
4	L	L	H	L	L	4 pF
:	:	:	:	:	:	:
31	H	H	H	H	H	31 pF

CXG1405XR (When path 4 is 0.5 pF)

State	CTLA	CTLB	CTLC	CTLD	Capacitor
1	L	L	L	H	0.5 pF
2	H	L	L	L	1 pF
3	H	L	L	H	1.5 pF
4	L	H	L	L	2 pF
:	:	:	:	:	:
15	H	H	H	H	7.5 pF

Figure 2a External Dimensions

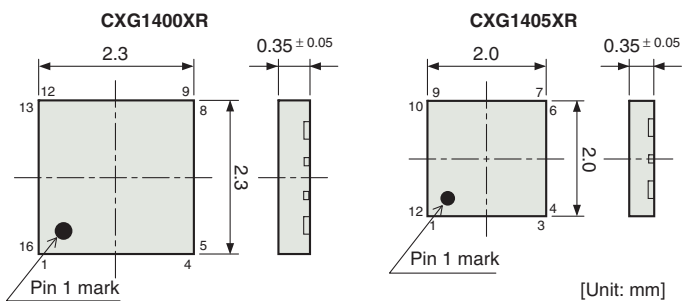

Figure 2b Mounting Area Comparison (With Other Sony Products)

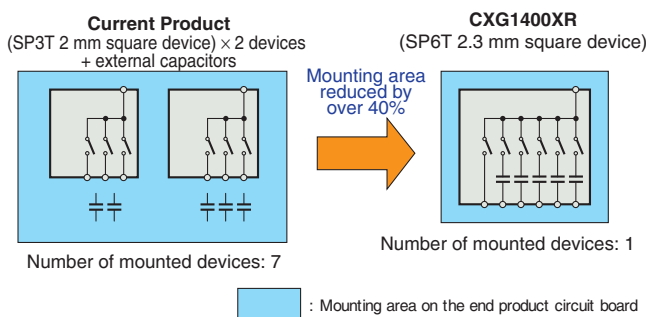

Figure 3 Application Example (FeliCa antenna impedance matching)

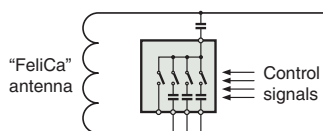

Figure 4 SSC-Based Tuning Concepts

