

# CXD2817R

## Cable and Terrestrial TV Digital Broadcast Demodulator IC Achieves the Industry's Top Class Performance



The newly-developed Sony CXD2817R is a multi-format demodulator IC that supports both DVB-T (Digital Video Broadcast - Terrestrial) and DVB-C (Digital Video Broadcast - Cable). This IC achieves, in a single chip, both space savings and high performance. The CXD2817R receives an IF signal from the tuner and provides a demodulated output in the TS format. It conforms to both the ETSI EN 300 744 (terrestrial digital broadcasting) and ETSI EN 300 429 (digital cable broadcasting) standards.

- Implements both DVB-T and DVB-C demodulation in a single chip
- Demodulating algorithms that are highly resistant to multipath interference
- Improved adjacent channel interference rejection
- Extensive set of built-in functions, including automatic control functions
- Supports both normal IF and low-IF tuners
- Low power consumption  
DVB-T reception: 115 mW (Typ.)  
DVB-C reception: 105 mW (Typ.)

### Implements both DVB-T and DVB-C Demodulation in a Single Chip

The CXD2817R is a multi-format demodulator IC that supports both DVB-T (the terrestrial digital broadcast standard) and DVB-C (the digital cable broadcast standard). While Sony led the industry in developing the first device that integrated both DVB-T and DVB-C demodulation functions on a single chip, Sony has achieved both significant performance improvements and added functionality in the CXD2817R. Figure 1 shows the block diagram of the CXD2817R. It is provided in a  $7 \times 7 \text{ mm}^2$  48-pin LQFP package.

### Demodulating Algorithms that are Highly Resistant to Multipath Interference

algorithms that are highly resistant to multipath interference and can handle a variety of situations, including the transition

from the cessation of analog terrestrial broadcasting to digital broadcasting and the wide range of multipath environments expected due to the changes in the broadcast waveform environment due to the start of DVB-T2 broadcasting. In particular, the CXD2817R is extremely resistant even to multipath that crosses over a guard interval, which until now has been thought to be difficult to handle, and it can be applied flexibly to SFN (Single-Frequency Network) broadcasting, which is likely to be more widely deployed in future. (See figure 2.)

### Improved Adjacent Channel Interference Rejection

The CXD2817R prevents aliasing of adjacent channel signals into the desired band due to the sampling theorem and A/D conversion by using a higher A/D converter sampling frequency than existing models. This has improved the adjacent channel interference rejection characteristics. (See figure 3.) Not only the CNR, which is a basic characteristic, but also the impulse noise resistance, which is expected to be standardized in the future, and the CCI (co-channel interference) resistance have been significantly improved.

### Extensive Set of Built-in Functions, Including Automatic Control Functions

The CXD2817R also provides an automatic recovery function that performs demodulation synchronization control in the IC itself and functions that support automatic detection of spectrum inversions for use in each of the DVB-T and DVB-C modes. These make software development even easier. The CXD2817R also makes even more accurate monitoring of the received signal strength possible by adding a 10-bit A/D converter for signal strength monitoring.

### Support for a Wide Variety of Interfaces

The CXD2817R supports reception using either a normal IF (DVB-T: 36.166 MHz, DVB-C: 36.125 MHz) or a low-IF (about 5 MHz). It can also flexibly support a wide variety of output formats, including TS output as well as both serial and parallel outputs. Since register settings and other aspects are optimized assuming use with a Sony silicon tuner IC, it can be used in end products with only a minimal number of register settings.

### Low Power Consumption

In combination with its high functionality, the CXD2817R also supports low power consumption applications. In particular, it achieves the low power of 115 mW (typ.) in DVB-T mode and 105 mW (typ.) in DVB-C mode. Furthermore, power consumption can be reduced to under 15 mW in sleep mode, in which only the tuner control functions remain active, and to under 0.15 mW in shutdown mode, in which the crystal oscillator is stopped.

## V O I C E

In developing this device, we took great pains to assure that the great ideas of the development team would actually lead to improved user satisfaction. Thanks to the cooperation of both our customers and the related divisions within Sony, we were able to establish both the "needs" and the "seeds", and this resulted in what is, I think, a truly great IC. I am looking forward to working with everyone who has read this article to aim for the creation of even better televisions.

**Figure 1** Block Diagram

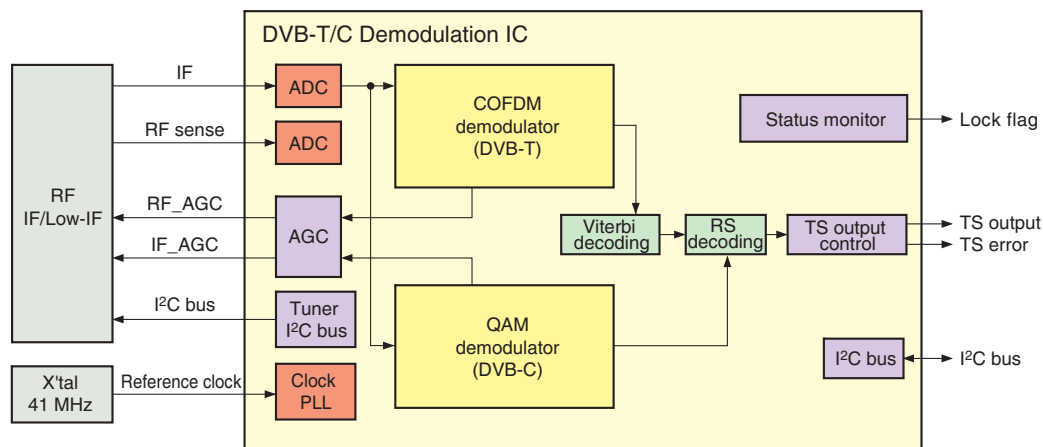

**Figure 2** Introduction to SFN and Comparison of Performance Outside the Guard Interval

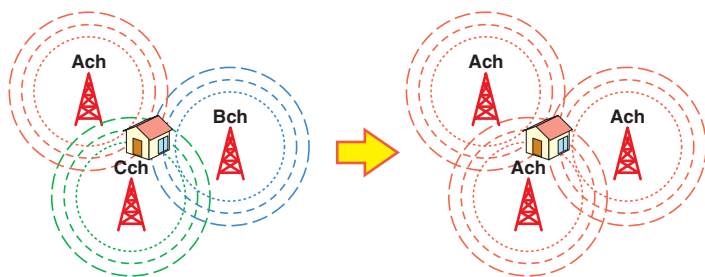

**MFN (Multi-Frequency Network) Scheme**

Each broadcast tower broadcasts on a different frequency. Although multipath is not a problem, the frequency utilization efficiency is poor.

**SFN (Single-Frequency Network) Scheme**

Each broadcast tower broadcasts on the same frequency. Although the frequency utilization efficiency is good, workarounds for multipath interference are required.

TASK\_3\_30 C/(N+I) Performance in Single Frequency Networks inside the guard interval  
666 MHz 64QAM CR = 2/3 GI = 1/8

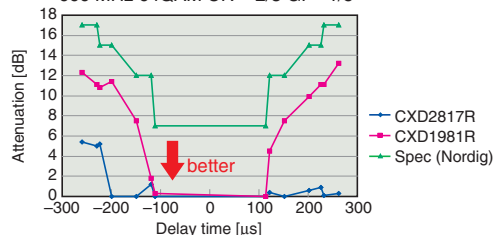

Performance has been significantly improved for multipath outside the guard interval, allowing this IC to respond flexibly to changes in signal specifications even after the transition to SFN.

**Figure 3** A/D Converter Countermeasures for Adjacent Channel Interference

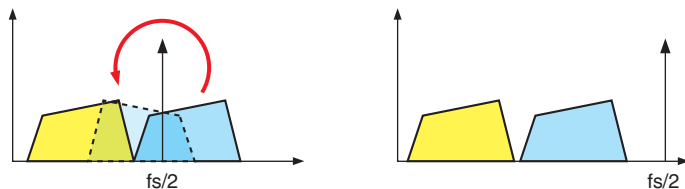

**Current Products (sampling frequency  $f_s = 20.5$  MHz)**

According to the sampling theorem, frequencies higher than  $f_s/2$  (10.24 MHz) are aliased to lower frequencies and appear as interference in the desired band.

**CXD2817R (sampling frequency  $f_s = 41$  MHz)**

Since  $f_s/2$  is 20.5 MHz, the adjacent waveforms are sampled correctly by the A/D converter. As a result, adjacent waveforms are not aliased into the desired band. The adjacent waveforms are excluded in the signal after conversion to a digital signal.

TASK\_3\_23 Immunity to "Analog" Signals in Other Channels  
666 MHz 64QAM CR = 3/4 GI = 1/4

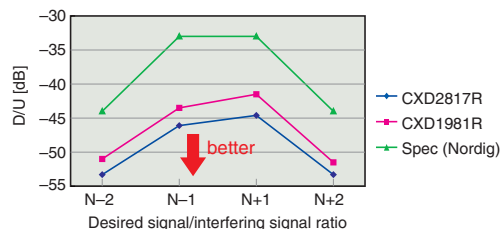

Compared to current methods, resistance to adjacent channel interference is improved significantly.