

CXA2239R

Sony has been increasing the performance and functionality of their video switch products to match the increasing picture quality of video sources (such as composite signals, component signals, and even HD signals) in the TV market. In addition to integrating the next-stage A/D converter's low-pass filter (60 MHz) in the same package, the CXA2239R introduced here achieves the ability to support both full high definition (1080p) signals and wideband RGB signals. Furthermore, since it is important to recognize the standard of the input signal for the image processing performed by the end product, the CXA2239R also includes a signal standard discrimination circuit.

In addition, this IC supports S, D, and SCART connectors, and can be used anywhere in the world.

- Maximum 2.8 Vp-p video signal output
- Main screen system switch frequency response: 60 MHz flat output
- Built-in low-pass filters (7, 14, 30, and 60 MHz)
- Supports S, D, and SCART connectors
- Format detection function
- Built-in sync separator circuit

■ Video Switch that Supports TV, HDTV, and PC Signals Integrated on a Single Chip

The signals used in TVs are becoming increasingly diverse along with the increasing screen sizes and higher picture quality in recent TVs. This has led to demands for video switches that can handle TV signals. The CXA2239R can output these TV signals (1080p) with a flat frequency response up to 60 MHz for video signals up to 2.8 Vp-p. The CXA2239R also incorporates switching functions for PC signals that were previously controlled with other dedicated ICs. Thus the CXA2239R achieves single-chip integration of video switching functions for not only TV signals, but PC signals as well.

■ Built-in 75Ω Driver

Prior to the CXA2239R, an external 75Ω driver was required for the TV output connector (MONOUT). By integrating this driver on the same chip, the CXA2239R reduces the number of external components required and has evolved to a video switch that makes end product design even easier.

■ Built-in Low-Pass Filter

Prior to the CXA2239R, low-pass filters for the A/D converter at the following stage were required for each output connector. The CXA2239R not only integrates 7, 14, and 30 MHz low-pass filters on the same chip, it also includes a 60 MHz low-pass filter as well to support signal standards up to full HD.

■ Sync Separation and Format Detection for All Existing Signal Standards

The CXA2239R provides sync separation and format detection for all signal standards from existing analog connector inputs (composite video connector, S-connector, component video connector, D-connector, SCART connector, and 5-wire RGBHV inputs). By setting the post-switching operational amplifier slew rate to be 50 [μs/V], the CXA2239R maintains a sync width that can support format detection even for 1080p/60 (sync width: 0.3 μs), which is the standard for which format detection is the most difficult for existing sync separator ICs, thus assuring that sync separation is possible.

V O I C E

The CXA2239R was developed based on the concept of supporting all worldwide broadcast standards. By combining the strengths of all the members of the development team, we were able to develop a chip that not only provides many functions, but also achieves characteristics that will satisfy our customers' needs. I strongly suggest that you look into this device to see how attractive it can be for your products.

■ A Video Switch that Provides Worldwide Support

The CXA2239R adds a shared function to the S connector detection circuit that is included in existing switches and can also provide SCART connector detection, which is increasingly popular in Europe. This allows products that use the CXA2239R to enter the European market.

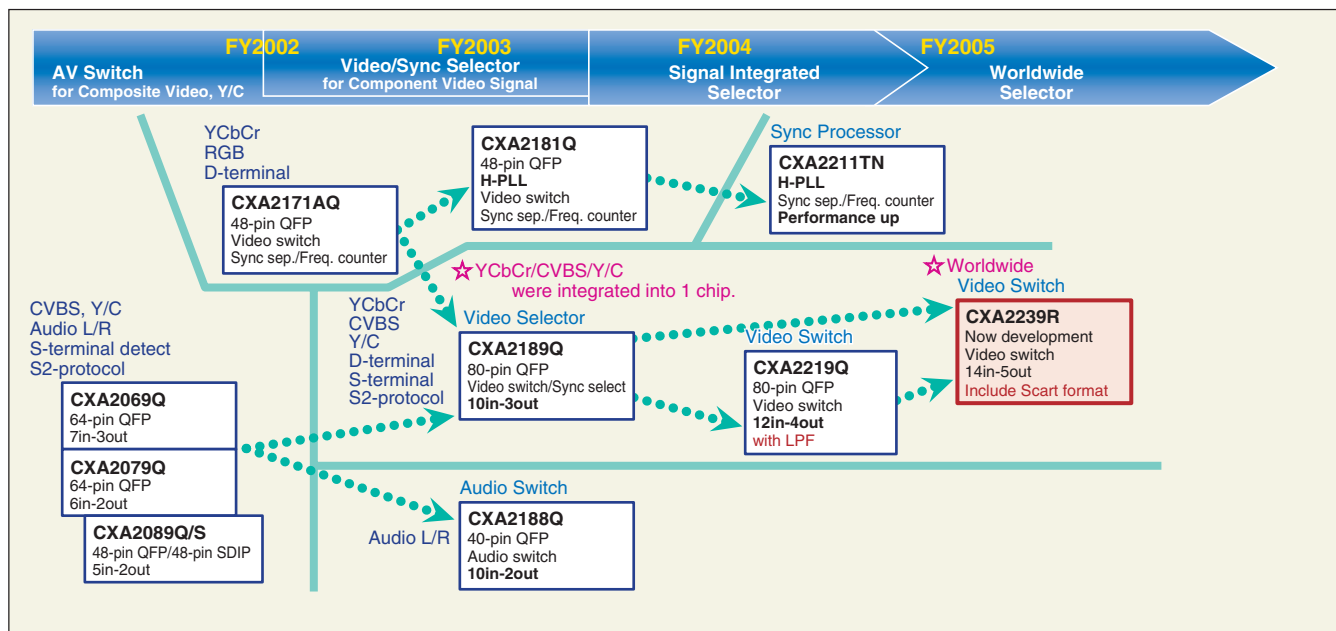

■ Figure 1 Product Roadmap

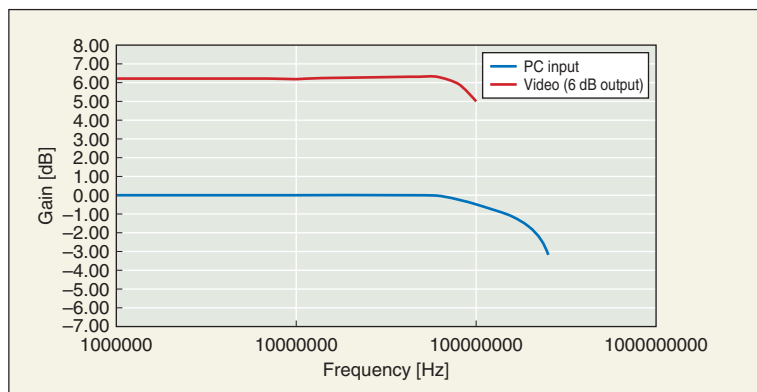

■ Figure 2 Frequency Response

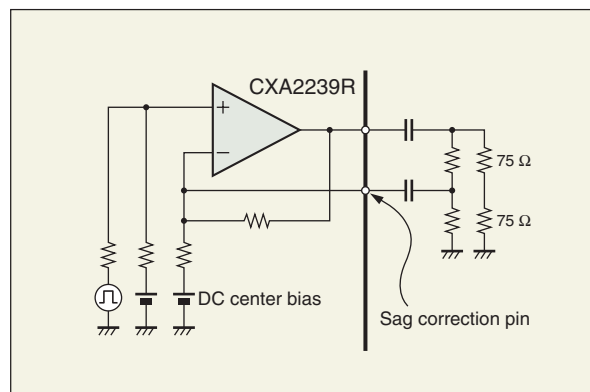

■ Figure 3 75Ω Driver Block Diagram

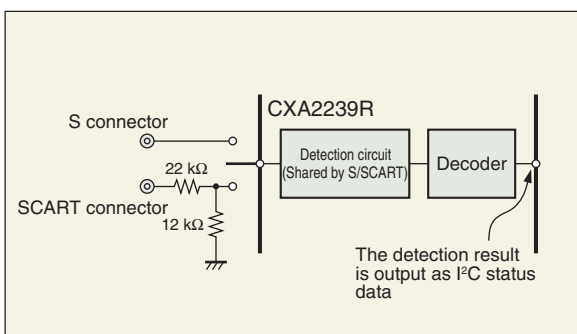

■ Figure 4 S/SCART Connector Detection

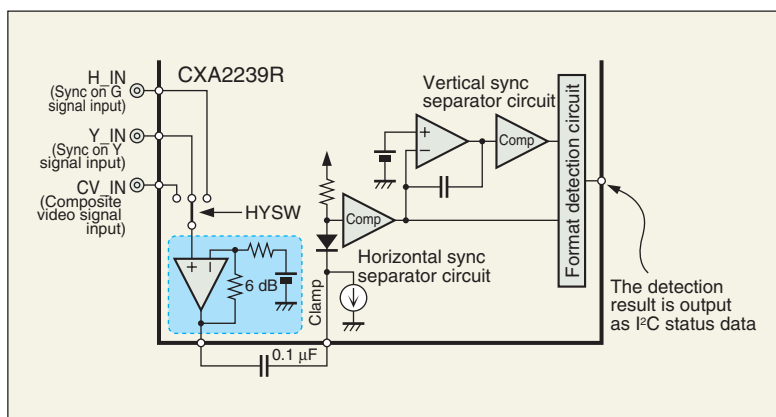

■ Figure 5 Sync Separation and Format Detection Block Diagram