

# Ultrahigh Power Infrared Array Laser Diode Achieves 60 W Optical Power Output

## SLD433S4

Ultrahigh power infrared laser diodes are widely used in welding equipment, all types of marking equipment, and as the pumping light source for YAG lasers.

The evolution of this continually advancing industrial equipment knows no bounds, and requires ultrahigh power laser diodes with even higher reliability.

Sony is listening to the needs of this market, and continues to develop even higher output and even higher performance laser diodes.

Now, following on the success of the 40 W optical power output SLD432S, Sony has developed the SLD433S4 60W optical power output array laser diode that features the even higher output and the ability to be used in a wide range of applications.

- Wavelength: 808  $\pm$ 3 nm
- Rated optical power output: 60 W, CW operation
- High reliability
- Low operating current

### ■ Newly-Developed Water Cooled Heat Sink Provides High Heat Removal Efficiency

Sony developed and released the SLD431S and SLD432S to respond to the market needs for even higher output in ultrahigh power array laser diodes. However, increasing the power even further in array laser diodes results in the generation of more heat as well. This generated heat determines the upper limit of optical power output of the device and can reduce reliability. To resolve this problem Sony developed a new heat sink that is not a

conventional passive heat sink, but rather is a water cooled design with high heat removal capacity. Using this water cooled heat sink to remove heat guarantees high reliability in the SLD433S4 even at the optical power output of 60 W. The SLD433S4 also features greatly improved optical power output dependence of wavelength. This features can provide optimal pumping light source for YAG lasers.

### ■ Ultrahigh Power Laser Diode with High Reliability

The newly-developed SLD433S4 adopts the same stripe structure as the proven high-reliability, low operating current SLD431 series products. (See figure 1.) Additional improvements make this new device provide a 60 W optical power output. (See figure 2 and table 1.) The package adopts a newly-developed water cooled heat sink (see figure 3) and assures even higher reliability. Sony can also respond to customer needs for module versions of this device.

### ■ Support for Wavelength Selection

This device is available in the pumping YAG laser wavelength of 808  $\pm$ 3 nm as a general-purpose product. Sony can also respond to customer needs for other 800 nm range wavelength.

## V O I C E

Our development of infrared array laser diodes has progressed to the point where we have now achieved the industry's highest level: 60 W. That we were able to achieve this high output level demonstrates the extremely high reliability of Sony's single-stripe ultrahigh power laser diodes. I am looking forward to developing new products with even higher output levels and functionality, efforts that I'm sure will only improve the reputation of Sony's single-stripe laser diode technology.

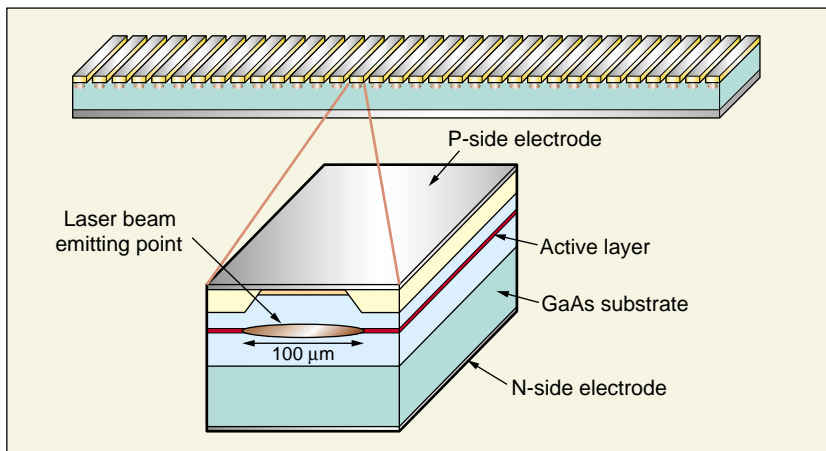

■ Figure 1 SLD433S4 Chip Structure

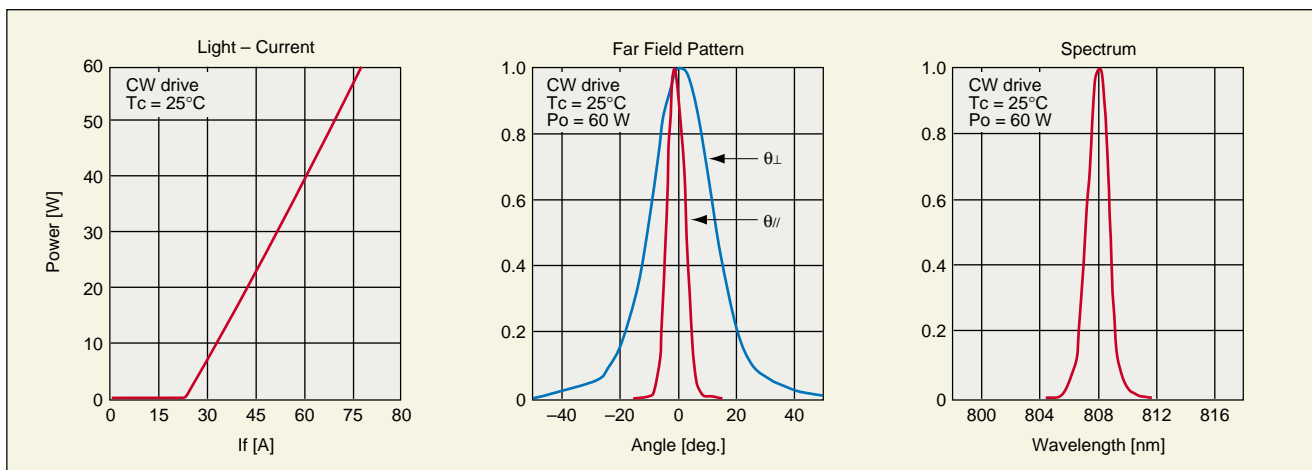

■ Figure 2 SLD433S4 Representative Characteristics

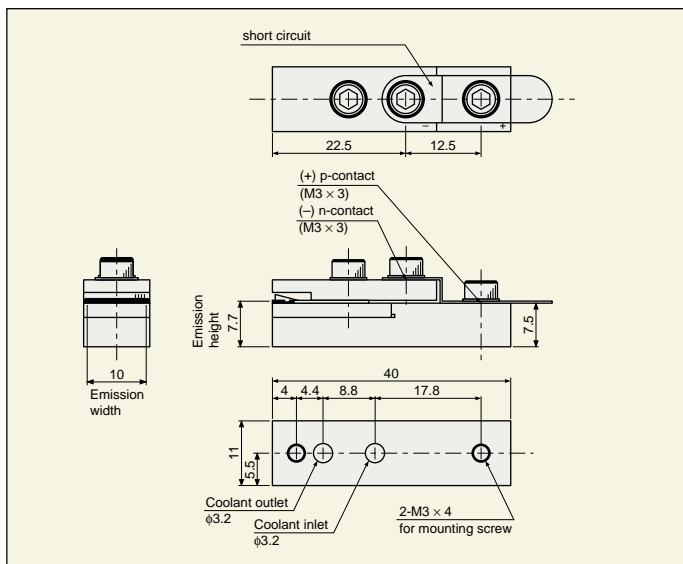

■ Figure 3 SLD433S4 Package Dimensions

■ Table 1 SLD433S4 Main Specifications

Item	Symbol	Typ.	Unit
Threshold current	$I_{th}$	24	A
Operating current	$I_{op}$	78	
Operating voltage	$V_{op}$	1.9	V
Wavelength	$\lambda_p$	808	nm
Radiation angle	Parallel	$\theta_{//}$	deg.
	Perpendicular	$\theta_{\perp}$	
Differential efficiency	$\eta_D$	1.1	W/A

Condition:  $T_c = 25^\circ\text{C}$   
 $P_o = 60\text{ W@CW}$