

Ultraminiature Two-Wavelength Integrated Laser Coupler Devices for Car DVD and CD Players

SLK3202RE

To respond to the requirements of car DVD players, car navigation systems, and car CD changers, Sony has now developed the SLK3202RE integrated optical device (laser coupler) that is the core component in the DVD/CD player pickup.

By adopting the industry's first pulsation laser that guarantees operation at 85°C to obviate the need for high-frequency superposition and incorporating circularly polarized emitting technology, this device can simplify the optical pickup used for DVD and CD playback.

- Monolithic two-wavelength laser operates at 85°C and does not require high-frequency superposition
- Supports ultraminiature thin form factor two-wavelength pickups
- Uses the same servo technique as existing pickups
- Supports 8× speed for both DVD and CD
- Circularly polarized emitting for high playability

■ Monolithic Two-Wavelength Laser Operates at 85°C

This device includes the industry's first pulsation laser that guarantees operation at 85°C. Furthermore, no high-frequency module is required, obviating the need for spurious radiation prevention measures. This device achieves low noise over a wide operating temperature range and high reliability.

■ Supports Miniature Thin Form Factor Two-Wavelength Pickups

The SLK3202RE features the ultraminiature size of 7.6 × 3.7 × 6.35 mm, and can easily be mounted in thin form pickups.

■ Circularly Polarized Emitting for High Playability

The SLK3202RE provides a circularly polarized beam by using a low cost built-in 1/4 wavelength plate. Using an unpolarized optical system for the internal optical system makes the SLK3202RE immune to variations in disc refraction and other problems and allows optical pickups with high playability to be implemented. At the same time, this increases stability with respect to returning light even further.

■ Supports 8× Speed for both DVD and CD

The SLK3202RE supports 8× speed for both DVD and CD by achieving a 110 MHz bandwidth on the DVD side and a 40 MHz bandwidth on the CD side. Furthermore, it responds to needs to support both single and two-layer DVD discs, and both normal and low-reflective CD discs by providing an internal two-level gain switching function in the PDIC.

■ Miniature 18-Pin Ceramic Package

The SLK3202RE adopts the same size miniature thin form factor ceramic package used in Sony's MD laser couplers, devices with a proven track record. This allows it to support further miniaturization and lower costs in end products.

V O I C E

Laser couplers are integrated optical devices implemented using ultrahigh precision semiconductor mounting technologies. By modularization, miniaturization, and integration of the required structural components in the optical pickup, Sony was able to simplify the structural components in the pickup. We achieved even further miniaturization in the SLK3202RE, under the assumption that it will be used in a wide range of car DVD and CD products. I hope that many of our customers will be able to take advantage of this impressive product.

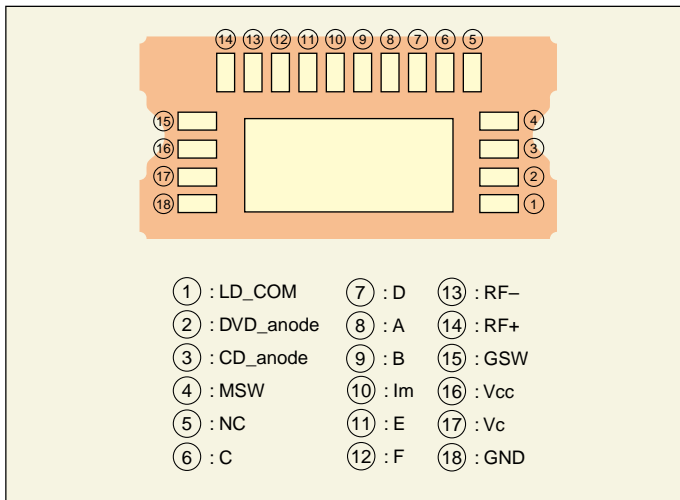

■ Figure 1 Pin Configuration

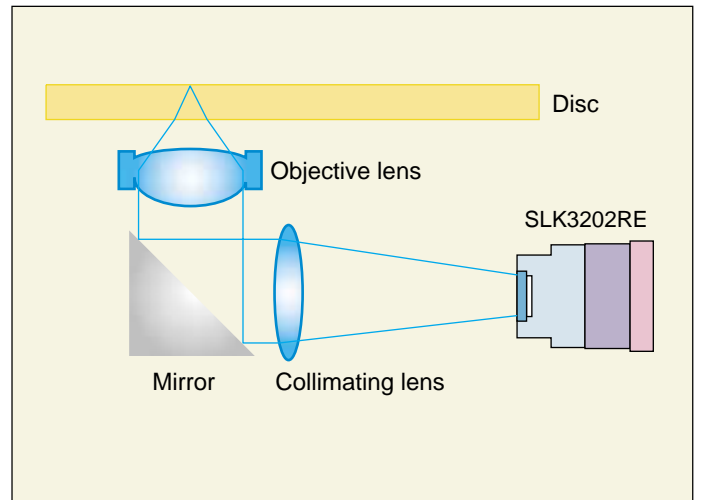

■ Figure 2 Optical Pickup Structural Example (6× system)

■ Table 1 Main Characteristics

<DVD Side>

Tc = 25°C

	Item	Symbol	Typ.	Unit	Notes
Laser characteristics	Operating power (LC emitting)	Po_a	2.2	mW	The typical emission corresponds to the original LD emission at 3.7 mW
	Operating current	lop1_a	50	mA	LC emission: 2.2 mW
	Operating voltage	Vop_a	2.3	V	LC emission: 2.2 mW
	Wavelength	λ_a	668	nm	LC emission: 2.2 mW
	Astigmatic difference	AS_a	20	μm	LC emission: 2.2 mW
PDIC characteristics	Current consumption	Icc_a	16	mA	LD off, with light blocked
	Frequency response (low gain mode)	fA, fB, fC, fD	90	MHz	-3 dB referenced to 100 kHz
		fRF+, fRF-	97	MHz	-3 dB referenced to 100 kHz
	Frequency response (high gain mode)	fA, fB, fC, fD	60	MHz	-3 dB referenced to 100 kHz
		fRF+, fRF-	68	MHz	-3 dB referenced to 100 kHz
	Supply voltage	Vcc	5	V	Referenced to GND
	Reference voltage	Vc	2.5	V	Referenced to GND
	Group delay	$\Delta\text{GdRF+}, \Delta\text{GdRF+}$	—	ns	Group delay from 100 kHz to 36 MHz
Gain switching ratio	Rg_a	1.7		High gain mode/low gain mode	

<CD Side>

Tc = 25°C (Except for lop2_b)

	Item	Symbol	Typ.	Unit	Notes
Laser characteristics	Operating power (LC emitting)	Po_b	2	mW	The typical emission corresponds to the original LD emission at 3.5 mW
	Operating current	lop1_b	65	mA	LC emission: 2.0 mW
	Operating voltage	Vop_b	1.8	V	LC emission: 2.0 mW
	Wavelength	λ_b	785	nm	LC emission: 2.0 mW
	Astigmatic difference	AS_b	30	μm	LC emission: 2.0 mW
PDIC characteristics	Current consumption	Icc_a	16	mA	LD off, with light blocked
	Frequency response (low gain mode)	fa, fb, fc, fd	14	MHz	-3 dB referenced to 100 kHz
		fe, ff	—	MHz	-3 dB referenced to 100 kHz
		frf+, frf-	14	MHz	-3 dB referenced to 100 kHz
	Frequency response (high gain mode)	fa, fb, fc, fd	11	MHz	-3 dB referenced to 100 kHz
		fe, ff	—	MHz	-3 dB referenced to 100 kHz
		frf+, frf-	11	MHz	-3 dB referenced to 100 kHz
	Supply voltage	Vcc	5	V	Referenced to GND
	Reference voltage	Vc	2.5	V	Referenced to GND
Group delay	$\Delta\text{GdRF+}, \Delta\text{GdRF+}$	—	ns	Group delay from 100 kHz to 36 MHz	
Gain switching ratio	Rg_b	1.7		High gain mode/low gain mode	