

FEATURING

Optical Disc Record System Semiconductor Laser Diode Lineup 250 mW Semiconductor Laser Diodes that Contribute to Faster Data Write Operations in CD-R/RW and 100 mW Semiconductor Laser Diodes for DVD+R/RW and DVD-R/RW

- Full lineup of CD/DVD recording system semiconductor laser diodes
- High power output & low power consumption
- Sony devices provide the highest recording speeds
- General-purpose $\phi 5.6$ packages and 3.0 mm thickness ultrathin packages for ultraslim drives

The needs for optical storage that can quickly store large amounts of content data and that can be searched easily are increasing due to the widespread use of high-speed personal computers and the availability of broadband networks. Both CD-R/RW and DVD+R/RW or DVD-R/RW drives are now indispensable as external mass storage for personal computers. Thus there are increasing demands for improved characteristics in laser diodes, which are one of the main component technologies for increasing the data write speeds of optical media.

It is usually said that doubling the record speed requires increasing the laser diode optical power output by a factor of $\sqrt{2}$. Since increasing the record speed means changing the physical characteristics of the recording medium in an even shorter time, high energies are required. Thus we can say that increasing the optical power output of laser diodes is a key technology that is directly linked to the recording speed of optical disc drives.

The new requirement for the achievement of 9.5 mm optical disc drives, which would have the same thickness as slim hard disk drives, has been added to the specifications for the latest notebook personal computers. In the process of reducing the thickness of optical disc drives,

which are a type of removable media, the allowable thickness for the optical pickup has become even smaller. Thus it has become necessary to apply thin form factor design to the laser diode package as well to achieve this goal.

Sony is now releasing the SLD253VL and SLD1233VL in the context of these increasingly diverse market needs. The SLD253VL, which supports the fastest data write speeds to CD-R/RW media, achieves the highest performance (250 mW) of any 780 nm band high power semiconductor laser diode. Furthermore, Sony now provides a product lineup that spans from 180 mW lasers for $\times 32$ -speed recording to 250 mW lasers that make $\times 52$ -speed recording possible.

At the same time, Sony is also releasing the SLD1233VL 650 nm band high power semiconductor laser diode that makes $\times 4$ -speed recording possible for DVD-R/RW and DVD+R/RW drives. Sony is taking the lead in creating a supply system for the DVD recording marketplace, which is expected to see strong growth in the near future.

Sony has developed a new 3.0 mm thick ultrathin package for the laser diodes used in 9.5 mm thick optical disc drives. Since the thin form factor drive market is also shifting towards drives that support high

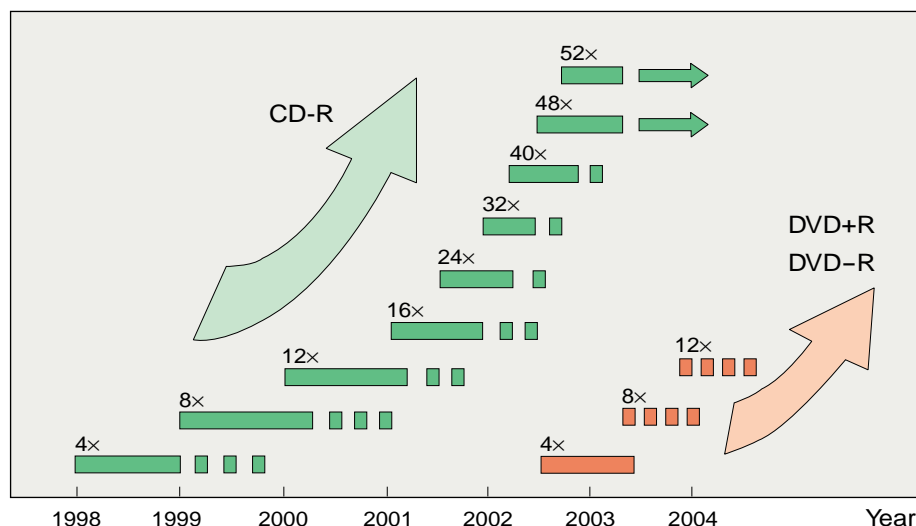

■ Figure 1 Developments in CD-R and DVD+R/DVD-R Recording Speeds

recording speeds, this package features a thermal design equivalent to that of the $\phi 5.6$ mm standard package. Sony is committed to continuing to release new products that include laser diodes for CD-R/RW, DVD-R/RW, and DVD+R/RW drives.

SLD253VL 250 mW Laser Diode for CD-R/RW Drives

In creating the SLD253VL semiconductor laser diode for use in CD-R/RW drives, Sony achieved the high pulse output rating of 250 mW by adopting both an emitting surface protective coating technology that prevents COD (catastrophical optical damage: optical damage due to the device's own optical power output) and is based on MOCVD (metal organic chemical vapor deposition),

which is a unique Sony technology for semiconductor crystal growth, as well as a waveguide structure that suppresses laser beam transmission loss within the laser diode itself.

This new device significantly surpasses the performance of current 220 mW output semiconductor laser diode products, which themselves have a proven track record in $\times 48$ -speed CD-R recording, and is a semiconductor that can support $\times 48$ -speed and higher speed CD-R recording, even in CD-R/DVD combo drives, in which it is difficult to assure high laser beam utilization efficiency. Another feature of this product is its low-impedance design, which makes short pulse operation easier without applying excessive load on the drive circuit. Table 1 lists the characteristics of this device at room temperature (P_o : 100 mW CW).

In CD-R optical system design, degrees of freedom in the high-frequency modulation conditions can be assured, and the problem of undesired radiation reduced, by avoiding the laser diode interference distance in the design. However, it is often difficult to avoid the interference distance in actual designs. For optical pickups that have an optical path length that is an integer multiple of the interference distance when the SLD252VL or SLD253VL (interference distance: 3.57 mm) is used, Sony also provides the SLD251VL, which features an interference distance of 3.41 mm.

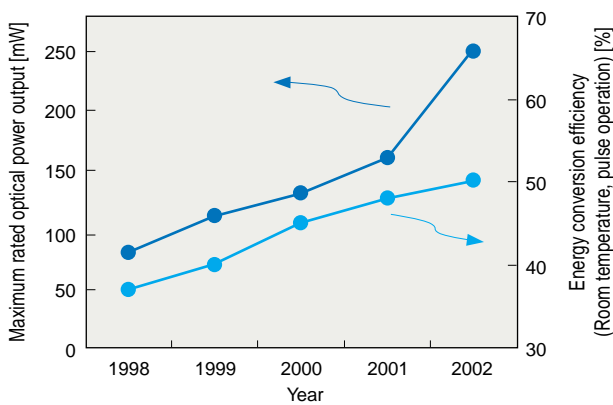

■ Figure 2 Trends in CD-R Laser Diode Optical Power Output and Conversion Efficiency

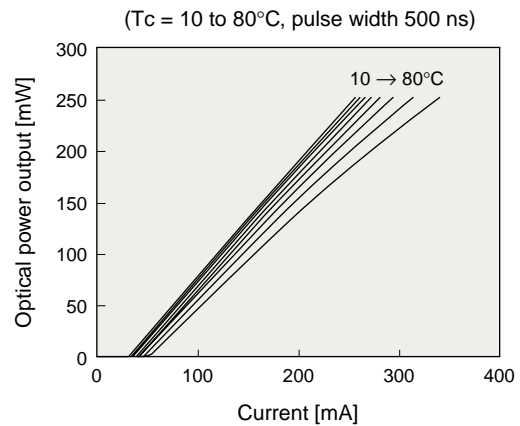

■ Figure 3 Temperature Dependency of SLD253VL Optical Power Output vs. Current Characteristics

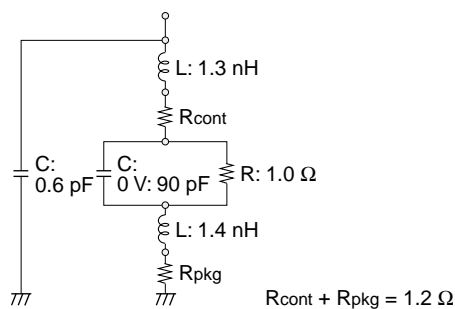

■ Figure 4 SLD253VL Equivalent Circuit

■ Table 1 SLD253VL Room Temperature Characteristics (P_o : 100 mW CW)

Item	Symbol	Typical value	Unit
Operating current	I_{op}	130	mA
Operating voltage	V_{op}	2.0	V
Wavelength	λ_p	784	nm
Radiation angle	Parallel	$\theta_{//}$	deg.
	Perpendicular	θ_{\perp}	

Power consumption at 70°C, 250 mW: 0.63 W (300 mA, 2.1 V)
Wavelength temperature dependency: 0.25 nm/°C
Interference distance nL (n = refractive index, L = cavity length): 3.57 mm

SLD1233VL Laser Diode for DVD-R/RW and DVD+R/RW Drives

In the SLD1233VL laser diode for DVD-R/RW and DVD+R/RW drives, Sony adopted a window structure that does not absorb the laser beam at the laser beam emitting point and an actual refractive index waveguide structure that suppresses transmission loss of the laser beam within the laser diode itself. As a result, this device achieves a 100 mW pulse output, which can support $\times 4$ -speed DVD recording. While AlGaInP, which is a four-element semiconductor crystal, is used in

DVD laser diodes, large fluctuations in the refractive index have been measured due to the self-heating nature of the material.

To minimize the influence of this phenomenon, Sony achieved a horizontal emission angle fluctuation of less than 1.0 degree in both recording and playback operation. Table 2 lists the characteristics of this device at room temperature (P_o : 50 mW CW).

The competition in DVD recording speed is expected to heat up even further. Sony is committed to working towards the development of laser diodes for $\times 8$, $\times 12$, and even $\times 16$ -speed recording and to delivering products that respond to market needs.

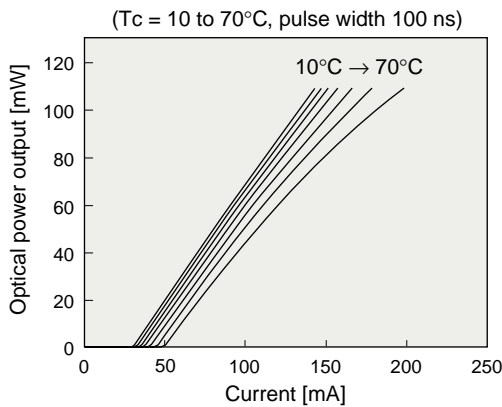

■ Figure 5 Temperature Dependency of SLD1233VL Optical Power Output vs. Current Characteristics

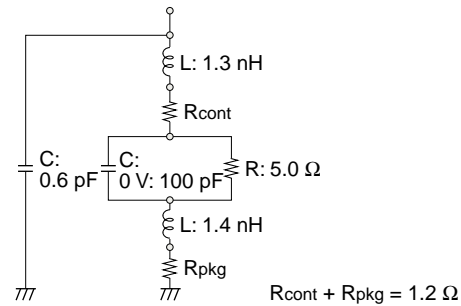

■ Figure 6 SLD1233VL Equivalent Circuit

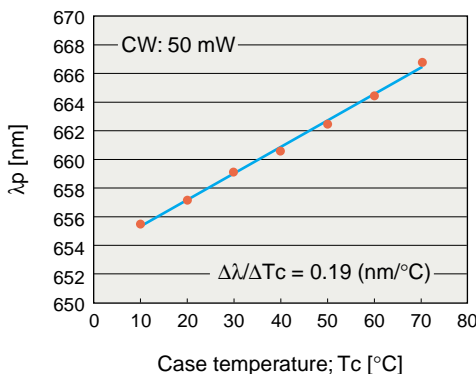

■ Figure 7 Temperature Dependency of SLD1233VL Wavelength

■ Table 2 SLD1233VL Room Temperature Characteristics (P_o : 50 mW CW)

Item	Symbol	Typical value	Unit
Operating current	I_{op}	85	mA
Operating voltage	V_{op}	2.5	V
Wavelength	λ_p	658	nm
Radiation angle	Parallel	$\theta_{//}$	deg.
	Perpendicular	θ_{\perp}	

Power consumption at 70°C , 100 mW: 0.54 W (200 mA, 2.7 V)
 Wavelength temperature dependency: 0.19 nm/ $^\circ\text{C}$
 Interference distance nL (n = refractive index, L = cavity length): 3.68 mm

Ultrathin High Heat Dissipation Package for Thinner Optical Disc Drives

While notebook personal computers that include optical disc drives have become the mainstream in the current market, the thickness of the optical disc drives is seen as one component that limits further progress in creating even thinner notebook personal computers. Although the standard thickness of thin form optical disc drives for notebook personal computers is now 12.7 mm, there are growing needs for even thinner drives in mobile applications, an area where thinner products are strongly desired. The standard which is now being moved forward towards commercialization as the next target for slim drive is the same thickness as that of thin-form hard disk drives, that is, drives with a thickness of 9.5 mm. To differentiate 9.5 mm optical disc drives from conventional slim drives, these new drives will be called "ultraslim drives." Achieving this drive thickness in the removable disc world where the media thickness is 1.2 mm will require high-level technologies.

Sony is proposing solutions for this field by developing a new ultrathin package with a thickness of 3.0 mm. This package is designed to lose none of the thermal dissipation characteristics of the $\phi 5.6$ mm package, which is a standard product, and since it is a fully sealed package, it can be used with confidence in its reliability. It supports the fastest speeds used in slim system drives and is also designed to package semiconductor laser diodes for DVD-R/RW and DVD+R/RW drives.

Future Developments

Sony is committed to continued research and development on laser diodes, which are a key device for optical disc drives, and to continue to support our users by responding to diverse market needs, including needs for higher speeds, larger capacities, further miniaturization, and lower power consumption in optical storage recording systems.

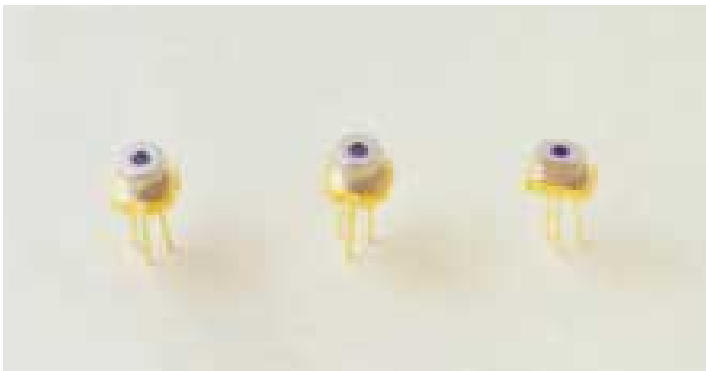

■ Photograph 1 SLD253VL (left) and SLD1233VL (center) $\phi 5.6$ mm Package and 3.0 mm Ultrathin Package (right)