

# CXA2636N, CXA2637N, CXA2632EM

The competition to provide even higher speeds in optical disc drives is becoming increasingly fierce. Recently, the arena for this competition has shifted from playback performance to write performance, and write speeds are fast catching up with read speeds.

Now, Sony has developed a photodetector IC (PDIC) that supports 32×-speed write. This device takes full advantage of the P-42B process, which has a two and one half year volume production track record, as an ultrahigh-speed photodiode IC fabrication process.

Sony has perfected a product that has characteristics at the top level in the industry and aims at deployment in DVD recording.

Sony has also developed a new laser front monitor, and has achieved a full product line of photodetector devices for optical disc recording systems.

- Supports 32×-speed write CD-R
- Includes a gain switching function (9 dB)
- Low noise (−88 dBm during playback for the A to D signals)
- Built-in RF output (sum of the A to D signals)
- Miniature transparent 14-pin surface mounting type (gull wing) molded package

## CXA2636N/CXA2637N

The CXA2636N and CXA2637N are the photodetector ICs (PDIC) that detect light reflected from the disc. The CXA2636N and CXA2637N only differ in the size of the photoreceptor area, and have patterns that expect the corresponding limited and unlimited optical systems.

### ■ Response Speed

To achieve 32×-speed write, Sony has increased the pulse response speed as shown in table 1.

### ■ Gain Switching Function

These devices include a 9 dB gain switching function to allow them to both avoid output saturation when a high-power laser is used and to assure an adequate signal-to-noise ratio during playback.

### ■ Low Noise

These devices retain the low noise which is a feature of Sony PDIC products by forming the I-V amplifier (current to voltage conversion circuit) as a single stage and by adopting a technique in which the transimpedance is switched by switching the gain. Also, since these ICs provide an RF output (the summed output of the A to D main beam signals), they make it possible to reproduce the faint signals from CD-RW and other formats clearly.

### ■ Miniature Transparent Molded Package

Since these devices retain the body size of the conventional 12-pin package while providing 14 pins, they allow the size of the optical pickup to be maintained. Furthermore, these devices take mounting simplification into consideration by adopting a surface mounting type (the so-called “gull wing” form) for the lead geometry. Note that this package can withstand reflow soldering, although certain conditions do apply.

## CXA2632EM

The CXA2632EM is a laser diode power monitor (front monitor) PDIC.

### ■ COB Package

The CXA2632EM adopts a newly-developed ultraminiature COB (chip on board) package, and since it includes a built-in power supply decoupling capacitors, it can contribute to reducing the mounting area. This package also supports reflow soldering.

### ■ Response Speed

Since this device has a response time of 20 ns (maximum), it is more than adequate for 32×-speed write drives.

### ■ Wide Dynamic Range

This device achieves an output dynamic range of 2.8 V (typical) when  $V_{ref}$  is 3.0 V due to a new circuit type.

## V O I C E

Recently, I have been very busy, designing several custom ICs every month to respond to specific customer needs. Not only does this involve designing all the circuits, but it even extends to taking detailed care over individual transistor and other device layout. I am confident that this level of care means that these ICs will fully satisfy our customers' needs. Since I will be developing high-performance products, I strongly recommend that you try these ICs in your products.



*New  
Products*

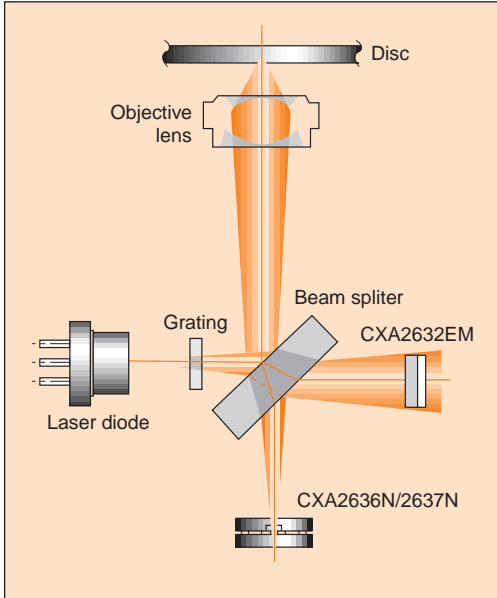

■ Figure 1 Optical Pickup Structure

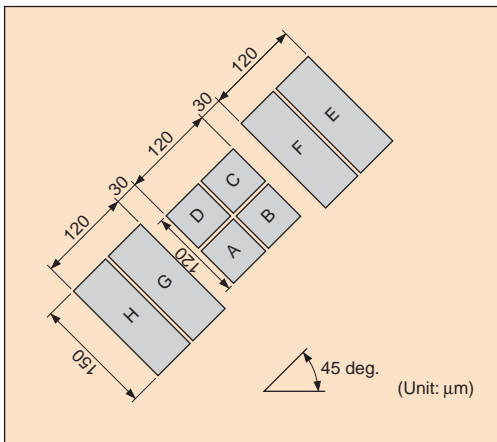

■ Figure 3-1 CXA2636N Photodetector Pattern Dimensions

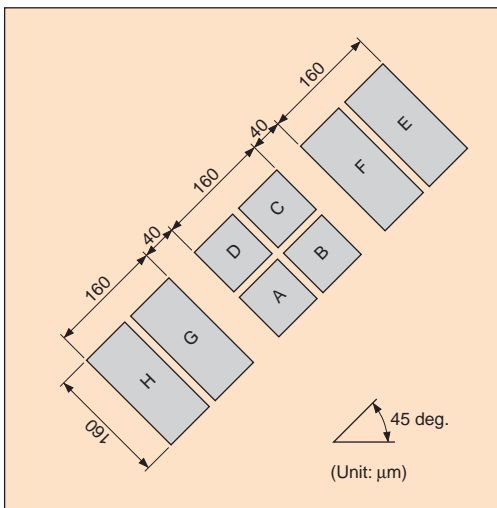

■ Figure 3-2 CXA2637N Photodetector Pattern Dimensions

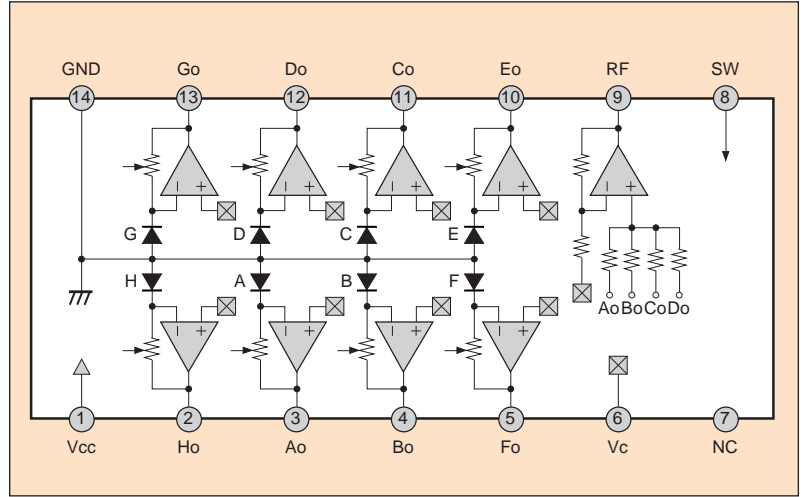

■ Figure 2 CXA2636N/CXA2637N Block Diagram

■ Table 1 Pulse Response Speed

|             |               |                 |
|-------------|---------------|-----------------|
| Main signal | Slew rate     | 350 V/μs (Typ.) |
|             | Settling time | 10 ns (Typ.)    |
| Sub-signal  | Slew rate     | 150 V/μs (Typ.) |
|             | Settling time | 15 ns (Typ.)    |

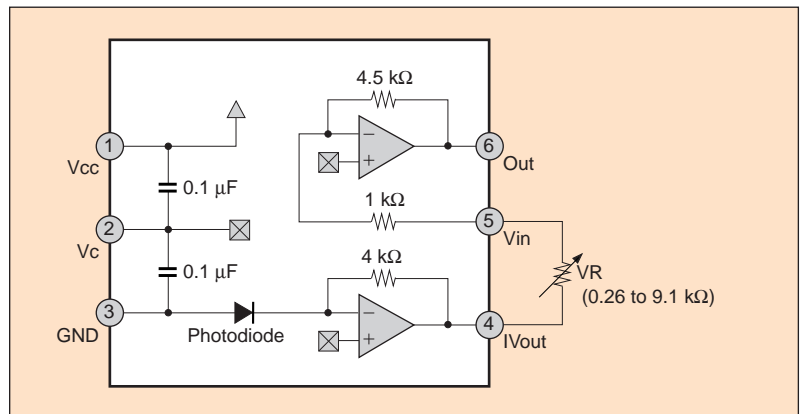

■ Figure 4 CXA2632EM Block Diagram

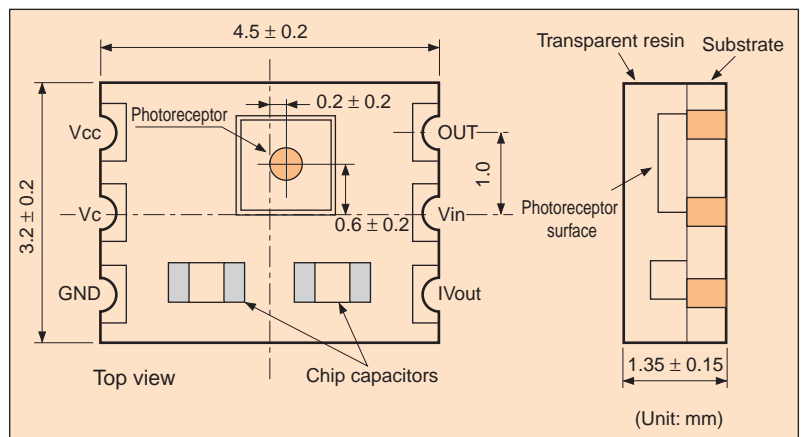

■ Figure 5 CXA2632EM Package Dimensions