

Mixed-signal process achieves both medium-voltage handling and higher speeds

Introducing the P52H 0.6 μm CBiCMOS Process Technology

- Reduced feature size process for medium-voltage driver ICs
- Allows complementary bipolar transistors to be fabricated
- Analog/digital hybrid circuits using CMOS transistors
- Medium-voltage MOS transistors can be included
- Device solutions based on an extensive set of device types

With the rapid advances now being made in the broadband area, semiconductor manufacturers are increasing the speed and voltage handling capabilities of their mixed-signal ICs, and these devices are now used in a wide range of products. Of these devices, although medium-voltage high-speed driver ICs in particular are expected to exhibit strong growth, the currently used devices can not be said to be optimal. One example would be the hard disk read/write IC. (See figure 1.) Hard disk capacities are increasing every year, and the data transfer rates are increasing along with the capacity. Since higher data rates can be achieved with proportionally higher supply voltages, it is becoming harder to use devices limited to handling only low voltages at these high speeds.

Another example is the display driver ICs used to drive LCDs and other display devices. (See figure 2.) A supply voltage of approximately 8 V (or higher) is required to drive these display elements, and high speed is also required.

Creating devices that achieve high frequencies (higher speeds) and high integration densities (smaller feature sizes) reduces the operating voltage. Thus it is commonly thought that it is difficult to achieve higher speeds and smaller feature sizes in devices that can handle high voltages.

Sony has now developed the P52H CBiCMOS* process that provides optimal device solutions for driver applications that require both 8 V and higher medium-voltage power supplies as well as higher speeds.

* CBiCMOS: Complementary Bipolar Complementary MOS

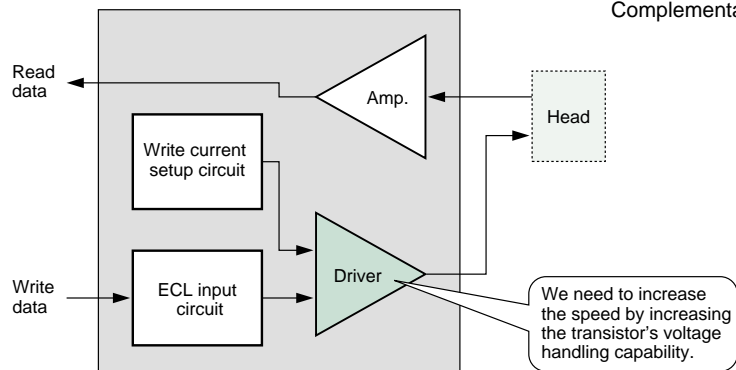

■ Figure 1 Hard Disk Read/Write IC Structure

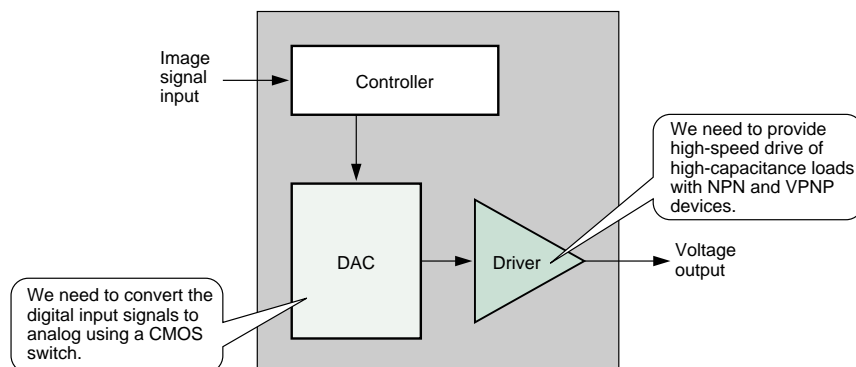

■ Figure 2 LCD Driver IC Structure

Smaller Features Size Process for Medium-Voltage Driver ICs

The main target of the P52H process is the class of driver that requires higher speeds and medium-voltage levels. In general, the characteristics (in particular, speed) of devices currently used in medium-voltage drivers are not particularly advanced. This is because the frequency response and the voltage handling capability of these transistors are in a tradeoff relationship.

The P52H process is based on Sony's leading-edge smaller feature size P52 process, which is a BiCMOS process that allows both high-frequency bipolar transistors and CMOS transistors to be fabricated on the same chip. However, in the P52H process, Sony succeeded in increasing the voltage handling capability of the devices on the chip. (See figure 3.) This allows this process to cover the medium-voltage high-speed region of device performance.

The assets developed for the P52 process, the basis for the P52H process, can be used without modification. That it is possible to include devices from the whole range of mixed-signal process technologies, including 5 V CMOS transistors and bipolar transistors with the top performance in the industry. Medium-voltage MOS transistors without additional processing can be used as well. This makes the P52H an extremely high added value process.

Complementary High-Speed Bipolar Transistor Achieved

The bipolar transistors fabricated in P52H process ICs inherit the same design rules (0.6 μm) used in the P52 process, and thus this process supports IC miniaturization. Furthermore, by the adoption of emitter/base formation technology using self alignment and the optimization of the collector impurity profile, Sony has achieved the industry's top performance level in the supply voltage \times f_{rmax} product. (See figure 4.)

Sony has also added a new vertical PNP transistor to achieve a complementary device. Although processes that can fabricate V-PNP transistors are usually quite complex, Sony has made it possible to fabricate V-PNP transistors by aiming for joint use of these processes.

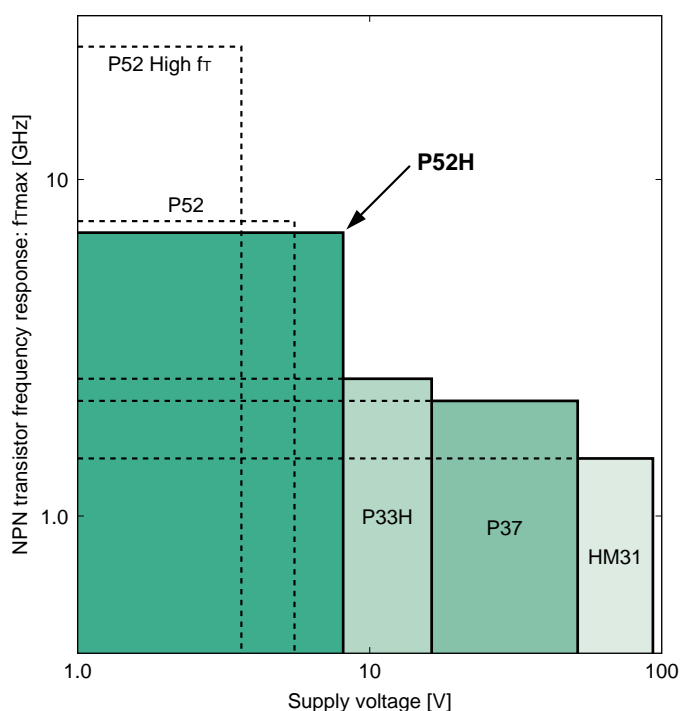

■ Figure 3 Sony Driver IC Process Lineup

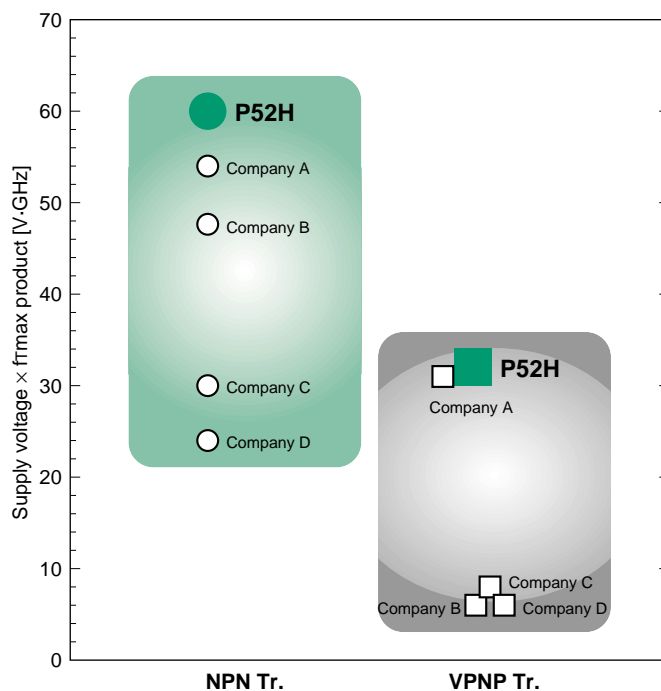

■ Figure 4 CBiCMOS Process Bipolar Transistor Performance Comparison

Device Solutions Built from an Extensive Set of Basic Devices

In addition to three standard device types, npn transistors, lateral pnp transistors, and polycrystalline silicon resistors, the P52H process also supports a rich set of optional devices not available from other semiconductor manufacturers. These include high-frequency (f_{rmax} : 20 GHz) npn transistors, high current amplification (β : 600) npn transistors, high-performance vertical pnp transistors, 5 V CMOS transistors, medium-voltage MOS transistors, high-capacitance MIS capacitors, and trimmable elements (Zener zap diodes). (See table 1.)

Since the P52H can integrate all these devices on a single chip, not only is it appropriate for driver ICs, but it can also flexibly support ICs that require a wide variety of functions and performance specifications.

Future Developments

Sony is committed to full support of the medium-voltage product category, an area which requires both high speed and voltage handling capability. To provide that support, Sony will continue to strive for further feature size reductions and improved performance in CMOS transistors, and improved performance in bipolar transistors. In particular, Sony will continue to develop mixed-signal process technologies that can provide, in a timely manner, devices that meet our customers needs. Keep your eye on Sony's mixed-signal process technologies that support the broadband age.

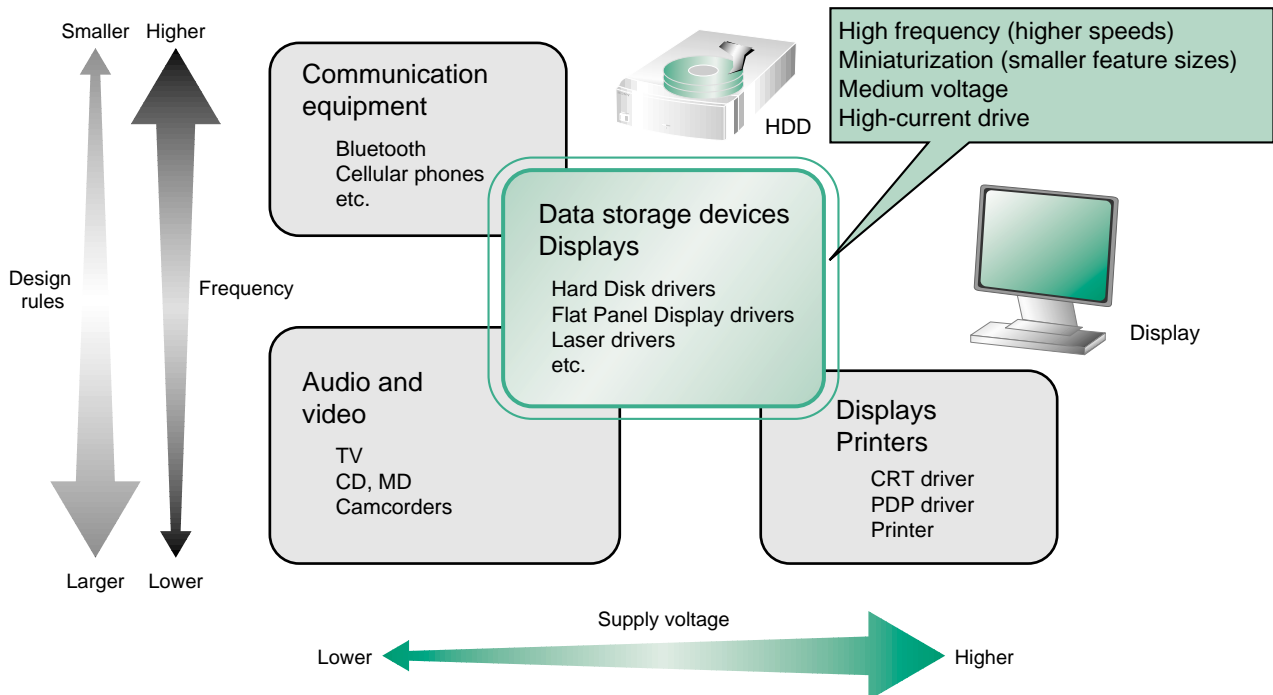

■ Figure 6 Sony Mixed-Signal Product Categories