

SVCD/VCD/CD/MP3 Decoder IC
Integrates CD-DSP, MPEG2, and Video Decoder Functions

CXD1888R

The newly-developed CXD1888R is an eagerly awaited SoC(System-on-Chip) device that is the industry's first SVCD player IC implementation.

The CXD1888R integrates a CD-DSP, an MPEG decoder, and a video encoder on a single chip to reduce the number of required components and to reduce the size of the PWB.

Since this chip can be switched between NTSC and PAL operation, multiple models can be designed using a single PWB.

Furthermore, this IC also adds MP3 functions in response to market needs, and a system consisting of just the CXD1888R can support SVCD (super VCD), VCD, CD, and MP3 discs and can implement functions from normal playback through special playback.

- NTSC and PAL support
- Built-in 32-bit DSP
- Built-in 32-bit RISC processor
- Powerful error correction
- 216-pin LQFP package

■ What is SVCD?

SVCD is a modification to VCD that doubles the playback speed to allow MPEG2 to be handled. It is a standard that is mainly used in China.

■ CD-DSP

This digital signal processor features an internal VCO, support for playback speeds from normal to 4×-speed, powerful error correction that provides dual C1 and quad C2 correction. This CD-DSP's digital servo functions are controlled in software by the internal RISC CPU.

■ MPEG Decoder Block

The CXD1888R supports MP3 and other audio compression algorithms using its built-in 32-bit DSP. It also supports later algorithm extensions and can flexibly support new features.

Since the CXD1888R performs high-speed arithmetic processing in hardware, it provides real-time processing and cost effectiveness. It can also support game emulation, karaoke applications, graphic equalizers, and digital recording (audio can be recorded and then played back along with disc playback).

■ Video Encoder

The video encoder function supports worldwide markets by supporting both NTSC and PAL.

■ Striving for Ease-of-Use

The CXD1888R can implement an SVCD/VCD/CD/MP3 player with the addition of only memory and analog components, and implements internally all functions and processing required for normal playback to special playback with its built-in MPEG decoder, advanced video processor and NTSC/PAL encoder. It includes two audio output systems (L0, R0, L1, and R1) that can be operated independently.

V O I C E

This system was created with the cooperation and efforts of many people, including system engineers, hardware engineers, and PWB engineers. Furthermore, it was a truly international team that included both American and Chinese members, and there were quite a few difficulties on the road to completion of the project. I hope that you will try using this product as a total system, including the PWB and software we developed.



New Products

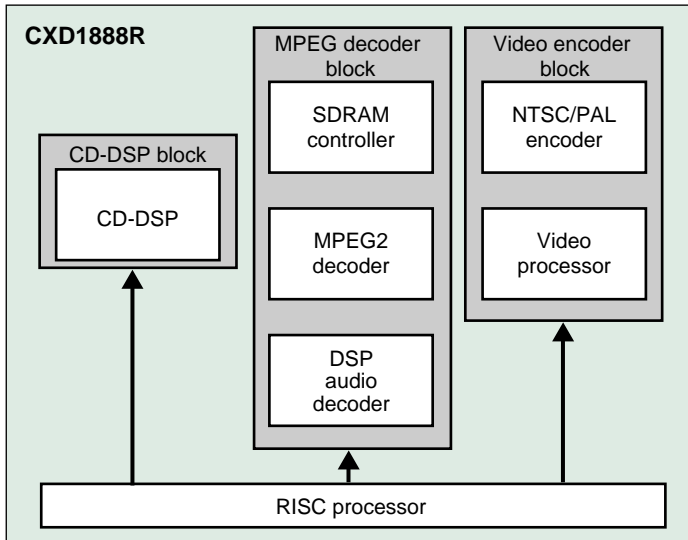

■ Figure 1 CXD1888R Block Diagram

■ Table 1 Recommended Operating Conditions

Supply voltage	AV _{DD}	2.3 to 2.7 V
	V _{DD1}	2.3 to 2.7 V
	V _{DD2}	3.0 to 3.6 V
Operating temperature	T _{opr}	-20 to +70°C
Operating frequency		54 MHz

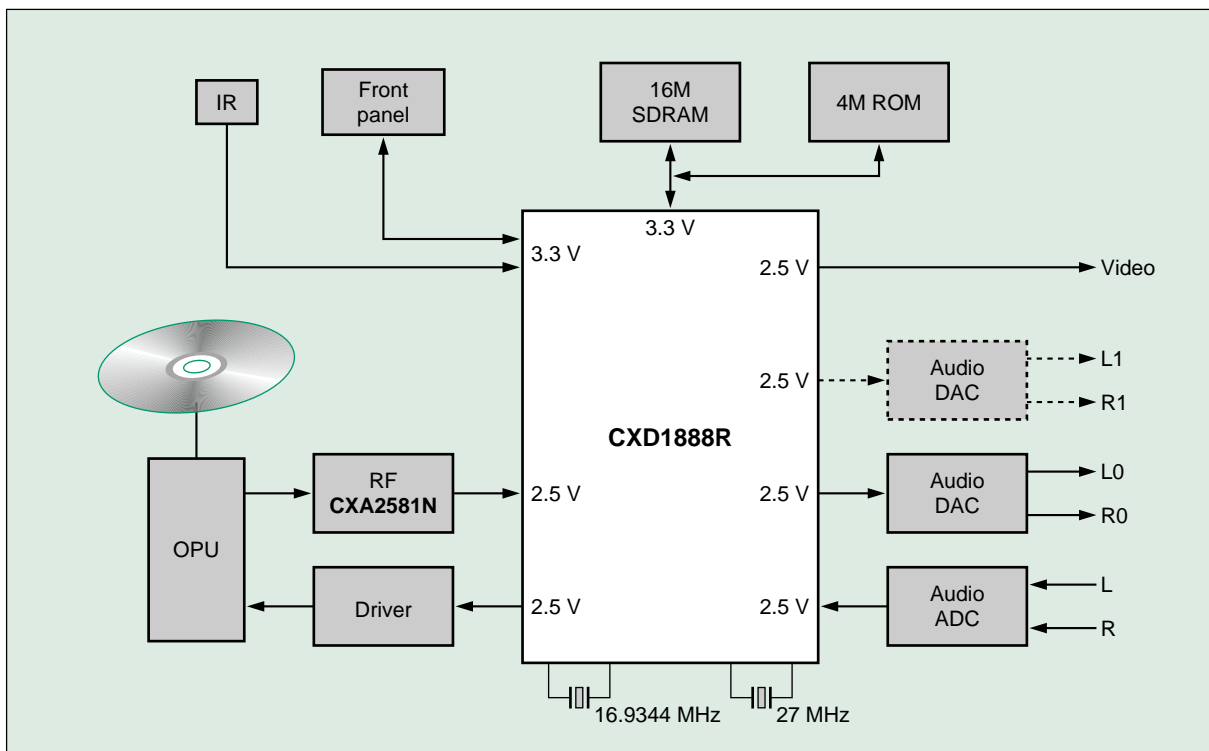

■ Figure 2 CXD1888R Application Circuit