

Ultraminiature High-Precision

1.1cm (0.44-Type) 113K/180K-pixel EVF Color and Black-and-White LCDs

LCX032AK, LCX032AL LCX033AK, LCX033AL

Camcorders get smaller and smaller every year, and digital still cameras are becoming increasingly popular.

This means that further miniaturization and higher performance are now strongly desired in the LCDs used as the viewfinders in these products.

Furthermore, there is now a demand for black-and-white EVFs. The LCX032AK/AL and the LCX033AK/AL are the favorites to be the LCDs for the next generation of EVFs that must be developed to respond to these market needs.

- 1.1 cm (0.44-Type)
113K or 180K pixels
- High transmittance
LCX032AK: 4.8%
LCX033AK: 4.0%
LCX032AL: 14.4%
LCX033AL: 12.0 %
- Up/down and/or right/left inversion functions
- Support for both 4:3 and 16:9 display
- Low power modes

■ The Best Choice for the Next Generation of EVFs

The Sony line of 1.4 cm (0.55-Type) EVF LCD products has been well received by the camcorder market. Now, to contribute to even further to end product miniaturization and lower power consumption, we have developed the LCX032/033 series of 1.1 cm (0.44-Type) EVF LCDs. In developing these new products we reconsidered the design rules used and introduced on-chip color filters. Furthermore, we developed new color filter materials and achieved transmittances of 4.8% (LCX032AK) and 4.0% (LCX033AK), levels equal to or higher than those of previous products. Thus these products provide high performance despite miniaturization. (See table 1.)

■ Extensive Set of Built-in Functions

In addition to the right/left inversion function provided by earlier models, the LCX032/033 series also provides an up/down inversion function for an added degree of freedom in end product design. And it goes without saying that they provide an aspect ratio switching function between the 4:3 and 16:9 aspect ratios for wide-screen TV. Furthermore, to support lower power consumption in camcorders, a standby mode has been added. This allows power consumption in standby mode to be held to under 1 mW. (See figure 1.)

■ Black-and-White Models also Included in the Product Line

In addition to the color display AK type, the LCX032/033 series also includes black-and-white display AL type. These allow end products that previously used CRTs to use LCDs for further miniaturization. Since these black-and-white panels have no color filters, they achieve the high transmittance of 14.4% (LCX032AL) and 12.0% (LCX033AL). (See table 1.)

■ System IC

At the same time as developing the LCX032/033 series, Sony also developed the CXA3503R special-purpose timing generator/driver IC. This IC integrates a timing generator and an RGB driver on a single chip, and supports both NTSC and PAL. This IC accepts both Y/color difference and RGB inputs. To support the features of these panels, the CXA3503R includes up/down and/or right/left inversion functions, a wide-screen display function, and standby mode. All of these functions can be controlled using serially transmitted data. (See figures 2 and 3.)

V O I C E

We aimed to create the standard for the next generation of EVFs when we developed the LCX032AK/AL and the LCX033AK/AL. It was quite a challenge to achieve high transmittance in such a small device. I expect to see even smaller products with designs that are even more flexible.

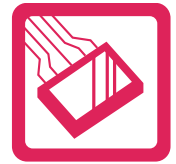

New Products

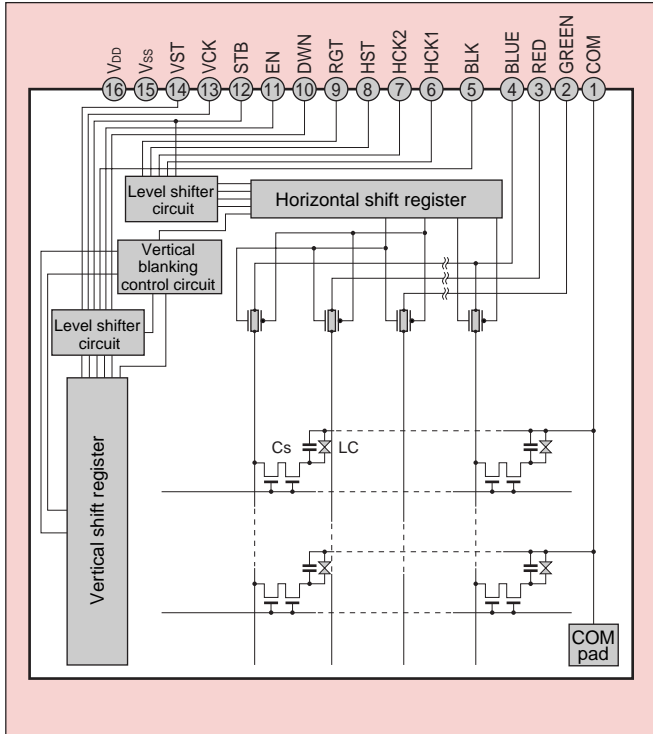

■ Figure 1 LCX032AK/AL and LCX033AK/AL Block Diagram

■ Table 1 Panel Specification

	LCX032AK	LCX033AK	LCX032AL	LCX033AL
Display type	Color	Color	Black and white	Black and white
Number of pixels	113K	180K	113K	180K
Aperture ratio	45%	38.3%	45%	38.3%
Optical transmittance	4.8%	4.0%	14.4%	12.0%

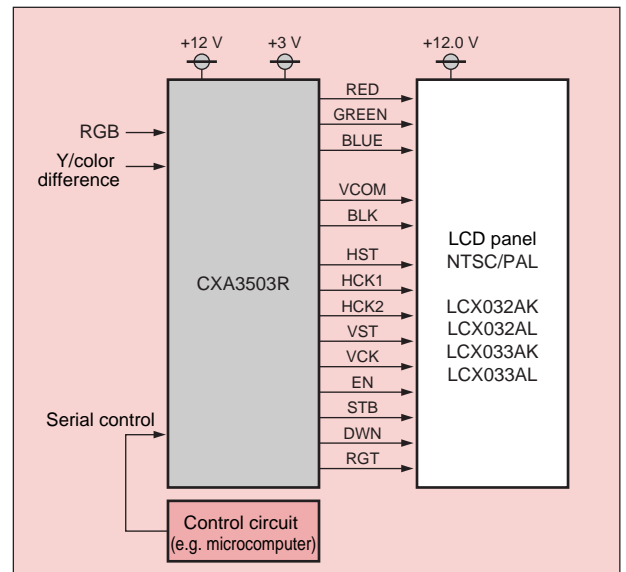

■ Figure 2 LCX032AK/AL and LCX033AK/AL System Block Diagram

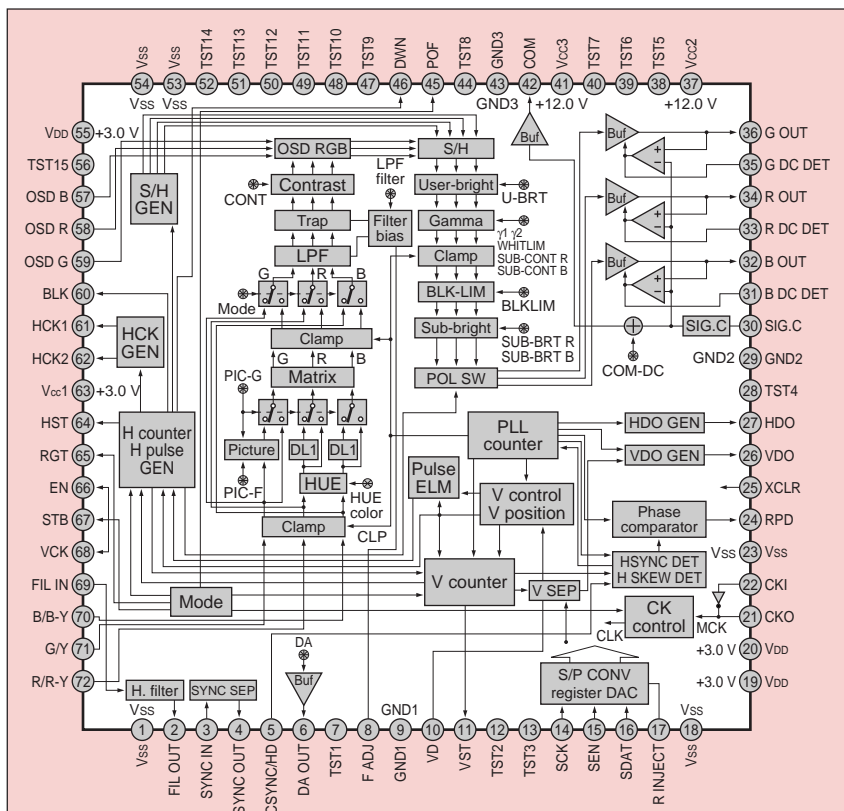

■ Figure 3 CXA3503R Block Diagram