

1/3-Inch CCD Image Sensors

## Super HAD CCD™

**250,000 and 290,000-pixel systems**

**ICX054BK (NTSC), ICX054BL (EIA), ICX055BK (PAL), ICX055BL (CCIR)**

**380,000 and 440,000-pixel systems**

**ICX058CK (NTSC), ICX058CL (EIA), ICX059CK (PAL), ICX059CL (CCIR)**

The 1/3-inch CCD has become the mainstream in areas such as the monitoring camera.

Sony has now brought its unique "Super HAD CCD" technology to the 1/3-inch CCD, and has developed CCDs with significantly improved sensitivity characteristics.

Since the number of pixels, the pin configuration, and the drive specifications are the same as in earlier products, these new CCDs can provide increased sensitivity and improved image quality in existing end products without requiring changes to those products.

- Supports 1/3-inch optical systems
- High sensitivity (+3 to +4 dB over earlier Sony products)
- High saturation signal (about +1 dB over earlier Sony products, for ICX054/055BK/BL only)
- Number of pixels, pin configuration, and drive specifications identical to those of earlier products

1/3-inch CCD devices are mainly used in monitoring cameras and in high-end camcorders. Since the use of these products in low-light situations is common, particularly in monitoring applications, there are strong desires for improvements in the basic characteristics of the CCDs used to provide increased end-product sensitivity and image quality. To respond to these desires, Sony is now providing a product line with significantly improved sensitivity by introducing the Sony's "Super HAD CCD" technology, which provides increased sensitivity to all versions in this series of 1/3-inch 250,000-pixel and 380,000-pixel CCD devices. (See figure 1.)

### ■ Super HAD CCD Technology

"Super HAD CCD" technology reduces, as far as possible, the ineffective areas between the on-chip microlenses formed over each pixel, and thus further increases the efficiency of utilization of the incident light to provide higher sensitivity. This technology significantly increases the CCD sensitivity characteristics, which are seen as the most important point for providing high performance in the end product. Photograph 1 presents enlargements comparing the on-chip microlenses in a Super HAD CCD with those of an earlier CCD.

### ■ Increased Sensitivity

The sensitivity of the 1/3-inch Super HAD CCDs in this release (the ICX054/055BK/BL and the ICX058/059CK/CL) are +3 to +4 dB higher than the sensitivity of Sony's earlier products (the ICX054/055AK/AL and the ICX058/059AK/AL). (See tables 1 through 4.)

### ■ High Saturation Signal Level

These 250,000-pixel CCDs, which have an especially high sensitivity (the ICX054/055BK/BL), also feature a saturation signal level increased by about +1 dB over that of earlier Sony products (the ICX054/055AK/AL). By providing both high sensitivity and a higher saturation signal level, these CCDs can contribute to improved image quality in end products. (See tables 1 and 2.)

### ■ Device Specifications

The number of pixels, the package, the pin configuration, and the drive specifications are identical to those of earlier products. These new CCDs can replace earlier CCDs in existing products and provide increased sensitivity and improved image quality without requiring changes to those products. (See figure 2.)

\*: Super HAD CCD™ is a trademark of Sony Corporation.

## V O I C E

The performance of 1/3-inch CCDs has been further increased by the introduction of Sony's "Super HAD CCD" technology. We are confident that this "Super HAD CCD" product will provide full satisfaction both to customers who are already using the current products, and to customers using this product for the first time.



# New Products

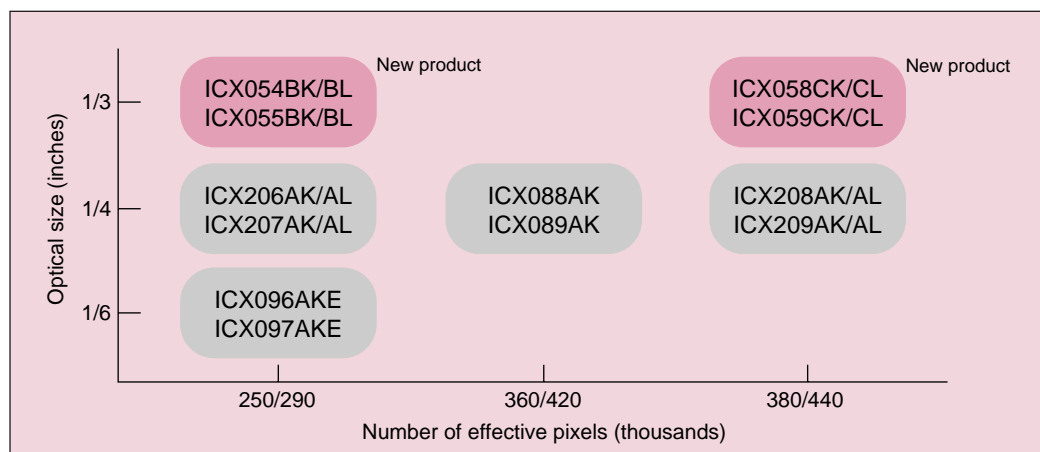

■ Figure 1 Super HAD CCD Product Line

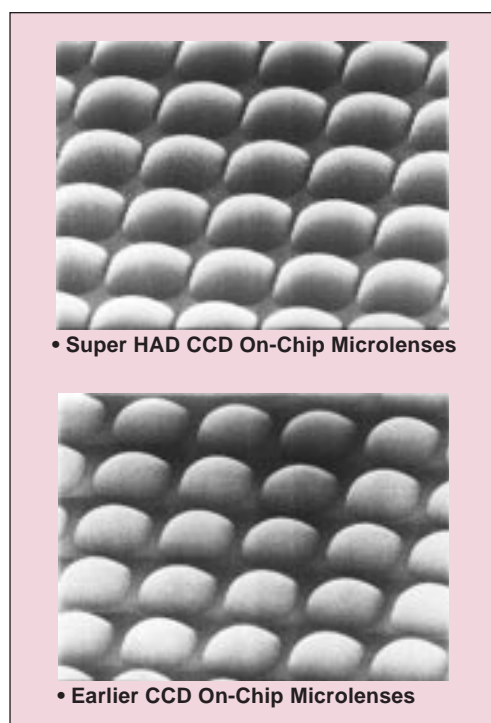

■ Photograph 1 Comparison of On-Chip Microlens Structures

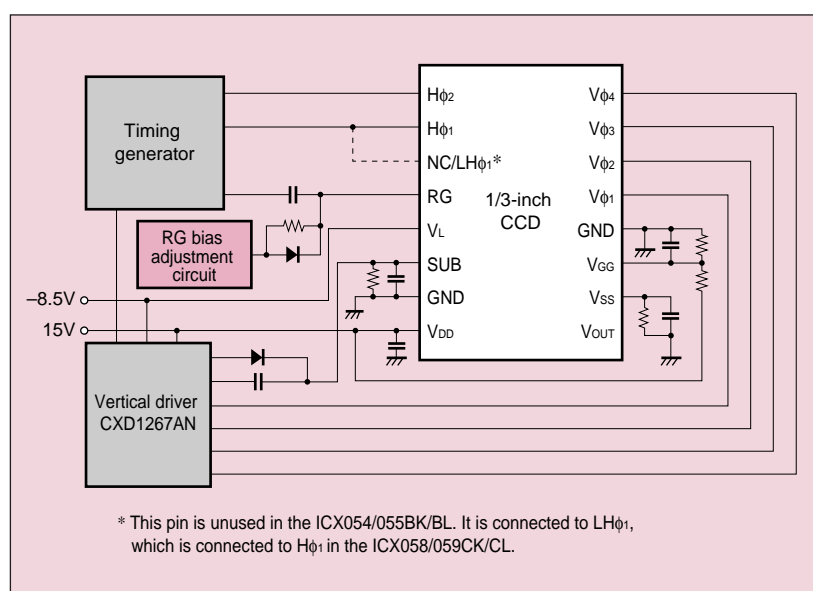

■ Figure 2 Driver Circuit Example

■ Table 1 Comparison of 250,000-Pixel Color CCD Specifications

	ICX054BK/055BK (New 1/3-inch CCD product)	ICX054AK/055AK (Earlier 1/3-inch CCD product)	Improvement
Sensitivity (F5.6)	970mV/940mV	700mV/630mV	About +3dB
Saturation signal level	800mV/720mV	700mV/630mV	About +1dB

■ Table 2 Comparison of 250,000-Pixel Black-and-White CCD Specifications

	ICX054BL/055BL (New 1/3-inch CCD product)	ICX054AL/055AL (Earlier 1/3-inch CCD product)	Improvement
Sensitivity (F8)	900mV/840mV	560mV/500mV	About +4dB
Saturation signal level	800mV/720mV	700mV/630mV	About +1dB

■ Table 3 Comparison of 380,000-Pixel Color CCD Specifications

	ICX058CK/059CK (New 1/3-inch CCD product)	ICX058AK/059AK (Earlier 1/3-inch CCD product)	Improvement
Sensitivity (F5.6)	460mV/460mV	340mV/330mV	About +3dB

■ Table 4 Comparison of 380,000-Pixel Black-and-White CCD Specifications

	ICX058CL/059CL (New 1/3-inch CCD product)	ICX058AL/059AL (Earlier 1/3-inch CCD product)	Improvement
Sensitivity (F8)	460mV/460mV	300mV/300mV	About +4dB