

The Industry's First On-Chip Logic Circuits and 3-V Drive Switching MMIC for Cellular Telephones

CXG1063TN CXG1064TN

Nowadays, it seems that people are using portable telephones everywhere. While this certainly is partly because of the efforts of portable telephone service providers to lower their rates, the advances in the portable telephones themselves has played a major role.

Sony has developed its own unique GaAs JFET technology that achieves both superlative high frequency response and low costs at the same time. Using this technology, Sony has developed and released a wide range of ICs that can help achieve portable telephone miniaturization and longer communication times.

With the supply of these components, Sony is contributing to the development of attractive portable telephones and to the spread of personal communication in our daily lives.

- On-chip logic circuits (CXG1064TN)
- 3-V operations (CXG1064TN)
- Ultraminiature 16-pin TSSOP package
- Low insertion loss

The antenna switch used in digital portable telephone terminals (PDC) in Japan's domestic market has the structure shown in figure 1. The antenna switch is a key device in these products and must switch 800-MHz and 1.5-GHz high-frequency signals with low loss. Miniaturization and low-voltage drive are strongly desired in this device. In earlier products, a duplexer filter or similar circuit was used. However, telephone manufacturers were dissatisfied due to the number of components and printed circuit board mounting area required. To respond to this need, Sony developed and released the CXG1024N/60N products, which integrate the

antenna switch in a single GaAs MMIC chip. These have been so well-received that they are now referred to as the industry standard. We have now developed two new products in this area: the CXG1063TN, which achieves package miniaturization, and the CXG1064TN, which integrates logic circuits on chip and allows 3-V drive.

■ Adoption of a 16-Pin Miniature TSSOP Package

IC package miniaturization is a critical point required in portable telephone terminal applications. Sony has developed a 16-pin TSSOP package that reduces the mounting area to about 1/2 of that required by the earlier 16-pin SSOP package. This new package has been adopted in the CXG1063TN/64TN. (See figure 2.)

■ On-Chip Logic Circuits

Sony, by taking advantage of the features of its unique GaAs JFET technology, has developed the industry's first digital/analog hybrid GaAs MMIC process for use in consumer products. Using this process, Sony has incorporated switch control logic circuits in the CXG1064TN.

Although a control IC is required when using the CXG1024N/60N products, the CXG1064TN achieves a significant reduction in mounting area, a reduction in the number of components required, and a reduction in the total system cost

by incorporating this control circuit on chip. (See figure 2.)

■ Achievement of 3-V Drive

Although antenna switches previously required 5-V drive and a negative power-supply voltage, due to optimization of the bias circuit and other technical improvements, the CXG1064TN achieves 3-V drive in a cellular MMIC switch for the first time in the industry. Thus the power supply components associated with a DC-DC converter are no longer required. As can be seen from figure 3, the CXG1064TN provides fully adequate characteristics, even at a 3-V drive voltage. Another important point is a reduction in insertion loss. This is because the insertion loss strongly influences the length of time where a portable telephone can operate. Figure 4 shows the insertion loss characteristics of the CXG1063TN. Optimization of the circuit structures enabled Sony to achieve the ultralow insertion loss of about 0.3 dB at 800 MHz in this product.

■ Future Developments

Although Sony is convinced that the CXG1063TN/64TN is a leading-edge IC that is several generations ahead of the products of other manufacturers in a wide range of aspects, we are still not satisfied and will continue to strive for improved characteristics and improved ease of use.

V O I C E

High-frequency ICs cannot be designed just using circuit simulation alone. One has to take the whole system into consideration: the circuit, the IC pattern layout, the package, and everything else. Only then, and by incorporating all one's experience and know-how, can one create a superlative IC. I believe that MMIC design is like creating a work of art: it is extremely important to cultivate your sensitivity on a daily basis and to maximize your powers of concentration when working on a design. The CXG1063TN and CXG1064TN are the product of this kind of effort.



New Products

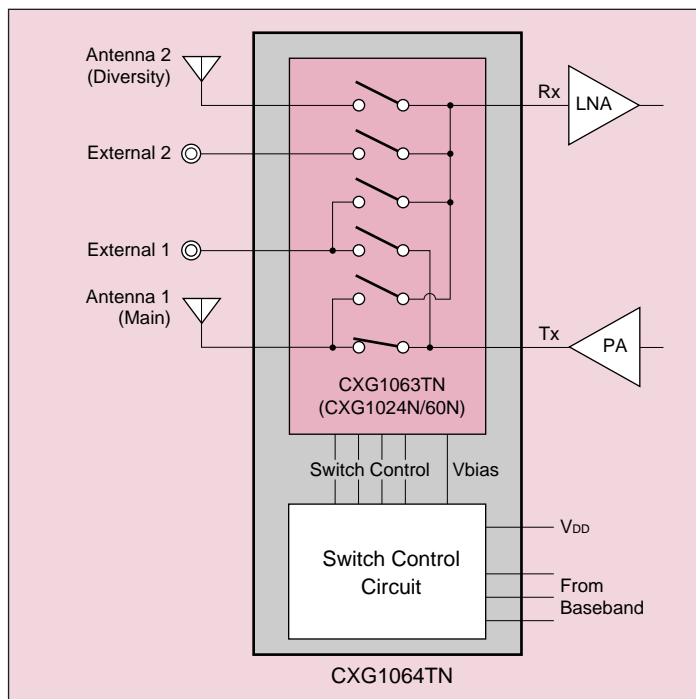

■ Figure 1 PDC Terminal Antenna Switching Block

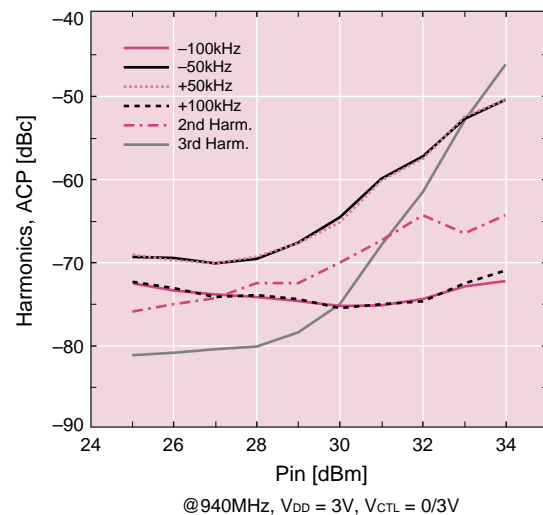

■ Figure 3 CXG1064TN APC and Higher Harmonics

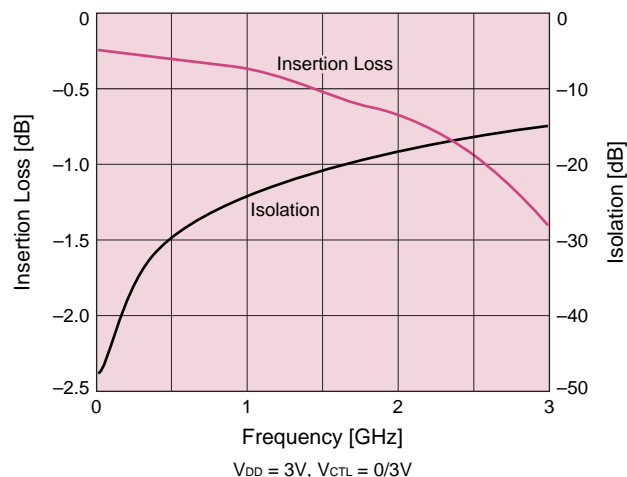

■ Figure 4 CXG1063TN Insertion Loss and Isolation vs. Frequency Response

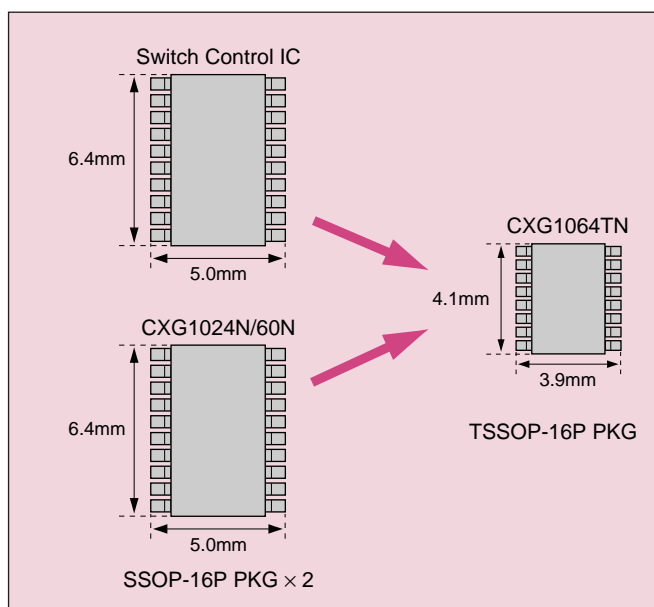

■ Figure 2 Mounting Area Comparison between the CXG1024N/60N (+ Switch Control IC) and the CXG1064TN

■ Table 1 Comparison of the CXG1024N/60N, CXG1063TN, and CXG1064TN Characteristics

	CXG1024N/60N	CXG1063TN	CXG1064TN
Insertion Loss (RF3 – RF4)	0.4dB	0.3dB	0.4dB
Isolation (RF3 – RF4)	21dB	24dB	24dB
P1dB (RF3 – RF4)	35dBm (0/4V Control)	36dBm (0/4V Control)	37dBm ($V_{DD} = 3.5V$)
Package	SSOP-16 pins	TSSOP-16 pins	TSSOP-16 pins
Control Logic Circuit	×	×	○
ESD Protection for Control	×	○	○