

## Digital Still Camera CCD that Easily Achieves Brilliant Images with No Camera Blur

# Wfine CCD™

- Progressive scan readout method
- Primary color filters
- Square pixels

Wfine CCD™ is a trademark of Sony Corporation.

The recent growth in the digital still camera market has been phenomenal. Along with this growth, the trend towards larger numbers of pixels in the CCDs used has accelerated, with the VGA 330,000-pixel CCD giving way to the XGA 800,000-pixel CCD. This has increased the range of applications for these products, further fueling market growth. In particular, printer performance has improved, and now the use of digital still camera images is not limited to display on the personal computer screen, but has expanded to include printout as well. The result is that there are now even stronger desires for increased image quality in digital still cameras. Sony believes that it is not only the number of pixels in the CCD that determines image quality, and has developed and released commercial CCD products that adopt the progressive scan readout method that is optimal for digital still cameras and that provide superlative basic device characteristics.

Given this background, Sony has coined the term “Wfine” (double fine) to refer to CCDs that meet the following three conditions. First, these CCDs must

adopt the progressive scan readout method which minimizes the effects of camera blur. Second, these CCDs must adopt primary color filters for brilliant images. Finally, these CCDs must provide a square pixel geometry for compatibility with computer applications.

Such CCDs do not require the complexities and difficulties associated with mechanical shutters, frame memory, and pixel shape conversion, thus simplifying camera design. Furthermore, the use of primary color filters allows cameras to achieve faithful color reproduction, which is crucially important for digital still cameras.

Digital still cameras are a product that can achieve the dream of capturing the happy, felicitous, and emotionally charged moments in our lives as still images. Due to being both immediate yet also supporting flexible processing later, digital still photography is expected to continue to grow. These CCDs allow cameras to be designed easily and can provide the best performance at a given number of pixels. We strongly recommend Wfine CCDs for digital still cameras.

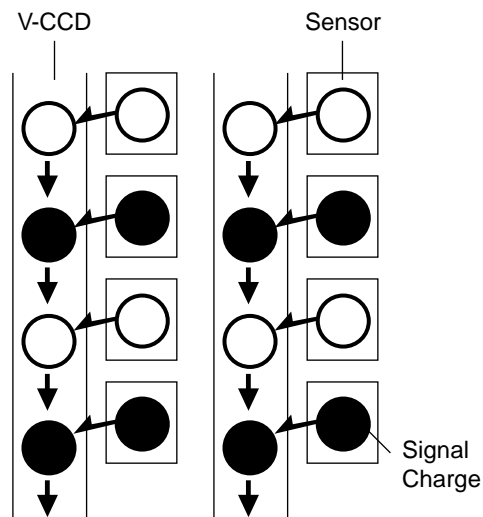

■ Figure 1 Progressive Scan Readout Method

# Wfine CCD™

W ... Refers to devices having double (W) resolution in the vertical direction (V), and thus double the value.  
 fine ... Indicates fine grained, beautiful, and advanced.

Sony has coined the term Wfine (double fine) CCD to refer to digital still camera CCDs that meet the following three conditions.

## 1. Progressive scan readout for blur-free photographs

Unlike the interlaced readout technique used in camcorders, the progressive scan readout method does not require either a mechanical shutter or a frame memory, and provides full-frame still images directly. Since all the pixel signals can be output independently, a high vertical resolution is provided. (See figure 1.)

## 2. Primary color filters for brilliant images

As compared to the complementary color filters used primarily in camcorders, primary color filters used primarily in digital still cameras provide higher color reproducibility and high color saturation for truly red roses and lifelike skin tones, thus providing more realistic reproduction.

## 3. Square pixels for a good match with digital systems

A square shape as the pixel geometry simplifies image processing. (See figure 2.)

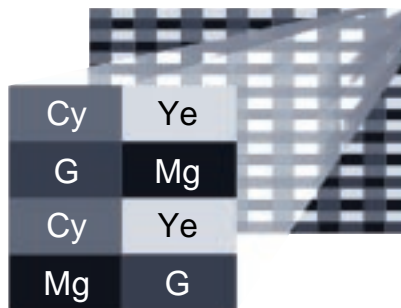

Camcorder CCD  
 (Complementary color filters and rectangular pixels)

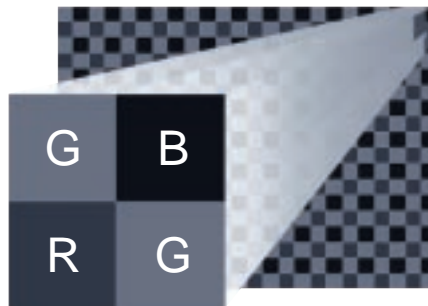

Digital still camera CCD  
 (Primary color filters and square pixels)

# Enabling High-Quality Printed Output 1/3-Inch 800,000-Pixel Wfine CCD ICX204AK

- **Wfine CCD**
  - Progressive scan readout
  - Primary color filters
  - Square pixels
- **800,000 pixels (1034 (H) × 779 (V))**
- **High sensitivity and low smear**
- **Provides a high-speed draft mode which operates at three times the normal vertical scan rate by using line selection**

## 1. 800,000-pixel Wfine CCD

The VGA 330,000-pixel class is appropriate for images included on web pages. This resolution is fully adequate for images displayed on a personal computer monitor. However, the ICX204AK targets the next higher class, that is, the 800,000-pixel CCD, which provides adequate image quality for creating personalized Christmas, New Years, or other postcards. (See figure 3.) A market survey showed that this was the class device for which the demand is largest. To retain compatibility with the 1/3-inch optical systems widely used in consumer products, we reduced the size of the individual pixel to have a diagonal of 4.65 μm and achieved an 800,000-pixel device without any degradation of basic device characteristics. (See table 1.)

## 2. High-sensitivity low-smear 4.65-μm diagonal pixel element

By optimization of the pixel pattern, the fabrication process, and the shape of the on-chip microlenses, we achieved a significant increase in sensitivity per unit area in the ICX204AK as compared to current Wfine CCD products. (See figure 4.) This resulted in the achievement of the high sensitivity of 400 mV despite a reduction in the size of the unit pixel to 4.65 μm. This device also achieves a smear characteristic of -100 dB, and thus can contribute to increased image quality in digital still cameras. (See table 2.)

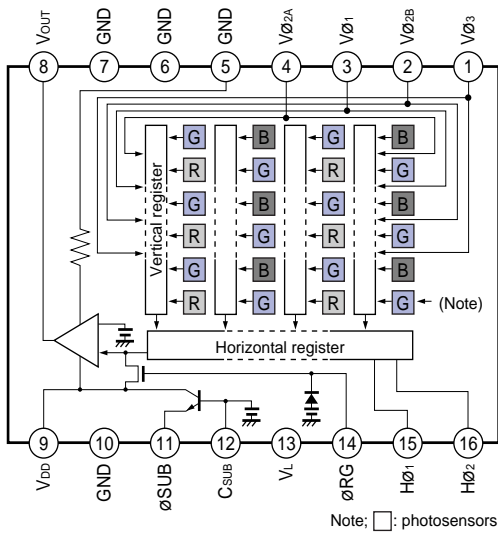

■ Figure 3 Block Diagram and Pin Configuration

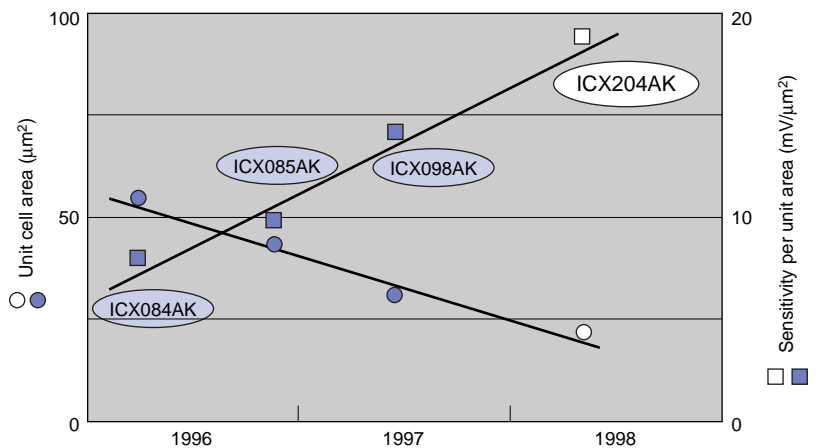

■ Figure 4 Increasing Sensitivity in Wfine CCD Sensors

■ Table 1 Pin Structure

Item	ICX204AK
Optical size	1/3-inch format
Format	4 : 3
Transfer method	Progressive scan
Total number of pixels	1077 (H) × 788 (V) - About 850,000 pixels
Number of effective pixels	1034 (H) × 779 (V) - About 800,000 pixels
Number of active pixels	1024 (H) × 768 (V) - About 790,000 pixels
Color coding	Green checker, R/B line sequential
Chip size	5.80mm (H) × 4.92mm (V)
Unit cell size	4.65μm (H) × 4.65μm (V) - Square pixels
Maximum horizontal drive frequency (independent CCD)	20MHz
Package	16pin DIP (Plastic)

■ Table 2 Image Characteristics

Item	ICX204AK	Remarks
G sensitivity (F5.6)	400mV	3200K, 706cd/m <sup>2</sup> 1/30s accumulation mode
Sensor saturation signal level	450mV	
Smear (F5.6)	-100dB	V/10 method 1/20s accumulation mode
Maximum frame rate (independent CCD)	20frame/s	

### 3. High-speed draft mode

The ICX204AK also provides a high-speed draft mode in which 256 lines (vertically) of the effective area are output. (See figure 5.) Since this mode allows vertical scanning to be performed at three times the normal speed, it can contribute to smooth LCD monitor output and increased speed in TTL-type AE, AWB, and AF routines.

### 4. Timing generator IC

At the same time as developing the ICX204AK, Sony also developed the CXD2457R timing generator IC. This IC supports high-speed draft mode and provides on-chip vertical drivers. (See figure 6.)

## Future Developments

The digital still camera has grown as a personal computer peripheral device. In the current worldwide market, the 1/3-inch 330,000-pixel CCD (ICX084AK) is most commonly used in consumer products, and the 2/3-inch 1,300,000-pixel CCD (ICX085AK) is most commonly used by photographic studios and in other professional applications. Sony released commercial products of both types in 1996. In early 1997, Sony developed and released a 1/4-inch 330,000-pixel CCD product (ICX098AK) to support even more compact products appropriate for portable use.

In the spring of 1998, Sony will release the 1/3-inch 800,000-pixel ICX204AK, which is targeted at the consumer

market for high image quality printing. (See figure 7.) The infrastructure necessary for providing printing services from memory cards instead of silver-based photographic film at photofinishing retailers is almost in place, and this will allow consumers to use digital still cameras freely. In the future, not only will it be possible to edit images on a personal computer, but the pleasures provided by printed output will increase.

Sony is committed to constantly striving to create CCD products that achieve improvements in both of the basic CCD characteristics, resolution and sensitivity, at the same time to achieve well-balanced CCD products. Sony will continue to strive for both improved image quality and miniaturization in high-performance CCD products to contribute to the growth of the digital still camera.

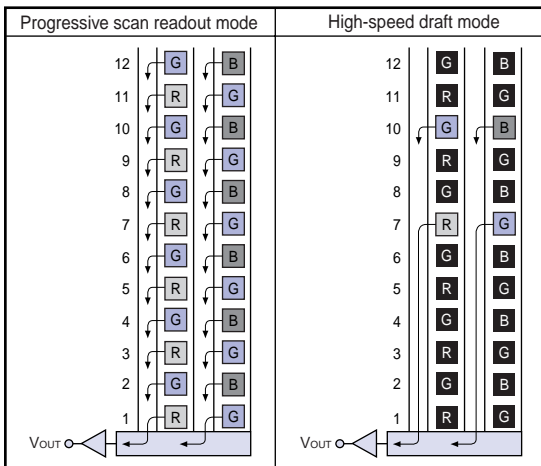

Note: The pixels in the figure drawn in black are pixels that are not read out. In high-speed draft mode, readout starts with the seventh line.

■ Figure 5 High-Speed Draft Mode

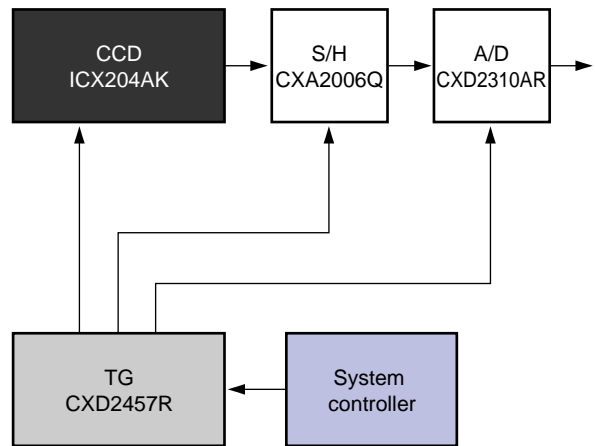

■ Figure 6 System Configuration Example

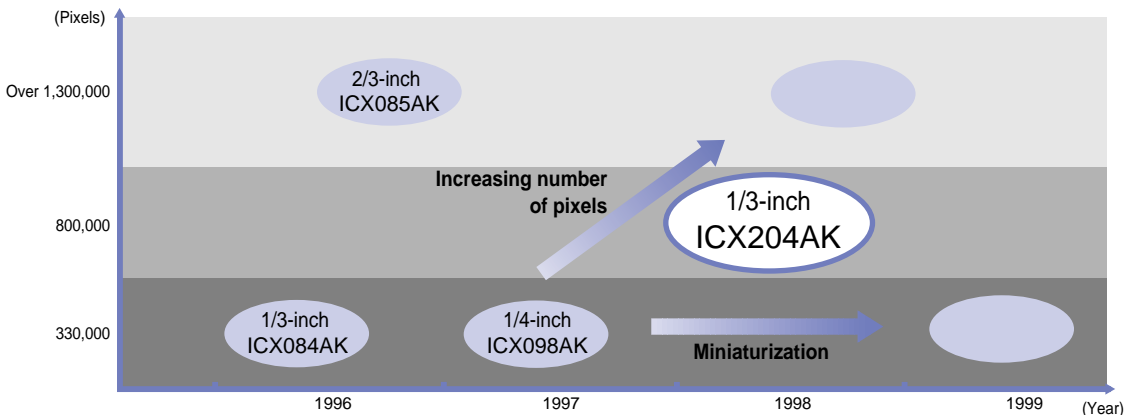

■ Figure 7 Trends in Wfine CCD