

# CXD2930AR

With the increasing popularity of in-car navigation systems, the GPS (global positioning system), which uses satellites, has become indispensable. The CXD2930AR is a special-purpose processor for GPS products.

This LSI, which Sony developed using system-on-silicon technology, integrates a 32-bit RISC CPU, SRAM, a UART, and other functions necessary for GPS applications on a single chip. This allows a miniature, high-performance, low-power GPS receiver to be implemented with just three chips, an RF LSI, external ROM, and the CXD2930AR itself.

While in-car navigation systems go without saying, this allows the CXD2930AR to be used in a wide range of end products, including portable telephones, personal computers, and cameras.

- Sony-developed high-performance 32-bit RISC CPU
- Sixteen-channel parallel GPS receiver for simultaneous reception from 16 GPS satellites
- All-in-view
- Two-satellite position measurement
- Differential GPS

## ■ Sony-Developed High-Performance 32-bit RISC CPU

The CXD2930AR incorporates a Sony-developed high-performance 32-bit RISC CPU, a UART, SRAM, a real-time clock, and the interval timer required for software development, and thus includes on chip all the functions required in a GPS receiver. The CXD2930AR allows anyone to create a high-performance GPS receiver with a small number of external components (an RF IC, the CXD2930AR itself, and external ROM) by using Sony-provided GPS software.

## ■ Sixteen-Channel GPS Receiver

Since only eight of the GPS satellites can be seen at one time from any given point on the surface of the earth, eight channels is adequate, and, in fact, only four channels are required for measurement. However, the TTFF\*<sup>1</sup> is reduced to 1/2 that of earlier Sony products by providing 16 channels.

## ■ All-in-View

Normally, the current position can be measured if at least three GPS satellites are received, although four are required for three-dimensional positioning. "All-in-view" is a positioning technique that uses all of the GPS satellites whose signals can be received. This can improve the position measurement precision lost by SA\*<sup>2</sup>, and reduces the frequency of current position jumping due to switching of the satellites used for positioning.

## ■ Two-Satellite Measurement

Although the current position can be determined if the signals from at least three GPS satellites can be received, two-satellite measurement is a technique that allows the current position to be determined in some situations, such as streets with many tall office buildings, where the signals from only two satellites can be received. This can increase the position measurement precision that can be measured.

## ■ Differential GPS

The CXD2930AR adopts the DARC FM multiplex differential GPS system. This system allows the position precision to be increased by about a factor of ten over independent GPS measurement by combining the GPS system with an FM multiplex receiver unit.

\*<sup>1</sup> TTFF: Time To First Fix (The time from the point power is turned on to the point the first position measurement is taken.)

\*<sup>2</sup> SA: Selective Availability (Intentional degradation of position measurement precision to prevent military application by general users.)

## V O I C E

When developing this LSI, I wanted to create the world's smallest and highest-performance GPS receiver. I believe that this product achieves one of the circuits with the smallest number of external components of the currently available GPS receiver circuits. I'm proud that from a performance standpoint this device is also outstanding. In the future I'd like to design the ultimate single-chip GPS receiver.



# New Products

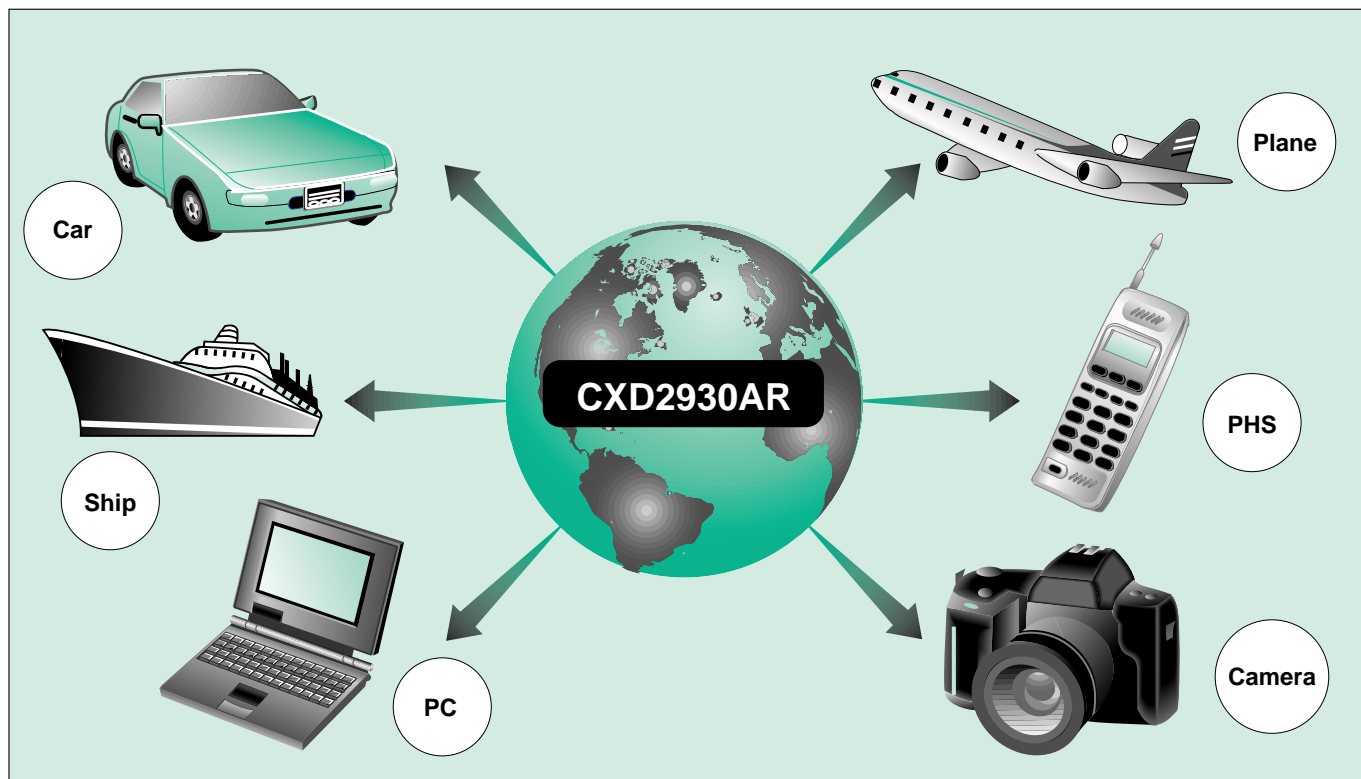

■ Figure 1 GPS Applications - The Limitless Expanding World of GPS

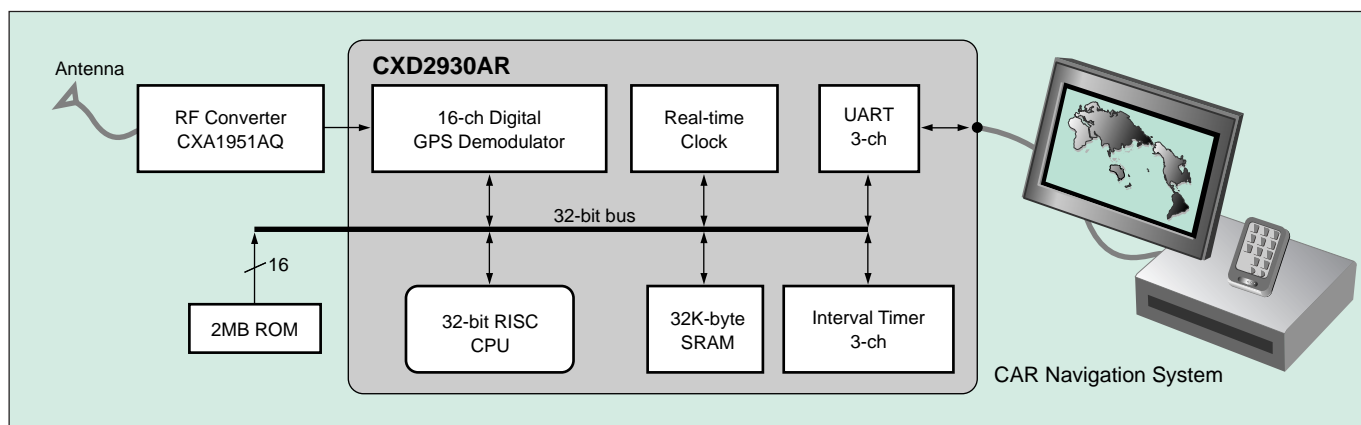

■ Figure 2 System Structure

■ Table 1 Time until First Measurement after Power On

Hot Start Within 2 hours after the power was turned off (Both Ephemeris and Almanac valid)	< 20 seconds
Warm Start Over 2 hours after the power was turned off (Ephemeris invalid, Almanac valid)	< 40 seconds
Cold Start (Both Ephemeris and Almanac invalid)	< 120 seconds

■ Position Measurement Precision

· Stand-alone (independent GPS)

1  $\sigma$  (68%) : < 30m  
3  $\sigma$  (98%) : < 90m

· DGPS (Differential GPS)

1  $\sigma$  (68%) : 6m  
3  $\sigma$  (98%) : 18m