

High Luminance, High Image Quality, and High Resolution Achieved in Single-Panel LCD Panels

Single-Panel Color Projection TV LCDs

LCX011AM

LCX019AM

Due to their superlative features and characteristics, including thin form factors, light weight, high color reproducibility, sharp images, registration adjustment that is either simple or unnecessary, and immunity from the influence of magnetic fields, LCD color projection TV has recently become the focus of much attention.

Sony has now developed two new miniature single-panel color LCD panels for projection TV, the LCX011AM (1.43-inch, 16:9 aspect ratio) and the LCX019AM (1.32-inch, 4:3 aspect ratio). These panels achieve excellent image quality, high luminous images, and high resolution, and feature superlative cost-performance ratios. Since these are single-panel products, they can provide significant cost reductions, especially in the optical engine and driver ICs, and can contribute to increased popularity of LCD color projection TV.

- High transmittance achieved by the use of Sony's unique built-in microlenses. (120 ANSI lm/100-W metal-halide lamp)
- Achievement of the industry's highest horizontal resolution for a single-panel product: 600 TV lines
- Rich set of on-chip functions
- Horizontal and vertical drivers built in (On-chip input level conversion circuits allow these products to be driven from 5-V timing signals.)
- Significant cost reductions in end products, especially in the optical engine and the driver ICs.

■ High Transmittance Achieved by the Use of Sony's Unique Built-In Microlenses

The LCX011AM and LCX019AM achieve high transmittance by using a Sony's unique technology that incorporates microlenses on the opposite side of the substrate from the TFT devices to handle the fine pattern formed by the high-temperature polysilicon TFT devices. Figure 1 presents a cross-sectional model of the microlens geometry. Light that has been color separated by dichroic mirrors and a diffraction grating is distributed and focussed onto the pixels corresponding to R, G, and B by the microlenses that are formed with a ratio of one microlens

for each 3 pixels. Since this system does not use color filters, there is no absorption of light by color filters and furthermore due to the focusing effect of the microlenses, these products provide increased luminance despite being miniature single-panel devices. These products achieve an aperture ratio of 70% or higher and an optical transmittance of 24% (for an optical divergence angle of 3.5°), and thus achieve a 120 ANSI lm rating with a 1.4-mm arc length 100-W metal halide lamp.

■ Achievement the Industry's Highest Resolution for a Single-Panel Product: 600 TV Lines

Table 1 lists the characteristics of the LCX011AM and LCX019AM. Although these panels have exactly the same outside dimensions as earlier 1.3 to 1.35-inch panels, due to the use of Sony's unique TFT fine fabrication technology and advanced on-chip black technology, these panels have a total of 768,000 dots (LCX011AM) and 576,000 dots (LCX019AM) in a delta arrangement, and achieve high definition with a horizontal resolution of 600 TV lines. These panels also include the image quality enhancing circuits used previously and provide high-quality images with no lines, irregularities, ghosts, or cross talk, and also a high contrast ratio of 200:1 or more.

■ Rich Set of Built-In Functions

The LCX011AM provides the following built-in functions. (See table 1 and figure 2.)

- Support for the NTSC, NTSC-WIDE, PAL, and HD (20-MHz band) formats.
- Switching between the 16:9 and 4:3 aspect ratios. (Displays a 4:3 screen by side black circuit.)
- Up/down and/or right/left inversion functions.

■ Significant Cost Reductions

LCD color projection TV systems are ready to become a large market. However, cost reduction is a major precondition for achieving that goal. Since the LCX011AM and LCX019AM are single-panel formats, they can provide reductions in the panel cost itself, reductions in the number of system IC components (figure 3), and reductions in parts counts in and simplifications of the optical engine. Thus we can hope for market growth provided by LCD color projection TV systems with excellent cost-performance ratios.

V O I C E

These products were developed with the idea of achieving the dream of an affordable 40-inch class LCD wide-aspect-ratio TV that provides beautiful video with excellent image quality, a thin form factor, and light weight. Furthermore, since the LCX011AM and LCX019AM can also be used in other applications, we are looking forward to our customers investigating their use in a wide range of areas. By the way, when used in black-and-white systems, or in three-panel systems, these products can provide a horizontal resolution of 900 TV lines. Additionally, Sony also provides single-panel optical engines that use these LCD panels.



New Products

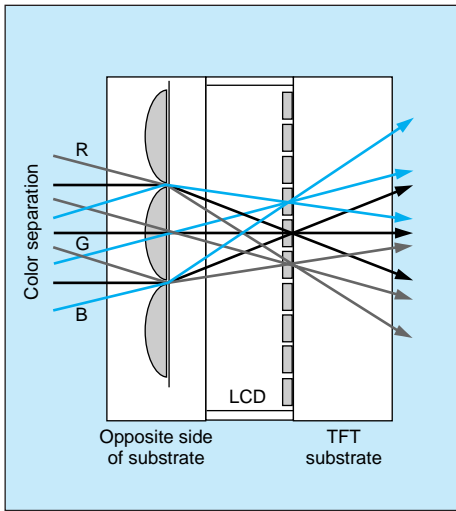

■ Figure 1 Cross-Sectional Model of the Microlens Geometry

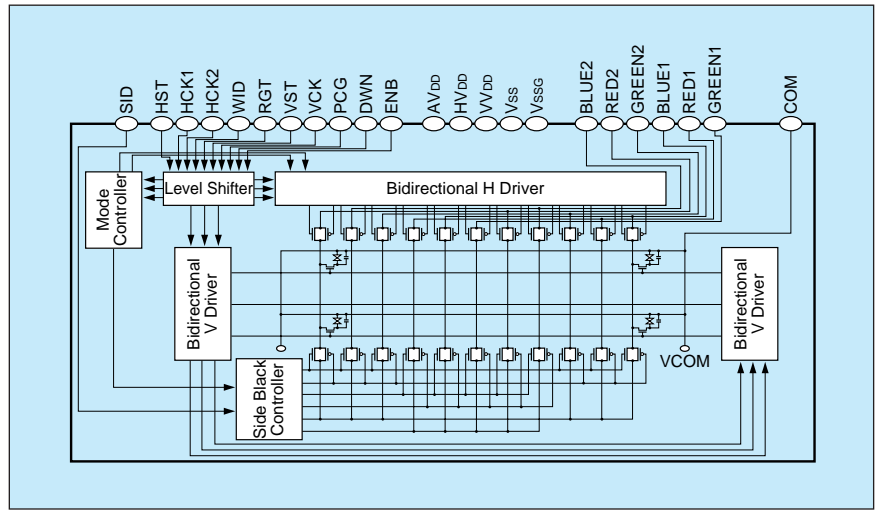

■ Figure 2 LCX011AM Block Diagram

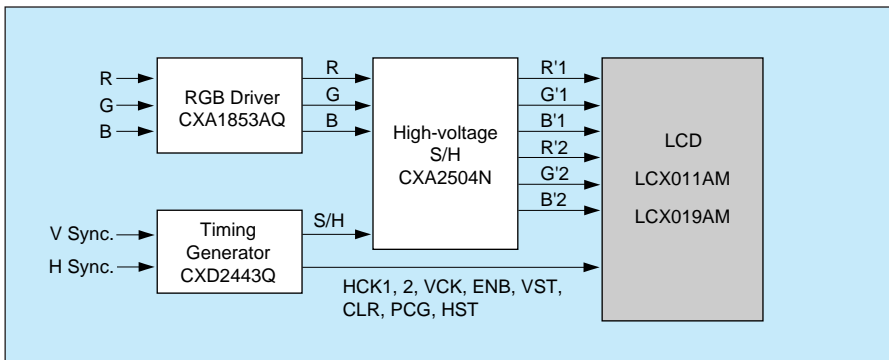

■ Figure 3 Sample System Structure

■ Table 1 LCX011AM and LCX019AM Characteristics

Item	LCX011AM	LCX019AM
Screen size	1.43-inch diagonal	1.32-inch diagonal
Screen aspect ratio	16 : 9	4 : 3
Chip size	37.02mm (H) × 25.82mm (V)	32.73mm (H) × 26.03mm (V)
Number of effective displayed dots	For 16:9 display: 1600 (H) × 480 (V) For 4:3 display: 1200 (H) × 480 (V) Total dots: 768,000	1200 (H) × 480 (V) Total dots: 576,000
Display area	31.68mm (H) × 17.76mm (V)	26.88mm (H) × 20.064mm (V)
Pixel arrangement	RGB delta arrangement	
Drive method	1H inversion	
Signal input method	Simultaneous 6-dot RGB sampling	
Clock input voltage	5.0V (Level conversion circuits are built in.)	
Effective aperture ratio	70% or higher (45.3%)	70% or higher (47.4%)
Main functions	<ul style="list-style-type: none"> • NTSC, NTSC-WIDE, HD (20 MHz), and PAL • Up/down and/or right/left inversion • Switching between the 16:9 and 4:3 aspect ratios 	<ul style="list-style-type: none"> • NTSC and PAL • Up/down and/or right/left inversion
Horizontal resolution	600 TV lines	
Brightness	150 ANSI lm or better with a 1.4-mm arc length 100-W metal halide lamp	
Contrast	200:1 (typ.)	