

The Industry's First Gigabit Ethernet Transceiver Optical Communication IC

CXB1584Q

Have you ever felt that the 10-Mbps Ethernet you are using is too slow?

Standardization of the 1-Gbps data transfer rate gigabit Ethernet ultrahigh-speed LAN is progressing rapidly under IEEE 802.3.z, which is the Ethernet standardization organization.

The CXB1584Q was presented *1 at the IEEE 802.3.z interim meeting in MAY 1996 as a gigabit Ethernet transceiver, and the CXB1584Q's superb performance was recognized by the industry.

Sony's technology is contributing significantly to the achievement of a gigabit Ethernet.

- Supports an Ethernet with a gigabit data transfer rate
- Data transfer rate: 1.25 Gbps
- Transceiver functions (10-bit P/S conversion, S/P conversion)
- Single 3.3-V power supply and a power consumption of 1 W (typ.)
- 80-pin QFP plastic package

Note:

The details of this presentation may be accessed either at Sony's homepage or at the IEEE 802.3 ftp site.

• Sony Home Page

http://www.sony.co.jp/ProductsPark/Professional/SC-HP/T_Paper/PDF/MYB1584.pdf

• IEEE 802.3 ftp site

ftp://stdsbbs.ieee.org/pub/802_main/802.3/gigabit/presentations/may1996/MYB1584.pdf

■ The Superlative Characteristics Required to Implement a Gigabit Ethernet

The CXB1584Q is a gigabit Ethernet transceiver whose basic functions conform to the ANSI X3T11 Fibre Channel (FC-0) standard. The main circuit components in the CXB1584Q include a 1.25-GHz PLL, a 10-bit parallel-to-serial converter that supports a 1.25-Gbps data transmission rate. (See figure 1.) The CXB1584Q achieves superlative performance in large part due to the low-jitter high-performance PLL used to generate the transmission clock and to recover the reception clock and data. (See figures 2 and 3.) More detailed information is available on Sony's home page and the IEEE 802.3 ftp site.

■ A Rich Set of Functions that Support Design and Maintenance

The lock detection functions for each of the transmission and reception PLL circuits are useful in assuring transmission reliability. The CXB1584Q also provides a selector function that can monitor the transmission data and clock and the data and clock recovered in reception. This function can contribute to end product development, design, and maintenance. The reference clock applied to the CXB1584Q can be selected to be either a single-phase 125-MHz clock or a two-phase 62.5 MHz clock. Since only rising edges on the two-phase clock are used, there are no strict limitations on the duty ratio used. If it is difficult to provide a 125-MHz clock at TTL levels, system design can be made easier by selecting the 62.5 MHz clock, and noise due to the reference clock can be reduced significantly. The CXB1584Q includes an on-chip byte synchronization detection function (+ Comma detection) and an on-chip test pattern generation function ($\pm K28.5$), and is designed to conform with the ANSI X3T11 Fibre Channel (FC-0) that applies 8B10B conversion to the transmitted data. It also provides an on-chip loopback function.

■ A Gigabit Network at an Attractive Price

All inputs and outputs are TTL/ECL compatible. The device operates from a single 3.3-V power supply, and we succeeded in holding power consumption to 1 W. This low power consumption allows an 80-pin plastic QFP package (with 14-mm sides) to be used and the CXB1584Q can be provided at an attractive price.

■ Standard Specifications Version: the CXB1589R

An IEEE 802.3.z standard specifications version of this device is available as the CXB1589R, which is provided in a 64-pin package.

V O I C E

"How fast is 1.25 Gbps?"

"Well, consider how long it takes for a fastball to get from the point it leaves the hand of a top-ranked pitcher, such as Hideo TORNADO Nomo of the Los Angeles Dodgers in National League, to the point it reaches the catcher's glove. At 1.25 Gbps, an Ethernet could transfer 100 million zeros and ones in that amount of time."

"Are there any ICs that can transmit or receive data that rapidly?"

"Just one: the CXB1584Q."



New Products

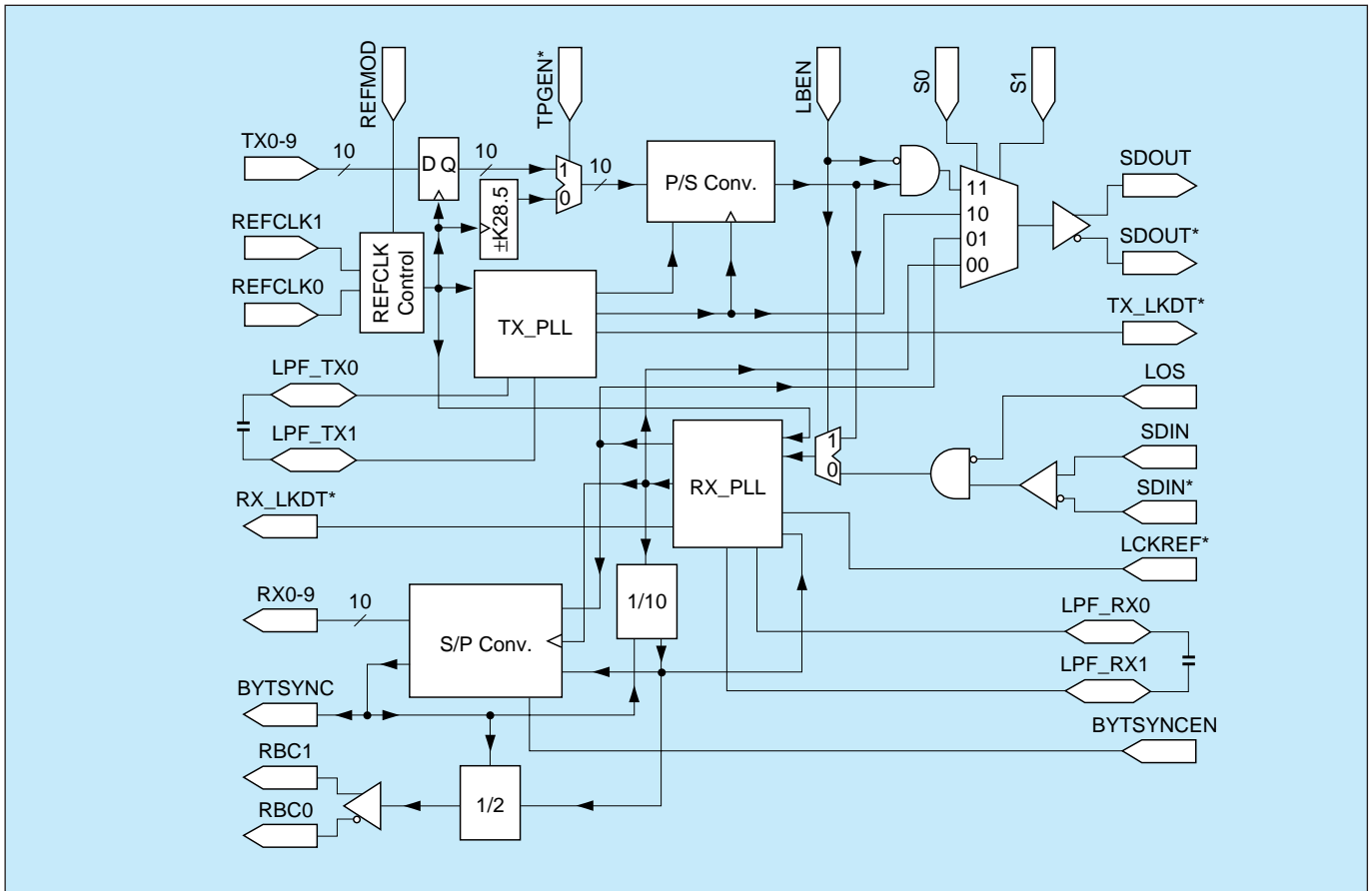

■ Figure 1 CXB1584Q Block Diagram

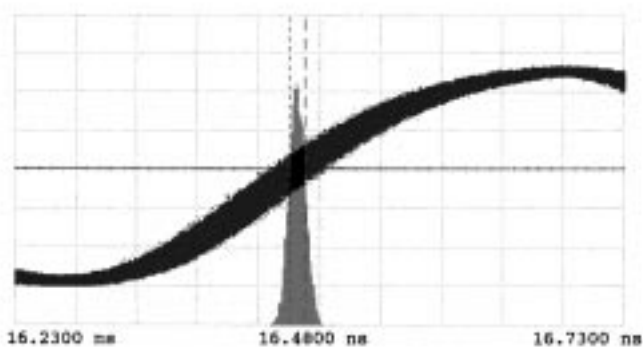

- Ch.1=200.0mV/div
- Offset=680.0mV
- Timebase=200ps/div
- Delay=16.6040ns
- DeltaV=712.50mV
- Vmarker1=362.50mV
- Vmarker2=1.0750V
- DeltaT=800.0ps
- start=17.2160ns
- stop=18.0160ns

TriggeronExternalatPos.Edgeat-60.00mV

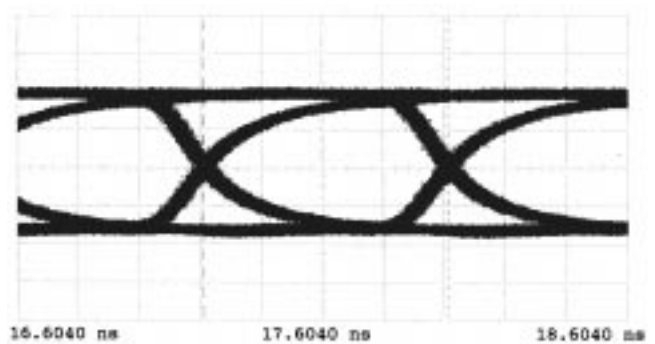

- Ch.1=100.0mV/div
- Offset=722.5mV
- Timebase=50.0ps/div
- Delay=16.2300ns
- Delta/Windo=3.1250mV
- Window1=725.00mV
- Window2=721.87mV
- Delta%=66.59%
- Upper=85.30%
- Lower=18.71%
- DeltaT=13.4ps
- Start=16.4682ns
- Stop=16.4548ns
- #Samples=5000
- Mean=16.4615ns
- Sigma=6.7ps

TriggeronExternalatPos.Edgeat153.0mV

■ Figure 2 CXB1584Q Reception Data

■ Figure 3 CXB1584Q Recovery Clock Random Jitter