

Transmission of Up to SXGA Images Over a Single Pair of Differential Signals GVIF (Gigabit Video Interface)

CXB1451Q CXB1452Q

The data handled by computers is digital. What is the best method for sending that data to digital display devices such as LCD and plasma displays? Clearly, it is best to send digital data serially as digital data.

The GVIF (Gigabit Video Interface), which is the crystallization of Sony's ultrahigh-speed digital serial transmission technology, enables transmission without degradation of high-quality images over long, flexible, and inexpensive cables.

- Supports the VGA, SVGA, XGA, and SXGA display modes
- Supports up to 260,000 display colors (up to 512 colors for SXGA)
- On-chip equalizer automatically corrects cable attenuation characteristics
- On-chip cable driver
- Supports both 1-pixel/shift clock and 2-pixel/shift clock operation
- Single 3.3-V power supply, low power consumption
- 80-pin QFP package

The CXB1451Q and CXB1452Q form a digital data serial transmission chip set for 18-bit color (about 260,000 colors) VGA, SVGA, or XGA or 9-bit color (512 colors) SXGA video signals. Figure 1 shows the block diagrams for these chips. The CXB1451Q is a transmitter IC that includes an encoder, parallel-to-serial converter, and a cable driver and the CXB1452Q is a receiver IC that includes a cable equalizer, serial-to-parallel converter, and decoder.

■ GVIF (Gigabit Video Interface) Features

Table 1 lists the display modes supported by the CXB1451Q/CXB1452Q chips. In this system, the 18 bits of pixel data, the 2-bit synchronous signal (H/V) used for image display, and the 4 bits of control signal used for video display are transmitted as a pair of small-amplitude differential signals. The transmission rate is up to 1560 Mbps. These chips are appropriate for twin-ax cable with a 100-Ω impedance. These chips encode the transmitted data to maintain DC balance and provide stable transmission.

■ Easy Interface with LCD Modules and Peripheral Circuits

All digital inputs and outputs are TTL/CMOS compatible. Also, these chips support both 1-pixel/shift clock and 2-pixel/shift clock operation. A single 3.3-V power supply is used and both chips feature low power consumption. Both chips are provided in 80-pin QFP plastic packages with 14-mm sides.

■ On-Chip Cable Driver and Equalizer Circuits

The CXB1451Q includes an on-chip low-voltage differential signal cable driver and the CXB1452Q includes an on-chip automatic correction equalizer. This allows these chips to form an inexpensive yet high-quality transmission system over a single-pair differential signal cable for flat panel displays such as LCD monitors. Since the cable equalizer automatically corrects the cable attenuation characteristics that depend on the length of the cable used, any cable length up to 10 meters can be used. (See figure 2.)

V O I C E

Have you ever wondered why personal computer monitor cables were so thick and short? It turns out that monitor cables carry ten thousand times as much data as an ISDN line. However, the multiplexing technology used in the CXB1451Q and CXB1452Q can squeeze that data into a thin 1-mm cable. So, where's the technology that can do the same for my expanding waistline?



*New
Products*

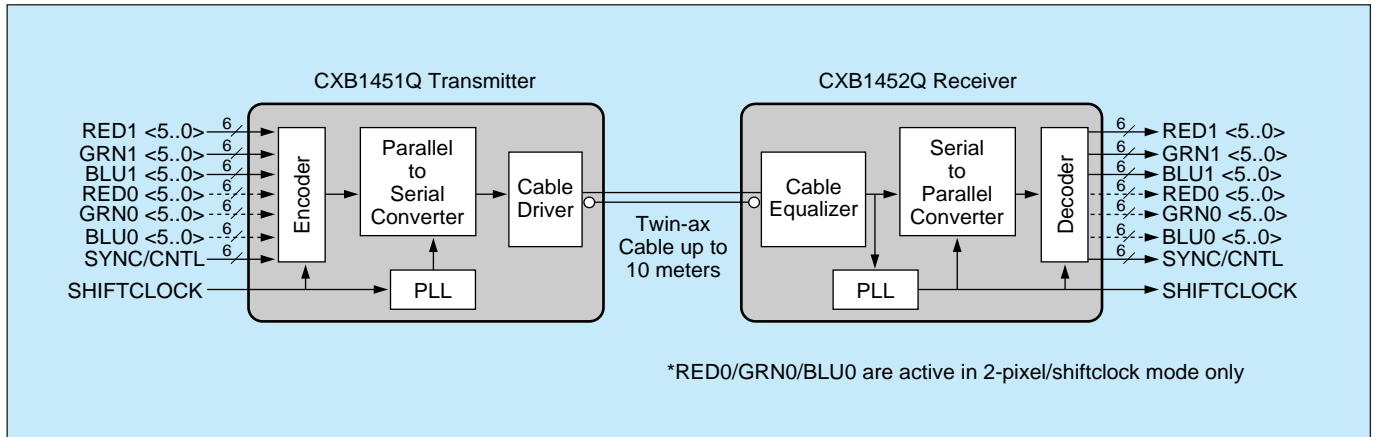

■ Figure 1 Block Diagrams of the CXB1451Q and CXB1452Q

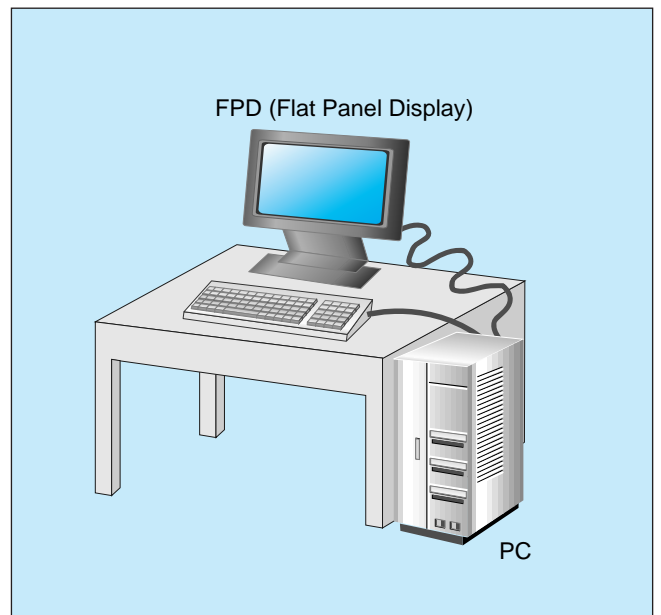

■ Figure 2 CXB1451Q and CXB1452Q Application Example

■ Table 1 CXB1451Q and CXB1452Q Display Modes

Panel Mode select

Panel 1	Panel 0	Supporting panel size & color
0	0	VGA (640×480) 18-bit color
0	1	SVGA (800×600) 18-bit color
1	0	XGA (1024×768) 18-bit color
1	1	SXGA (1280×1024) 9-bit color

Clock Mode select

CKMODE	Supporting clock mode
0	2-pixel/ShiftClock
1	1-pixel/ShiftClock

Operation Mode

Panel Mode	Clock Mode	Color	Shift clock	Dot clock	Serial rate
VGA	1-pixel/SftClk	18 bits	25 MHz	25 MHz	600 Mbps
	2-pixel/SftClk	18 bits	12.5 MHz	25 MHz	600 Mbps
SVGA	1-pixel/SftClk	18 bits	40 MHz	40 MHz	960 Mbps
	2-pixel/SftClk	18 bits	20 MHz	40 MHz	960 Mbps
XGA	1-pixel/SftClk	18 bits	65 MHz	65 MHz	1560 Mbps
	2-pixel/SftClk	18 bits	32.5 MHz	65 MHz	1560 Mbps
SXGA	1-pixel/SftClk	Not supported			
	2-pixel/SftClk	9 bits	56 MHz	112 MHz	1344 Mbps